

ASSTT. ENGINEER (PIA) IWMP P.S. PHALODI

**DETAILED PROJECT REPORT**  
**OF**  
**JODHPUR-XXXV (IWMP)**

(UNDER INTEGRATED WATERSHED MANAGEMENT PROGRAMME)

BLOCK: PHALODI

DISTRICT : JODHPUR

AGRO CLIMATIC ZONE- 1A

TOTAL GEOGRAPHICAL AREA – 6290 Hac.

TOTAL EFFECTIVE AREA- 5000 Hac.

TOTAL COST- 820.15 Lacs.

COST FROM PROJECT FUND- 750.00Lacs

COST FROM CONVERGENCE FUND- 70.15Lacs



SUBMITTED BY

ASTT. ENGINEER, WDSC

PANCHAYAT SAMITI -PHALODI

JODHPUR, (RAJASTHAN )

## Index

S.No	Topics	Page no.
------	--------	----------

### **1 Chapter**

- Location
- General Features of watershed (Cost and Area details)
- Climatic and Hydrological information
- Other Development Schemes in the project area
- Details of infrastructure in the project areas
- Institutional arrangements (,DWDU,PIA,WDT,WC)

### **2 Chapter Basic Data ,Analysis and Scope**

- 2.1 Demography Details
- 2.2 Development Indicators
- 2.3 Land use
- 2.4 Agriculture status and Productivity Gap Analysis
- 2.5 Horticulture/Vegetable/Floriculture status
- 2.6 Land holding pattern
- 2.7 Livestock status
- 2.8 Fodder status
- 2.9 Farm Implements
- 2.10 NREGS Status
- 2.11 Migration details
- 2.12 Livelihood Details.
- 2.13 Existing SHG
- 2.14 Ground Water details
- 2.15 Drinking Water Status
- 2.16 Water use efficiency
- 2.17 Slope details
- 2.18 Water Budgeting
- 2.19 Soil Details
- 2.20 Soil erosion status

### **3 Chapter Proposed Development Plan**

- 3.1 Consolidated
- 3.2 Project fund
- 3.3 Convergence Plan

## ***4 Chapter Activity wise Total Abstract of cost***

## ***5 Chapter Annual Action Plan***

5.1 Consolidated

5.2 Project fund

5.3 Convergence Plan

## ***6 Chapter Project outcomes***

## ***7 Technical designs and estimates for proposed activities***

## ***8 Enclosures***

### **8.1 Maps**

- a. Location –District, block, village, watershed location map
- b. Map of Project with Watershed Boundary demarcation in cadastral map
- c. Land Use Land Cover map
- d. Existing water bodies, DLT
- e. GIS based intervention map

### **8.2 Documents of Agreements:**

- Proceedings of gram sabha for DPR approval
- Proceedings of Panchayat Samiti General body for DPR approval
- DPR approval by district.
- Watershed Committee Registration certificate

# INTRODUCTION

## CHAPTER - I INTRODUCTION

### Location.

**Shri Krishan Nagar ( Jodhpur-35 ):** Project is located in Phalodi Block of JODHPUR district. The project area is between the latitudes 27 03'36" TO 27 11'59"N & longitudes 72 55'23" TO 73 01'58" E . It is at a distance 65 km from its Block head quarters and 140 kms from the district head quqters. there are 2 habitations in the Project area and other details are given below.

### General features of watershed

S. No.	Name of Project (as per GOI)	Shri Krishan Nagar ( Jodhpur - 35)
(a)	Name of catchment	Shri Krishan Nagar
(b)	Name of watershed area (Local name )	Shri Krishan Nagar
( c )	Project Area	6290 Hact.
(d)	Net Treatable Area	5000 Hact.
(e)	Cost of Project	75000000
(f)	Cost / Hectare	15000
(g)	Year of Sanction	2010-11
(h)	Watershed Code	Desert
(i)	No. of Gram Panchayat in Project Area	1
(j)	No. of villages in Project Area	2
(k)	Type of Project	Desert
(l)	Elevation ( metres )	–
(m)	Major streams	–
(n)	Slope range ( % )	1 to 4 %

Macro/ micro	Name of Gram Panchyat	Name of Villages Covered	Census code of villages	Area (Hact.)
	Shri Krisan Nagar	Shri Krishan Nagar	1924800	4500
		Ram Nagar	1924700	500

The watershed falls in Agroclimatic Zone **IA** . The Soil texture is **Sandy to lomy sandy soil**. The average rainfall is **200** mm. The temperatures in the area are in the range between 43.4 centigrade during summer and 26.3 centigrade during winter. The major Crops in the **area are Bajara, Wheat,Moong, Moth, mustared ground nut, Gowar, Jeera,Lahsun, Oil sheed,Custor**. 60% land is under Cultivation, 32% land fallow, 3% land is wasteland, 5% land is irrigated through Deep tube well of 36 No. of Household are small and marginal farmers ( 16.36% household ). Average land holding in the area is 207.55 hact. 45% area is single cropped area and 15 % is double cropped . The main soures of irrigation is Deep tube well. The average annual rainfall ( 5 years ) in the area is 200 mm. The Major festivals in the village are Holy, Deepawali,Id & Rakshabandhan.At present this village is having 07 population with Communities like Jat, Rajpoot, Meghwal, Muslim.Kumahar,Suthar,Bheel

### Climatic and Hydrological information

1	Average Annual Rainfall ( mm )	
S.No.	Year	Average Annual Rainfall (mm)
1	2002	58
2	2003	223
3	2004	79
4	2005	111
5	2006	205.5
6	2007	210
7	2008	270
8	2009	145
9	2010	420
10	2011	293
2	Average Monthly Rainfall ( mm )	
	Month	Rainfall (mm)
i	June	35.42
ii	July	101.22
iii	August	92.22
iv	Septamber	29.39

<b>3</b>	<b>Maximum rainfall intensity (mm )</b>			
	<b>Duration</b>		<b>Rainfall (mm)</b>	
<b>i</b>	15 minute duration		63	
<b>ii</b>	30 minute duration		52	
<b>iii</b>	60 minute duration		48	
<b>4</b>	<b>Temperature (Degree C)</b>			
	<b>Season</b>		<b>Max.</b>	<b>Min.</b>
<b>i</b>	Summer Season		43.4	26.4
<b>ii</b>	Winter Season		26.3	9.6
<b>iii</b>	Rainy Season		35.5	15.5
<b>5</b>	<b>Potential Evaporation Transpiration (PET) (mm/day)</b>			
	<b>Season</b>		<b>PET</b>	
<b>i</b>	Summer Season		15	
<b>ii</b>	Winter Season		3.8	
<b>iii</b>	Rainy Season		8.8	
		Total PET	27.6	
<b>6</b>				
	Time of return of maximum flood	5 year	10 years	In- Year
	Periodicity of Drought in village area	3 time in 5 year	7 time in 10 year	Alternate year

## Other Development Schemes in the Project area

S.No.	Scheme	Name of the deptment	Key interventions under the Scheme	Targeted Beneficiaries	Provisions under the Scheme
1	IAY	Rural development	Avas	BPL	Construction of Avas
2	CMGY	Rural development	Avas	BPL	Construction of Avas
2	MGNREGA	Rural development	Providing employment	All section	Basic Infrastructure Development
3	SFC	Rural development	Providing employment	Village Level	Community work
4	TFC	Rural development	Providing employment	Village Level	Community work
5	SGSY	Rural development	Lively Hood	BPL	Providing Loan

## Details of infrastructure in the Project areas

Parameters		Status			
i	No. of villages connected to the main road by an all weather road	Shri Krishan Nagar , Ramnagar			
ii	No. of villages provided with electricity	2			
iii	No. of households without access to drinking water	Nil			
iv	No. of educational institutions :	P	S	HS	VI
	Primary(P)/Secondary(S),HigherSecondary(HS)/vocational institution (V/I)	11	2	Nil	Nil
v	No. of villages with access to Primary Health Centre	Nil			
vi	No. of villages with access to Veterinary Dispensary	Nil			
vii	No. of villages with access to Post office	Nil			
viii	No. of villages with access to Banks	Nil			
ix	No. of villages with access to Markets/Mandis	Nil			

<b>x</b>	No. of villages with access to Agro-industries	Nil			
<b>xi</b>	Total quantity of surplus milk	Nil			
<b>xii</b>	No. of milk collection centres	U	S	PA	O
	(e.g. Union(U)/Society(S)/Private agency(PA)/Others(O))	Nil	Nil	Nil	Nil
<b>xiii</b>	No. of villages with access to Anganwadi Centre	2			
<b>xiv</b>	Any other facilities with no. of village (please specify)	-			
<b>xv</b>	Nearest KVK	Jodhpur (Mandore)			
<b>xvi</b>	Cooperative society	Shri Krishan Nagar			
<b>xvii</b>	NGOs	Nil			
<b>xviii</b>	Credit institutions	Nil			
	(i) Bank	Nil			
	(ii) Cooperative Society	Shri Krishan Nagar			
<b>xix</b>	Agro Service Centre's	Phalodi			

#### **Institutional arrangements (SLNA,DWDU,PIA,WDT,WC,Secretary)**

##### **DWDU Detail**

1	2	3
<b>S.No.</b>	<b>Particulars</b>	<b>Details of DWDU</b>
1	PM ,DWDU	Ex. En. Watershed Jodhpur
2	Address with contact No. website	Near RTO office, Jodhpur 0291-2544171
3	Telephone	0291-2544171
4	Fax	0291-2570746
5	E-mail	pm.dwdu.jodhpur@gmail.com

##### **SLNA Detail**

1	2	3
<b>S.No.</b>	<b>Particulars</b>	<b>Details of SLNA</b>
1	Member Secretary	Post-CEO
2	Designation and Address	Director Watershed development and soil Coservation
3	Telephone	0141-2227858
4	Fax	0141-2227189
5	E-mail	dir_wdsc@dataone.in

**PIA Particulars**

1	2	3
S.No.	Particulars	Details of P.I.A.
1	Name of PIA	Hanuman Ram Choudhary (A.En.)
2	Designation	A. En.
3	Address with Contact No. website	P. S. Phalodi (Jodhpur)
4	Telephone	9414319334
5	Fax	
6	E-mail	<a href="mailto:iwmp.phalodi@gmail.com">iwmp.phalodi@gmail.com</a>

**WDT Particulars**

1	2	3	4	5	6	7	8
S.No.	Name of WDT member	M/F	Age	Quqlificati on	Experience in watershed( Yrs)	Descripti on of professio nal training	Role/Fu nction
1	Vikram Singh	M	28	B.E.Electric al	1	Engineerin g work	Engg. Work
2	Pradeep	M	24	Diploma in veterinary	1	Veterinary work	Veter. Work
3	Rameshwari Bishnoi	F	28	B.A.B.Ed.	1	Social Scientist	Social work
4	Ram kumar	M	27	M.Sc.(agri)	1	Agriculture Scientist	Agricultu e work

Scheme :- IWMP

Panchayat Samiti Phalodi

Watershed :- Shri Krishan Nagar (Jodhpur - 35)

District : Jodhpur

**Details of Watershed Committees (WC ) Shri Krishan Nagar**

S. No.	Name of WC's	Date of Gram Sabha for WCD	Date of Registration as a Society (dd/mm/yyyy)	Designation	Name	M/F	Name of UG/SHG	Sc/ST/OB C/General	Landless/ MF/SF/BF	Educational qualification	Khasra No.
1	Shri Krishan Nagar Jodhpur-35	04.02.2011	N.A.	President	GOPARAM S/O NAWLARAM	M	UG	OBC	LF	X <sup>th</sup>	
2				Secretary	RINKI W/O PRAVEEN KUMAR	M	UG	OBC	LF	M.A.	
3				Member	ADU RAM S/O NATHA RAM	M	UG	OBC	SF	X <sup>th</sup>	
4				Member	KISNA RAM S/O BHERA RAM	M	UG	SC	MF	LITERATE	
5				Member	KISNA RAM S/O RAMLAL	M	SHG	OBC	MF	VIII <sup>th</sup>	
6				Member	BAGDU RAM S/O RATNA RAM	M	UG/SHG	OBC	MF	VI <sup>th</sup>	
7				Member	MEHRDIN S/O ALUKHAN	M	UG/SHG	OBC	MF	V <sup>th</sup>	
8				Member	GHAMANDA RAM S/OMANGNA RAM	M	UG/SHG	GEN	Land Less	LITERATE	
9				Member	BHOMA RAM S/O CHUNA RAM	M	UG	SC	LF	V <sup>th</sup>	
10				Member	ASHALATA W/O MANGI LAL	F	SHG	OBC	LF	LITERATE	
11				Member	MADU W/O NAGA RAM	F	UG/SHG	OBC	MF	LITERATE	
12				Member	MULA RAM S/O GAJA RAM	M	UG	OBC	MF	LITERATE	
13				Member	BHANWAR SINGH S/O VISHAN SINGH	M	UG	OBC	LF	LITERATE	
14				Member	HANUMAN RAM CHOUDHARY	M	Departmental Engg.			B.E.	

## **Problems and scope of improvement in the project area**

The socio economic conditions of the area can be improved through increased production which can be achieved through expansion in cultivated area and productivity enhancement 150 hact. Land is arable wasteland and 1600 hact. is fallow can be brought under cultivation. 88.99 hact. is only irrigated and with efforts this can be increased to 500 .The productivity gap of major crops in the area as compared with district and with areas in the same agro climatic zones indicate potential to increase the productivity. The demonstration of improved package of practices, improved varieties, increased irrigation facilities and soil conservation measures under the project can bridge this gap. Due to small land holdings in the area focus of the project would be on diversification in agriculture (horticulture, vegetables, green houses, Agro forestry, fodder crops) and diversification in Livelihoods (Agriculture, Animal husbandry, self employment) 38300 Quantal fodder scarcity can be met out through Pasture development. Improved animal Husbandry practices can increase the productivity of livestock. 45 no. of persons migrate due to Lack of Employment this migration can be checked through creation of employment opportunities in the project area through increase in production and diversification in agriculture and Livelihoods as mentioned above.

# **CHEPTER-II**

**Sosio economic**

**FEATURE,**

**PROBLEMS AND**

**SCOPE**

**CHEPTER-II**

**Sosio economic Features, Problems and Scope**

**Table 2.1 Population & Household Details :**

Total Population				
Male	Female	Total	SC	ST
2397	2112	4509	534	53

Household Details						
BPL household	Land less	Small Farmer	Marginal Farmer	Total household	SC household	ST household
308	8	165	89	635	82	8

**Table 2.2 Development indicators**

S.No.	Development Indicators	State	Project Area
1	Per capita income (Rs.)	16260	8550
2	Poverty Ratio	0.22	0.33
3	Literacy (%)	60.40%	40%
4	Sex Ratio	921	899
5	Infant mortality Ratio		63/1000
6	Maternal mortality Ratio		4/1000

**Table indicates poor socio economic conditions**

**Table 2.3 Land Use**

Land Use	Total area in Hact.				
	Private	Panchayat	Government	Community	Total
Agriculture Land	4550	—	—	—	4550
Temporary follow	450	—	—	—	450
permanent follow	210	—	—	—	210
Cultivated Rainfed	4367	—	—	—	4367
Cultivated Irrigated	183	—	—	—	183
Net Sown area	4550	—	—	—	4550
Net area sown more than once	183	—	—	—	183
Forest Land	0	—	—	—	0
Waste Land	15	15	—	—	15
Pastures Land	435	—	435	—	435
Others	0	—	—	—	—
Total		—	—	—	5000

The project area has 15 Hact. Of cultivable wasteland 660 Hact. Of fallow land (Total 675 Hact.) can be brought under cultivation if some irrigation source can be provided through Construction of WHS like Khadin, Tanka, Farm pond etc. and also through demnstration of rainfed varieties of crops. Construction of WHS can also increase in area under irrigation which is only 183 Hact. ( 4 %). 150 Hact. ( 1 %) is under wasteland s and can be brought under vegetative filter strip, V-ditches, staggered trenches, WHS (Johad) Afforestation of wastelands and Pasture development will be taken up on these land.

Pasture development the land use table shows that there is 450. Hectare pasture land ( 9 %) This emphasizes the need for taking up pastureland development works through sowing of promising species of grasses and plantation

**Table 2.4.a Agriculture and horticulture status and fuel availability.**

Cropping Status												
S.No.	Season	Crop sown	Reinfed				Irrigated				Total	
			Varieties	Area (Hact)	Production (Tone)	Productivity (qt./ha.)	Varieties	Area (Hact)	Production (Tone)	Productivity (qt./ha)	Area (Hact)	Production (Tone)
1	Kharif	Bajara	WCC75 RSB2 RJ 171	2295	1377	6		0	0	0	2295	1377
		Moong	K851 RMG 62 SML 668 G-8	45	9	2		0	0	0	45	9
		Moth	RMO 40 RMO435	735	220.5	3		0	0	0	735	220.5
		Till	RT 127 RT 125 RT 46	4	0.8	2		0	0	0	4	0.8
		Gowar	RGC 936 RGC 986 RGC1003 HG 563 M 83	965	289.5	3		3	0.9	3	968	290.4
		Mongphali	M 13 GG 20 GG 10 M 335	67	26.8	4		100	40	4	167	66.8
		Caster	GCH 4 RHC 8 Jayoti Mayco 6	0	0	0		49	24.5	5	49	24.5

		Chilly	NP 46A Mathania Long Jawar 218	0	0	0		0	0	0	0	0
		Gajar	Pusa Kesar Nentis Pusa Mandakani(S-5)	0	0	0		0	0	0	0	0
2	Rabi	Wheat	LOC 1 RJ 3077 HD 2329 RJ 1282	0	0	0	LOC 1 RJ 3077 HD 2329 RJ 1282	0	0	18	5.6	10.08
		Mustered	Bio 902 RH 819 RN 505 T.59 (Varuna)	0	0	0	Bio 902 RH 819 RN 505 T.59 (Varuna)	0	0	12	40.1	48.12
		Jeera	RS-1 RZ-19 RZ-209	0	0	0	RS-1 RZ-19 RZ-209	31		4	31	124
		Lahsoon	Ymuna White G-1,2 (G-50) Gujrat	0	0	0	Ymuna White G-1,2 (G-50) Gujrat	0	0	0	0	0
3	Zaid	Rayda		251	75.3	3		0	0	0	251	75.3
		Taramira		5	1	2		0	0	0	5	1
				0	0	0		0	0	0	0	0
	Total			<b>4367</b>	<b>2000</b>			<b>183</b>	<b>65.4</b>		<b>4550</b>	<b>2065.3</b>

Table 2.4.b Abstract of cropped Area ( hact.)	
Area under Single crop	4367
Area under Double crop	183
Area under Multiple crop	Nil

**\*\*Write for each crops :** The farmers are using **WCC 75. RJ 171** varieties of Bajra, where as varieties like **MH169, RHB 121** can increase the production.

**Crop Rotation \*\*** will vary from project to project

Fallow	–	Moth
Bajra	–	Jeera
Gawar	–	Lahsun
Fallow	–	Caster
Fallow	–	Groundnut
Ground nut	–	Wheet
Fallow	–	Moong
Cluster Bean	–	Fallow
Fallow	–	Tarameera
Till	–	Fallow
Caster	–	Caster
Moth	–	Fallow

The table 2.3 shows that only 250 hect. is ( 5 %) is double cropped area. Also the crop rotation shows that fallow lands are there. This indicates that there is scope for change in crop rotation in fields where there are fallow lands through Soil and Water conservation measures, crop demonstration and diversification in agriculture.

Soil and Water conservation measures besides putting fallow lands under cultivation can change the area under single cropping to double and multiple cropping.

**Table 2.4.c Productivity Gap Analysis (The table can also be given in bar chart form)**

S.No.	Name of the crop	India	Highest Average in Rajasthan	District	Project Area
1	Bajra	802	655	750	620
2	Moong	317	159	320	295
3	Moth	144	122	270	315
4	Weath	2619	2762	2150	0
5	Till	310	149	270	240
6	Gawar	510	525	515	450

Analysis of the above table indicate that besides national gap there is wide gap in productivity with in state and even with in same agro climatic zones.

The reasons for this variation are :-

- 1 The farmers are using vaing varieties WCC 75 of Bajara R1 171 whereas the recommended varities like **MH169, RHB 121** provided 7 qt./hact. Yield(write for all crops)
- 2 Lack of Availibility of good quality seeds of desired crop and variety in adequate quantities and time to the farmers.
- 3 Availability of water for cultivation ( 5 % is irrigated)

The productivity gap and reasons of indicate potential to increase the productivity through crop demonstration. Crop demonstrations would be carried out on improved crop/varieties, improved agronomic practices. INM,IPM, 'Mixed cropping, distribution of fodder seed mini kit.' Demonstration of improved methods and economics of fodder crops cultivation and also distribution foundation seeds of Forage Crops for further multiplication, introduction of fodder crops in the existing crop rotations

**Table 2.5 Existing area under horticulture/Vegitables/Floriculture(hact.)**

Activity	Area	Species	Varieties	Recommened varieties	Production
Horticulture	–	–	–	–	–
	–	–	–	–	–
	–	–	–	–	–
Vegitable	–	–	–	–	–
	–	–	–	–	–
	–	–	–	–	–
Floriculture	–	–	–	–	–
	–	–	–	–	–
	–	–	–	–	–
Medicinal Plants	–	–	–	–	–

**Table 2.6 Land holding Pattern in project area**

S.No	Type of Farmer	Total House Holds	Land holding(hact.) irrigation source wise			Land holding (hact.) Social group wise				
			Irrigated(source)	Rainfed	Total	General	SC	ST	OBC	BPL
i	Large farmer	184	125	1372	1497	288	176	–	561	0
ii	Small farmer	279	35	1625	1660	379	111	–	738	85
iii	Marginal farmer	164	18	834	852	379	633	–	535	423
iv	Landless person	8	0	0	0	0	0	0	0	0
v	No. of BPL house hold	192	5	536	541	32	633	–	85	33
vi	Total	635	183	4367	4550	1078	1553	–	1919	541

2512 hact. Land holding belong to small and marginal farmers who own 55% of total cultivated area 4550 Hact. Horticulture/vegetables could be more economical to small & marginal farmers with irrigation source. For large farmers with no irrigation facility Horticulture/vegetables will be promoted in a part of land with farm pond / Tanka construction.

The following activities will be more beneficial for small land holdings and for diversification and income for large farmers.

#### **Horticulture plantation, Medicinal and Aromatic Crops, floriculture:-**

As discussed earlier Horticulture/ vegetables could be more economical to Small and marginal farmers with irrigation source. Also the project area has good potential for medicinal & aromatic crops like Sonamukhi, Issabgol, Ashwagandha, Khus, Mehandi etc.

#### **Agro forestry plantation:-**

To increase the income of farmers and also for shelter belt plantation as wind velocity is high in the project area.

#### **Setting of vermi Compost Units :-**

Keeping in view the side effect of residues of chemicals and fertilizers on human health the emphasis would be on cultivation of organic produce through motivating farmers and providing

assistance for production of organic input, vermi compost.

### **Production and distribution of quality seed:-**

There is need to ensure that good quality seed is available for cultivators for which adequate seed production would be initiated in watershed areas with the assistance of private sector and agriculture department technologies.

### **Sprinklers and pipelines :-**

For efficient water management practices emphasis on demonstration of sprinklers with adequate financial support and convergence/ private partnership.

### **Establishment of Green House :-**

For growing off season vegetables seedlings and other horticultural crops under controlled atmospheric conditions of green house.

### **Establishment of nurseries :-**

Most of the planting material is procured from other parts of the State/ Contry. The procurement of planting material from distant places causes damage to the planting material and often results in untimely supply. Hence nursery development activity in area.

### **Innovative hi - tech/ export oriented activities :-**

Innovative hi - tech/ export oriented projects like mushroom cultivation, floriculture, etc which are in negligible existence at present, can be implemented by individual farmers / private companies. Storage structure like Onion storage ,fodder storage and grain storage can be constructed.

### **Drip irrigation:-**

Drip irrigation will be promoted in all horticulture plantations, vegetables, green houses and in nurseries for rational use of irrigation higher yields and quality produce.

**Table 2.7 Livestock Status- animals / milk producton / average yield.**

S.No.	Description of animal	Population in No.	Yield (Milk/Mutton/Wool)	Equ. Cow unit	Dry matter requirement per year (7 kg/animal)	Total requirement in M.T.
1	Cows	1284	5136 lit/day	4 lit/day	8988 kg	8.98 Tone
	Indigenous	1284	5136 lit/day	4 lit/day	8988 kg	8.98 Tone
	Hybrid	0	0	—	0	0
2	Buffaloes	185	1110 lit/day	6 lit/day	1470 kg	1.5 Tone
3	Goat	3665	3665 lit/day	Population/2	9125 kg	9.12Tone
4	Sheep	1234	wool 16192 lb/year	16 lb/ year	3085 kg	3.08 Tone
5	Camel	10	—	—	70 kg	0.07 Tone
6	Poultry	0	—	NA	—	—
7	Piggery	0	—	NA	—	—
	TOTAL	7662		—	—	22.75

In spite of large number of livestock, production is less hence increase in productivity across all species, is a major challenge. To reduce production of unproductive cattle and improve the productivity by improving the breeds by breeding management following activities will be taken up.

- Castration - Bardigo Castration
- Artificial insemination - HF Tharparkar
- Distribution of superior Breeding bulls for use in cattle and Buffalo
- Breeding distribution crossbred rams (Chokala,Marwari)

Cattle-Tharparkar,Gir,Ratthi
------------------------------

Buffalo-Murrah,
-----------------

Besides breed improvement other animal husbandry practices like better health, hygiene and feeding practices can increase productivity of livestock. Hence Activities like Animal health camps, Urea - Molasses treatment demonstration, demonstration of improved methods of conservation and utilization of Forage crops are proposed.

**Table 2.8 Existing area under fodder (hact.)**

S.No.	Item	Unit	Area/Quantity
1	Existing Cultivable area under Fodder	Hact.	1600
2	Production of Green fodder	Tone/year	–
3	Production of Dry fodder	Tone/year	4800
4	Area under Pastures	Hact.	–
5	Production of fodder	Tone/year	–
6	Existing area under Fuel wood	Hact.	NIL
7	Supplementary feed	Kgs / day	–
8	Silage Pits	No.	–
9	Availability of fodder	Tones	4800
10	Deficiency / excess of fodder	Tones	3383.3 Tone

The table above shows there is fodder deficiency ( Requirement is 8303.75 tone and availability 4800 tones )

To minimize the large and expanding gap between feed and fodder resource availability and demand there is need for :-

- Increase in area under fodder crops

- Increase in productivity of fodder crops
- Development of pastures
- And reduction in large number of livestock production through replacement by few but productive animals.

**Table 2.9 Agriculture Implements :-**

1	2	3
S.No.	Implements	Nos.
1	Tractor	70
2	Sprayers-manual / power	40
3	Cultivators / Harrows	70
4	Seed drill	40
5	Any other trolley	70

**Table 2.10 NREGA Status - No. of job card Holder, activities taken so far, employment status. :-**

S.No.	Name of village	Total No. of Job card	Employment Status	Activity taken up so far
1	Shri Krishan Nagar	743	335	Road & Nadi
2	Shri Ram Nagar	457	185	

**Table 2.11 Migration Details :-**

Name of village	No. of persons migrating	No. of days per year of migration	Major reason(s) for migrating	Distance of destination of migration from the village (km)	Occupation during migration	Income from such occupation (Rs. In lakh)
Shri Krishan Nagar	55	8 to 10 month	Driver/Salsman/Mason	450	Driver/Salsman/Mason	29.00
Shri Ram Nagar	23	9 to 10 month	Driver/Salsman/Mason	452	Driver/Salsman/Mason	8.00

The migration can be check by creation of employment opportunities,enhancing farm level economy, increases the income of the people engaged in animal husbandry by dairy, poultry and marketing and value addition,( As discussed earlier ) and diversification in livelihoods.

**The existing livelihoods Village are given below :-**

Table 2.12 (a) Major activities (On Farm)		
Name of activity	No. of House holds	Average annual income from the / Lacs

Cultivators	627	195.5
Dairying	–	–
Poultry	–	–
Piggery	–	–
Landless Agri. Labourers	8	1.45

**Table 2.12 (b) Major activities (Off Farm)**

Name of activity	No. of House holds/individuals	Average annual income from the / Lacs
Artisans	5	0.3
Carpenter	7	4.20
Black smith	3	1.80
Leather Craft	10	3.60
Porter	30	9.50
Mason	100	36.00
Others specify(Cycle Repair, STD, Craft etc)	60	8.00

The efforts for increase in income through off farm activities will be made under livelihood component through assistance to SHG or individuals.

**Table 2.13 (a) Status of Existing SHG :-**

S.No.	No. of SHG	Members	Activity involved	Monthly income	Fund available	Assistance available	Source of assistance	Training received
1	7	70	–	3500		–	–	2

The table indicates existence of number of groups in the area also these need to be strengthened through trainings and financial assistance.

## II. Technical Features

**Table 2.14 Ground Water :-**

S.No.	Source	No.	Functionall depth	Dry	Area irrigated	Water availability(days)
i	Dug wells	1	Nil	–	Nil	–
ii	Shallow tube wells	Nil	Nil	–	–	–

iii	Pumping sets	Nil	Nil	-	-	-
iv	Deep tube wells	36	400'	-	183hact	12 Month
	Total	36				

**Table 2.15 Availability of drinking water :-**

S.No.	Name of the village	Drinking water requirement Lts/day	Present availability of drinking ltrs/day	No. of drinking water sources available	No. functional	No. requires repairs	No. defunct ional
1	Krishan Nagar	70000 lits	40000 lits	2 T.W.	2	-	-
2	Ramnagar	20000 lits	10000 lits	1 T.W.	1	-	-

**Table 2.16 Water use efficiency :-**

Name of Major Crop	Area ( Hectare )		
	Through water saving devices (Sprinklers)	Through water conserving agronomic practices	Any other (pl specify)
Wheat	6.6/kg/ha/mm	2.5	-
Maize	5.5/kg/ha/mm	2.5	-
Vegitable	22.22/kg/ha/mm	10	-

- The table above indicate need for judicious use of available Water.
- Encouraging optimum use of water through installation of sprinklers on every operational wells.

**Table 2.17 Slope details :-**

Slope of Watershed		
S. No.	Slope percentage	Area in hectares
1	0 to 3 %	5000

As most of the area has slope less than 3% construction of contour bunds can solve the problem of water erosion in agriculture fields and protect washing of top soil and manures/fertilisers.

**Table 2.18 Water Budgeting :-**

**Table 2.18(a) Total available runoff (cum) use Stranges table :-**

Area	Type of Catchment	Yield of runoff from catchment per hect. (cum.) use Stranges table	Total Runoff(cum.)
	Average	42.64	213200

	Total		213200
--	-------	--	--------

**Table 2.18(b) Details of already stored runoff (Surface Water structures :-**

S.No.	Name	No.	Storage Capacity (cum )	Area irrigated (hect.)
i	Major irrigation Project	Nil	–	–
ii	Medium irrigation Project	Nil	–	–
iii	Farm Pond / Tanks (Nadi)	8	33036	–
iv	Anicuts	Nil	–	–
	Total	Nil	–	–

**Table 2.18(c) Details of Proposed Structure for Surface Water Storage :-**

S.No.	Name	No.	Storage Capacity (cum )	Area irrigated (hect.)
i	Major irrigation Project	Nil	–	–
ii	Medium irrigation Project	Nil	–	–
iii	Farm Pond / Tanks	330	6600	–
iv	Anicuts	Nil	–	–
	Total		6600	

**Table 2.18(d) Balance available runoff (cum) :-**

Total runoff (cum)	213200
Net tapped Runoff (cum)	39636
Balnce Runoff (cum)	173564
Percentage of water stored w.r.t. runoff	18.59

The water budgeting indicates potential for water harvesting in the area.

**The need is :-**

- To check land degradation
- To reduce excessive biotic pressure by containing the number and increase of livestock
- To check cultivation on sloping lands without adequate precautions of soil and water conservation measures
- To discourage cultivation along susceptible nallah beds
- To check faulty agriculture techniques

- To check uncontrolled grazing and developed cattle tracks
- To check Deforestation of steep slopes
- To check erosive velocity of Runoff, store Runoff, to arrest silt carried by runoff and to recharge Ground Water structures life, Earthen check dams, Gully plugs, Bank stabilisation, Loose stone check dams, Gabions, Earthen embankment (Nadi) and Anicuts would be taken up.

**Table 2. 19 Soil details**

<b>A</b>	<b>Soil Profile</b>	
S.No.	Major Soil Classes	Area in hectares
1	Sandy to loamy sand soils	5000
2		
<b>B</b>	<b>Soil Depth</b>	
	Depth (Cms)	Area in hectares
1	0.00 to 7.50	5000
2	7.5 to 45.00	5000
3	>45.00	5000

<b>C</b>	Soil fertility Status	Kg/hect.	Recommended
	N	0.52 to 0.22	–
	P	2.7 to 15.55	–
	K	16.00 to 28.00	–
	Micronutrients	PPM	–
	Iron	4.8 to 9.5	–
	MN	63.8 to 13.5	–
	CU	0.85 to 1.9	–
	Zn	0.8 to 2.2	–

The analysis of table shows need to improve and maintain soil fertility. Soil health card to every farmer every crop season will be provided, which will include the recommendation for Application micro nutrient and fertilizers.

**Table 2.20 Erosion details :-**

<b>Erosion status in Project Area</b>				
<b>Cause</b>	<b>Type of erosion</b>	<b>Area affected (hect.)</b>	<b>Runoff (mm/year)</b>	<b>Average soil loss (Tonnes/hect/year)</b>
Water erosion				
a	Sheet	4550	250	3 to 7
b	Rill	450	250	3 to 5
c	Gully			
Sub Total				
Wind erosion		100		4 to 8
Total for Project				3 to 8

**CHAPTER = III Proposed Development Plan:** The Activities are indicative addition/deletion in activities will be as per local conditions.

**(A) Preparatory phase activities Capacity Building Trainings and EPA**

The IEC activities like Kalajathas, Groupmeetings, door to door compaogn, slogans, and wall writings etc. were carried out in all the habitations of Shri Krishan Nagar watershed. A series of meetings were conducted with GP members, community and discussed about the implementation of IWMP programme. User groups were also formed.

Gram Sabhas were conducted for approval of EPA (Village), for selecting the watershed committee and approval of DPR.

S.No.	Name of the Gram Panchayat	Date of which Gram Shabha approved EPA
1	Shri Krishan Nagar	25.03.2011

S.No.	Name of Village	Amount earmarked for EPA	Entry Point Activities planned	Estimated cost in lac.	Expenditure incurred	Balance	Expected outcome	Actual outcome
1	2	3	4	5	6	7	8	9
1	krishannagar		1.Instalation of Solar light DGSC item No. 29	7.50	7.35	0.15		Villagers are very happy
			2.Drinking water activities	22.50	22.5	0.00		
2	Ramnagar		-	-	-	-	-	
	Total w/s		-	30.00	29.85	0.15		

S.No.	Name of the village/ Habitation	Date on which PRA conducted
1	Sh. Krishan Nagar	05 -10-2011 to 20-10-2011
2	Ram Nagar	21 -11-2011 to 30-10-2011

The PRA exercise was carried out in all the villages on the dates shown below:

Transaot walk were carried out involving the community for Social mapping, Resource mapping, Detailed discussions and deliberations with all the primary stakeholders were carried out.

Socio-economic survey was carried out during 25 -03- 2011 to 31- 07-2011 period covering all the households and primary data on demography, Land holdings, Employmeng status, Community activities etc. was collected as mentioned in chapter 2.

State remote sensing department was assigned the work of preparing various thematic layers using Cartosat-1 and LISS-3 imageries for Creation, development and management of geo-spatial database depicting present conditions of land (terrain), water and vegetation with respect to watershed under different ownerships at village level.

Various thematic layers provided by SRSAC are:-

- Delineation of Macro/Micro watershed boundaries
- Digitised Khasra maps of the villages falling in project area
- Network of Drainage lines, existing water bodies, falling in the project area.
- Base maps ( transport network, villade / boundaries, and settlements)
- Land Use/Land cover map.
- Contours at 1 metre interval, slope map.

Based on GIS thematic layers, Field visits, PRA and analysis of benchmark data (as discussed in chapter 2) final Treatment plan on revenue map for implementation has been framed. Thus each intervention identified has been marked on revenue map (map enclosed in DPR as annexure..8.2). The GIS based intervention map, PRA based intervention map are annexed as..8.1.

**PROPOSED**

**DEVELOPMENTAL**

**PLAN**

## CHAPTER III

### CONSOLIDATED DEVELOPMENT PLAN (PROJECT & OTHER SCHEME)

<b>STATE : RAJASTHAN</b>	<b>GEOGRAPHICAL AREA: 6290 Hact.</b>
<b>DISTRICT: JODHPUR</b>	<b>EFFECTIVE AREA : 5000 Hact.</b>
<b>NAME OF THE BLOCK: PHALODI</b>	<b>(i) ARABLE LAND 4550</b>
<b>NAME OF WATERSHED: Jodhpur -35 (IWMP)</b>	<b>(ii) NON ARABLE LAND: 450 Hact.</b>
<b>CATEGORY OF WATERSHED: Desert Area</b>	<b>COST FROM IWMP PROJECT: 750 lac</b> <span style="float: right;">750</span>
	<b>COST FROM CONVERGENCE:</b> <span style="float: right;">70.15</span>
	<b>Consolidated</b> <span style="float: right;">820.15</span>

Total Cost in Lakh:

820.15

S.No.	Activity	Unit	Total Target		GP-Sh. Krishan Nagar	
			Phy.	Fin.	Phy.	Fin.
<b>A I</b>	Administration cost	10%		75.00		75.00
II	Monitoring	1%		7.50		7.50
III	Evaluation	1%		7.50		7.50
IV	Preparatory Phase (Entry Point Activity)	4%		30.00		30.00
V	Institution and Capacity Building	5%		37.50		37.50
VI	Preparation of Detailed Project Report (DPR)	1%		7.50		7.50
	<b>Total</b>	22%		165.00		165.00
<b>B</b>	<b>Watershed Development Works (NRM)</b>	56%				
<b>I</b>	<b><u>Arable Land Conservation Measures</u></b>					
1	Earthen Bund	Hact	714	78.50	714	78.50
2	Gully Control Structure (L.S.C.D.)	No.	24	2.40	24	2.40
3	Water Harvesting Tanka	No.	330	329.55	330	329.55
4	Wasteweir	No.	20	10.00	20	10.00
5	Percolation tank / Recharging well		12	12.00	12	12.00
6	Diggi /Hauge		8	4.00	8	4.00
	<b>Total</b>			12.00		436.45
<b>II</b>	<b><u>Non Arable Land Conservation Measures</u></b>					
1	Ditch Cum Bund /Barbed wire Fencing	Mt	4500	55.55	4500	13.85
2	Contour Furrow in Pasture Land	Hact	100	13.85	100	12.25
3	Contour Furrow in Non Arable Land	Hact	100	12.25	100	0.00
4	Earthen Bund	No.	150	0.00	150	17.25
5	Tanka	No.	8	20.25	8	8.00
	<b>Total</b>			39.10		51.35
	<b>Total Watershed Development Works</b>			487.80		487.80
<b>C</b>	<b>Production System</b>	10%				
<b>I</b>	<b>Arable Land Production System</b>					
1	Crop/Fooder Demonstration	No.	300	15.00		15.00
2	Agro Forestry	No.	16000	3.00		3.00
3	Dry land Horticulture and Medicinal plant	No.	44	13.00		13.00
4	Homestead Kitchen Garden	No.	300	3.00		3.00
5	Organic Farming					
	i Compost Pit	No.	200	4.00		4.00
	ii Vermi Compost Unit	No.	20	2.00		2.00

	<b>Total</b>			40.00		40.00
<b>II</b>	<b>Non Arable Land Production System</b>					
1	Plantation in Pasture land and along DLT.	No.	9275	10.85	9275	10.85
2	Over seeding in Pasture Land	Hact	100	2.35	100	2.35
3	Over seeding in Non Arable Land	Hact		0.00		2.35
	<b>Total</b>			15.55		15.55
<b>III</b>	<b>Live Stock Management</b>					
1	Animal Health Camps	No.	20	4.80	20	4.80
2	Mangers Distribution	No.	500	5.00	500	5.00
3	Cattlecare and Fodder storage centre	No.	2	10.00	2	10.00
4	Bull Distribution	No.	4	2.00	4	2.00
	<b>Total</b>			21.80		21.80
	<b>Total Production System</b>			75.00		75.00
<b>D</b>	<b>Livelyhood</b>	9%		0.00		0.00
<b>1</b>	<b>Revolving fund to SHG (&gt;60% of 9%)</b>	No.	163	40.75		40.75
<b>2</b>	<b>Revolving fund to Enterperising Individual(10% of 9%)</b>	No.	27	6.75	27.00	6.75
<b>3</b>	<b>Grant in aid to federation of SHG (30% of 9%)</b>	No.	10	20.00	10.00	20.00
	<b>Total</b>			67.50		67.50
<b>E</b>	<b>Consolidation</b>	3%		22.50		22.50
	<b>Grand Total</b>			820.15		820.15

## CHAPTER III

### PROPOSED DEVELOPMENT PLAN THROUGH PROJECT FUND

STATE : RAJASTHAN

UNIT COST: Rs. 15000/- Per Hact.

DISTRICT: JODHPUR

GEOGRAPHICAL AREA: 6290 Hact.

NAME OF THE BLOCK: PHALODI

EFFECTIVE AREA : 5000 Hact.

NAME OF WATERSHED: Jodhpur -35 (IWMP)

(i) ARABLE LAND : 4550 Hact.

CATEGORY OF WATERSHED: Desert Area

(ii) NON ARABLE LAND : 450 Hact.

COST FROM IWMP PROJECT: 750.00

Total Cost in Lakh: **750.00**

Lakh

S.No.	Activitiy	Unit	Total Target		GP-Shri Krishan Naga		
			Phy.	Fin.	Phy.	Fin.	
<b>A</b>	<b>I</b>	Administration cost	10%		75.00		75.00
	II	Monitoring	1%		7.50		7.50
	III	Evaluation	1%		7.50		7.50
	IV	Preparatory Phase (Entry Point Activity)	4%		30.00		30.00
	V	Institution and Capacity Building	5%		37.50		37.50
	VI	Preparation of Detailed Project Report (DPR)	1%		7.50		7.50
		<b>Total</b>	<b>22%</b>		<b>165.00</b>		<b>165.00</b>
<b>B</b>		<b>Watershed Development Works (NRM)</b>	<b>56%</b>				
	<b>I</b>	<b>Arable Land Conservation Measures</b>					
	1	Earthen Bund	No.	514	56.50	565	56.50
	2	Gully Control Structure	No.	24	2.40	24	2.40
	3	Water Harvesting Tanka	No.	300	300.00	300	300.00
	4	Wasteweir	No.	20	10.00	20	10.00
	5	Percolation tank / Recharging well	No.	12	12.00	12	12.00
	6	Diggi /Hauje					
		<b>Total</b>			<b>380.90</b>		<b>380.90</b>
	<b>II</b>	<b>Non Arable Land Conservation Measures</b>					
	1	Ditch Cum Bund /Barbed wire Fencing	Mt	4500	13.85	4500	13.85
	2	Contour Furrow in Pasture Land	Hact	100	12.25	100	12.25
	3	Contour Furrow in Non Arable Land	Hact				
	4	E.C.D.	No.	50	5.00	50	5.00
	5	Tanka	No.	8	8.00	8	8.00
		<b>Total</b>			<b>39.10</b>		<b>39.10</b>
		<b>Total Watershed Development Works</b>			<b>420.0</b>		<b>420.0</b>
<b>C</b>		<b>Production System</b>	<b>10%</b>				
	<b>I</b>	<b>Arable Land Production System</b>					
	1	Crop/Fooder Demonstration	No.	300	15.00	300	15.00
	2	Agro Forestry	No.	16000	3.00	16000	3.00
	3	Dry land Horticulture and Medicinal plant	No.	44	13.00		13.00
	4	Homestead Kitchen Garden/Manger/Grain storage bin	No.	300	3.00	300	3.00
	5	Organic Farming					
		i Compost Pit	No.	200	4.00	200	4.00
		ii Vermi Compost Unit	No.	20	2.00	20	2.00

	<b>Total</b>			<b>40.00</b>		<b>40.00</b>
<b>II</b>	<b>Non Arable Land Production System</b>					
1	Plantation in Pasture land and along DLT.	No.	9275	10.85	9275	10.85
2	Over seeding in Pasture Land	Hact	100	2.35	100	2.35
3	Over seeding in Non Arable Land	Hact				
	<b>Total</b>			<b>13.20</b>		<b>13.20</b>
<b>III</b>	<b>Live Stock Management</b>					
1	Animal Health Camps	No.	20	4.80	20	4.80
2	Mangers Distribution	No.	500	5.00	500	5.00
3	Cattlecare and Fodder storage centre	No.	2	10.00	2	10.00
4	Bull Distribution	No.	4	2.00	4	2.00
	<b>Total</b>			<b>21.80</b>		<b>21.80</b>
	<b>Total Production System</b>			<b>75.00</b>		<b>75.00</b>
<b>D</b>	<b>Livelyhood</b>	9%				
<b>1</b>	<b>Revolving fund to SHG (&gt;60% of 9%)</b>	No.	163	40.75		40.75
<b>2</b>	<b>Revolving fund to Enterperising Individual(10% of 9%)</b>	No.	27	6.75	27.00	6.75
<b>3</b>	<b>Grant in aid to federation of SHG (30% of 9%)</b>	No.	10	20.00	10.00	20.00
	<b>Total</b>			<b>67.50</b>		<b>67.50</b>
<b>E</b>	<b>Consolidation</b>	3%		<b>22.50</b>		<b>22.50</b>
	<b>Grand Total</b>			<b>750.00</b>		<b>750.00</b>

## CHAPTER III

### PROPOSED DEVELOPMENT PLAN THROUGH CONVERGENCE

STATE : RAJASTHAN

DISTRICT: JODHPUR

NAME OF THE BLOCK: PHALODI

NAME OF WATERSHED: Jodhpur -35 (IWMP)

CATEGORY OF WATERSHED: Desert Area

GEOGRAPHICAL AREA: 6290 Hact.

EFFECTIVE AREA : 5000 Hact.

(i) ARABLE LAND : 4550Hact.

(ii) NON ARABLE LAND : 450Hact.

COST FROM CONVERGENCE: 70.15

Lakh

S.No.	Activity	Unit	Total Target		GP-Shri Krishan Naga		
			Phy.	Fin.	Phy.	Fin.	
<b>A</b>	<b>I</b>						
	I	Administration cost	10%	-	0	0	
	II	Monitoring	1%	-	0	0	
	III	Evaluation	1%	-	0	0	
	IV	Preparatory Phase (Entry Point Activity)	4%	-	0	0	
	V	Institution and Capacity Building	5%	-	0	0	
	VI	Preparation of Detailed Project Report (DPR)	1%	-	0	0	
		<b>Total</b>	<b>22%</b>	<b>-</b>	<b>0</b>	<b>0</b>	
<b>B</b>		<b>Watershed Development Works (NRM)</b>	<b>56%</b>				
	<b>I</b>	<b>Arable Land Conservation Measures</b>					
	1	Earthen Bund	Hact	200	22.00	200	22.00
	2	Gully Control Structure (Loose. Stone. Check. Dam.)	No.				
	3	Water Harvesting Tanka	No.	30	29.55	30	29.55
	4	Wasteweir	No.				
	5	Percolation tank / Recharging well					
	6	Diggi/ Hauje	No.	8	4.00	8	4.00
		<b>Total</b>			<b>55.55</b>		<b>55.55</b>
	<b>II</b>	<b>Non Arable Land Conservation Measures</b>					
	1	Ditch Cum Bund /Barbed wire Fencing	Mt				
	2	Contour Furrow in Pasture Land	Hact				
	3	Contour Furrow in Non Arable Land	Hact	100	12.25	100	12.25
	4	Earthen Bund	No.				
	5	Tanka					
		<b>Total</b>			<b>12.25</b>		<b>12.25</b>
		<b>Total Watershed Development Works</b>			<b>67.80</b>		<b>67.80</b>
<b>C</b>		<b>Production System</b>	<b>10%</b>				
	<b>I</b>	<b>Arable Land Production System</b>					
	1	Crop/Fooder Demonstration					
	2	Agro Forestry	No.				
	3	Dry land Horticulture and medicinal plant	No.				
	4	Homestead Kitchen Garden	No.				
	5	Organic Farming					
		i Compost Pit	No.				
		ii Vermi Compost Unit	No.				
		<b>Total</b>					

<b>II</b>	<b>Non Arable Land Production System</b>					
1	Plantation in Pasture land and along DLT.	No.				
2	Over seeding in Pasture Land	Hact				
3	Over seeding in Non Arable Land	Hact	100	2.35	100	2.35
	<b>Total</b>			2.35		2.35
<b>III</b>	<b>Live Stock Management</b>					
1	Fodder Demonstration	No.				
2	Mangers Distribution	No.				
3	Animal Health Camps	No.				
4	Bull distribution					
	<b>Total</b>					
	<b>Total Production System</b>					
<b>D</b>	<b>Livelyhood</b>	9%				
<b>1</b>	<b>Revolving fund to SHG (&gt;60% of 9%)</b>	No.				
<b>2</b>	<b>Revolving fund to Enterprising Individual(10% of 9%)</b>	No.				
<b>3</b>	<b>Grant in aid to federation of SHG (30% of 9%)</b>	No.				
	<b>Total</b>					
<b>E</b>	<b>Consolidation</b>					
	<b>Grand Total</b>			70.15		70.15

# ABSTRACT OF COST

**CHAPTER IV**  
**ACTIVITY WISE TOTAL ABSTRACT COST**

STATE : RAJASTHAN

DISTRICT: JODHPUR

NAME OF THE BLOCK: PHALODI

NAME OF WATERSHED: Jodhpur -35 (IWMP)

CATEGORY OF WATERSHED: Desert Area

GEOGRAPHICAL AREA: 6290 Hact.

EFFECTIVE AREA : 5000 Hact.

(i) ARABLE LAND : 4550 Hact.

(ii) NON ARABLE LAND : 450 Hact.

COST FROM IWMP PROJECT : 750.00 Lacs

COST FROM CONVERGENCE : Total Cost :

S.No.	Activitiy	Unit	Quantity	Unit Cost	Total Cost	Cost from Project	Cost from Convergence	Beneficiary contribution*
A I	Administration cost	10%			75.00	75.00		
II	Monitoring	1%			7.50	7.50		
III	Evaluation	1%			7.50	7.50		
IV	Preparatory Phase (Entry Point Activity)	4%			30.00	30.00		
V	Institution and Capacity Building	5%			37.50	37.50		
VI	Preparation of Detailed Project Report (DPR)	1%			7.50	7.50		
	<b>Total</b>	<b>22%</b>			<b>165.00</b>	<b>165.00</b>		
<b>B</b>	<b>Watershed Development Works (NRM)</b>	<b>56%</b>						
<b>I</b>	<b><u>Arable Land Conservation Measures</u></b>							
1	Earthen Bund	No.	714		78.50	56.50	22.00	
2	Gully Control Structure (Loose. Stone. Check. Dam.)	No.	24		2.40	2.40		
3	Water Harvesting Tanka	No.	330		329.55	300.00	29.55	
4	Wasteweir	No.	20	50000/nos.	10.00	10.00		
5	Percolation tank / Recharging well	No.	12	1 lakh/nos.	25.00	12.00		
6	Diggi/Hauje	No.	10		4.00		4.00	
	<b>Total</b>				<b>436.45</b>	<b>380.90</b>	<b>55.55</b>	
<b>II</b>	<b><u>Non Arable Land Conservation Measures</u></b>							
1	Ditch Cum Bund / Barbed wire Fencing	Mts.	4500		13.85	13.85		
2	Contour Furrow in Pasture Land	Hact.	100	1225	12.25	12.25		
3	Contour Furrow in Non Arable Land	Hact.	100	1225	12.25		12.25	
4	E.C.D.	No.	50	1000	5.00	5.00		
5	Tanka	No.	8		8.00	8.00		
	<b>Total</b>				<b>51.35</b>	<b>39.10</b>	<b>12.25</b>	

	<b>Total Watershed Development Works</b>				487.80	420.00	67.80	
<b>C</b>	<b>Production System</b>	10%						
<b>I</b>	<b>Arable Land Production System</b>							
1	Crop/Fooder Demonstration	No.	300	5000	15.00	15.00		
2	Agro Forestry	No.	16000		3.00	3.00		
3	Dry land Horticulture & Medicinal plantation	No.	44	30000	13.00	13.00		
4	Homestead Kitchen Garden	No.	300	1000	3.00	3.00		
5	Organic Farming				0.00			
	i Compost Pit	No.	200	2000	4.00	4.00		
	ii Vermi Compost Unit	No.	20	10000	2.00	2.00		
	<b>Total</b>				40.00	40.00		
<b>II</b>	<b>Non Arable Land Production System</b>							
1	Plantation in Pasture land and along DLT line.	No.	9275		10.85	10.85		
2	Over seeding in Pasture Land	Hact.	100	2350/hac.	2.35	2.35		
3	Over seeding in Non Arable Land	Hact.	100	2350/hac.	2.35		2.35	
	<b>Total</b>				15.55	13.20	2.35	
<b>III</b>	<b>Live Stock Management</b>							
1	Animal Health Camps	No.	20	24000/camp	4.80	4.80		
2	Mangers Distribution	No.	250	2000/nos	5.00	5.00		
3	Cattlecare and fodder storage centre	No.	2	5lakh/nos	10.00	10.00		
4	Bull Distribution	No.	4	50000/nos.	2.00	2.00		
	<b>Total</b>				21.80	21.80		
	<b>Total Production System</b>				75.00	75.00		
<b>D</b>	<b>Livelyhood</b>				67.50	67.50		
<b>E</b>	<b>Consolidation</b>	3%			22.50	22.50		
	<b>Grand Total</b>				820.15	750.00	70.15	

\* Tentative and will vary during time of execution according to beneficiary

Rates will be taken prevailing at the time of execution of work

**PROPOSED**

**ANNUAL**

**ACTION PLAN**

## CHAPTER V

### ANNUAL ACTION PLAN CONSOLIDATED

STATE : RAJASTHAN

DISTRICT: JODHPUR

NAME OF THE BLOCK: PHALODI

NAME OF WATERSHED: Jodhpur -35 (IWMP)

CATEGORY OF WATERSHED: Desert Area

IRRIGATION PERCENTAGE : 10%

GEOGRAPHICAL AREA: 6040 Hact.

EFFECTIVE AREA : 5000 Hact.

(i) ARABLE LAND : 4550 Hact

(ii) NON ARABLE LAND : 450 Hact.

TOTAL

COST THROUGH CONSOLIDATE FUND :

S.No.	Activity	Unit	Quantity	Unit cost	Total cost	I <sup>st</sup> Year		II <sup>st</sup> Year		III <sup>st</sup> Year		IV <sup>st</sup> Year		V <sup>st</sup> Year		VI <sup>st</sup> Year		VII <sup>st</sup> Year		
						Phy.	Fin.	Phy.	Fin.	Phy.	Fin.	Phy.	Fin.	Phy.	Fin.	Phy.	Fin.	Phy.	Fin.	
<b>A</b>	<b>I</b>	Administration cost	10%		75.00		5.75		12.75		12.75		12.75		12.75		10.00		8.25	
	II	Monitoring	1%		7.50		0.25		0.50		0.75		1.00		2.00		2.00		1.00	
	III	Evaluation	1%		7.50		0.25		0.50		0.75		1.00		2.00		2.00		1.00	
	IV	Preparatory Phase (Entry Point Activity)	4%		30.00		5.00		25.00											
	V	Institution and Capacity Building	5%		37.50		5.00		20.00		12.50									
	VI	Preparation of Detailed Project Report (DPP)	1%		7.50		2.50		2.50		0.50		0.50		0.50		0.50		0.50	
		<b>Total</b>	<b>22%</b>		<b>165.00</b>		<b>18.75</b>		<b>61.25</b>		<b>27.25</b>		<b>15.25</b>		<b>17.25</b>		<b>14.5</b>		<b>10.75</b>	
<b>B</b>		<b>Watershed Development Works (NRM)</b>	<b>56%</b>																	
	<b>I</b>	<b>Arable Land Conservation Measures</b>																		
	1	Earthen Bund	No.	714	11000/ha	78.50		0.00		0.00	200	22.00	300	33.00	200	22.00	14	1.50	0	0.00
	2	Gully Control Structure (Loose. Stone. Check. Dam.)	No.	24	10000/no	2.40		0.00		0.00	10	1.00	10	1.00	4	0.40	0	0.00	0	0.00
	3	Water Harvesting Tanka	No.	330	1lac/nos	329.55		0.00		0.00	120	119.70	110	109.85	100	100.00	0	0.00	0	0.00
	4	Wasteweir	No.	20	50000/no	10.00		0.00		0.00	5	2.50	5	2.50	5	2.50	5	2.50	0	0.00
	5	Percolation tank/ Recharging well	No.	12	1 lakh/no	12.00					0	0.00	7	7.00	5	5.00	0	0.00	0	0.00
	6	Diggi/Hauje	No.	8	50000/no	4.00					4	2.00	4	2.00	0	0.00	0	0.00	0	0.00
		<b>Total</b>				<b>436.45</b>		<b>0.00</b>		<b>0.00</b>		<b>147.20</b>		<b>155.35</b>		<b>129.90</b>		<b>4.00</b>		<b>0.00</b>
	<b>II</b>	<b>Non Arable Land Conservation Measures</b>																		
	1	Ditch Cum Bund / Barbed wire Fencing	Mts.	4500		13.85		0.00		0.00	2500	7.67	2000	6.18		0.00		0.00		0.00
	2	Contour Furrow in Pasture Land	Hact.	100		12.25		0.00		0.00	50	6.25	50	6.00		0.00		0.00		0.00
	3	Contour Furrow in Non Arable Land	Hact.	100		12.25		0.00		0.00	50	6.25	50	6.00		0.00		0.00		0.00
	4	Earthen Bund	No.	50		5.00		0.00		0.00	20	2.00	30	3.00		0.00		0.00		0.00
	5	Tanka	No.	8		8.00		0.00		0.00				4	4.00	4	4.00	4	4.00	0.00
		<b>Total</b>				<b>51.35</b>		<b>0.00</b>		<b>0.00</b>		<b>22.17</b>		<b>21.18</b>		<b>4.00</b>		<b>4.00</b>		<b>0.00</b>
		<b>Total Watershed Development Works</b>				<b>487.80</b>		<b>0.00</b>		<b>0.00</b>		<b>169.37</b>		<b>176.53</b>		<b>133.90</b>		<b>8.00</b>		<b>0.00</b>

<b>C</b>	<b>Production System and Micro Enterprise</b>	19%																	
<b>I</b>	<b>Arable Land Production System</b>																		
1	Crop/Fooder Demonstration	No.	300	5000	15.00			0		300	15.00								
2	Agro Forestry	No.	1600		3.00			0		800	1.50	800	1.50						
3	Dry land Horticulture & medicinal plantation	No.	44	30000	13.00			12	3.50	12	3.50	15	4.50	5	1.50				
4	Homestead Kitchen Garden/Grain Storage bin	No.	300	1000	3.00			100	1.00	100	1.00	100	1.00						
5	Organic Farming																		
	i Compost Pit	No.	200	2000	4.00			50	1.00	50	1.00	50	1.00	50	1.00				
	ii Vermi Compost Unit	No.	20	10000	2.00			50	0.50	5	0.50	5	0.50	5	0.50				
	<b>Total</b>				40.00				6.00		22.50		8.50		3.00				
<b>II</b>	<b>Non Arable Land Production System</b>																		
1	Plantation in Pasture land and along DLT line.	No.	9275		10.85			7000	4.79	2275	3.56		1.00		0.75		0.75		
2	Over seeding in Pasture Land	Hact.	100		2.35			50	1.10	50	1.25								
3	Over seeding in Non Arable Land	Hact.	100		2.35			50	1.10	50	1.25								
	<b>Total</b>				15.55				6.99		6.06		1.00		0.75		0.75		
<b>III</b>	<b>Live Stock Management</b>																		
1	Animal Health Camps	No.	20	24000	4.80			4	0.96	4	0.96	4	0.96	4	0.96	4	0.96	4	0.96
2	Mangers Distribution	No.	250	2000	5.00			50	1.00	50	1.00	50	1.00	50	1.00	50	1.00	50	1.00
3	Cattle care and fodder storage center		2	500000	10.00					1	5.00	1	5.00						
4	Bull Distribution	No.	4	50000	2.00					2	1.00	2	1.00						
	<b>Total</b>				21.80				1.96		7.96		7.96		1.96		1.96		
	<b>Total Production System</b>				77.35				14.95		36.52		17.46		5.71		2.71		
<b>D</b>	<b>Livelihood</b>	9%																	
	<b>Revolving fund to SHG (&gt;60% of 9%)</b>	No.	163	25000/no	40.75			24	6.00	37	9.25	44	11.00	44	11.00	14	3.50		
	<b>Revolving fund to Enterprising Individual (10% of 9%)</b>	No.	27	25000/no	6.75			20	5.00	7	1.75	0	0.00	0	0.00				
	Grant in aid to federation of SHG (30% of 9%)	No.	10	2.00lakh/	20.00			2	4.00	2	4.00	2	4.00	2	4.00	2	4.00	2	4.00
	<b>Total</b>				67.5				15.00		15.00		15.00		15.00		7.50		
<b>E</b>	<b>Consolidation</b>	3%			22.5								7.50		7.50		7.50		
	<b>Grand Total</b>				820.15		18.75		61.25		226.57		243.30		191.11		50.71		28.46

## CHAPTER V

### ANNUAL ACTION PLAN THROUGH PROJECT FUND

STATE : RAJASTHAN

DISTRICT: JODHPUR

NAME OF THE BLOCK: PHALODI

NAME OF WATERSHED: Jodhpur -35 (IWMP)

CATEGORY OF WATERSHED: Desert Area

IRRIGATION PERCENTAGE : 10%

GEOGRAPHICAL AREA: 6290 Hact.

EFFECTIVE AREA : 5000 Hact.

(i) ARABLE LAND : 4550 Hact

(ii) NON ARABLE LAND : 450 Hact.

TOTAL

#### COST THROUGH PROJECT FUND :

S.No	Activity	Unit	Quantity	Unit cost	Total cost	I <sup>st</sup> Year		II <sup>st</sup> Year		III <sup>st</sup> Year		IV <sup>st</sup> Year		V <sup>st</sup> Year		VI <sup>st</sup> Year		VII <sup>st</sup> Year		
						Phy.	Fin.	Phy.	Fin.	Phy.	Fin.	Phy.	Fin.	Phy.	Fin.	Phy.	Fin.	Phy.	Fin.	
<b>A</b>	<b>I</b>																			
	Administration cost	10%			75.00		5.75		12.75		12.75		12.75		12.75		10.00		8.25	
	II Monitoring	1%			7.50		0.25		0.50		0.75		1.00		2.00		2.00		1.00	
	III Evaluation	1%			7.50		0.25		0.50		0.75		1.00		2.00		2.00		1.00	
	IV Preparatory Phase (Entry Point Activity)	4%			30.00		5.00		25.00											
	V Institution and Capacity Building	5%			37.50		5.00		20.00		12.50									
	VI Preparation of Detailed Project Report (DPR)	1%			7.50		2.50		2.50		0.50		0.50		0.50		0.50		0.50	
	<b>Total</b>	<b>22%</b>			<b>165.00</b>		<b>18.75</b>		<b>61.25</b>		<b>27.25</b>		<b>15.25</b>		<b>17.25</b>		<b>14.50</b>		<b>10.75</b>	
<b>B</b>	<b>Watershed Development Works (NRM)</b>	<b>56%</b>																		
	<b>I</b>																			
	<b>Arable Land Conservation Measures</b>																			
	1 Earthen Bund	No.	514	11000/ha	56.50		0.00		0.00	100	11.00	200	22.00	200	22.00	14	1.50		0.00	
	2 Gully Control Structure (Loose. Stone. Check. Dam.)	No.	24	10000/no	2.40		0.00		0.00	10	1.00	10	1.00	4	0.40				0.00	
	3 Water Harvesting Tanka	No.	300	1lac/nos	300.00		0.00		0.00	100	100.00	100	100.00	100	100.00				0.00	
	4 Wasteweir	No.	20	50000/no	10.00		0.00		0.00	5	2.50	5	2.50	5	2.50	5	2.50		0.00	
	5 Percolation tank /Recharging well	No.	12	1 lakh/nos	12.00							7	7.00	5	5.00					
	6 Diggi/Hauje	No.																		
	<b>Total</b>				<b>380.90</b>		<b>0.00</b>		<b>0.00</b>		<b>114.50</b>		<b>132.50</b>		<b>129.90</b>		<b>4.00</b>		<b>0.00</b>	
	<b>II</b>																			
	<b>Non Arable Land Conservation Measures</b>																			
	1 Ditch Cum Bund / Barbed wire Fencing	Mts.	4500		13.85		0.00		0.00	2500	7.67	2000	6.18		0.00		0.00		0.00	
	2 Contour Furrow in Pasture Land	Hact.	100		12.25		0.00		0.00	50	6.25	50	6.00		0.00		0.00		0.00	
	3 Contour Furrow in Non Arable Land	Hact.					0.00		0.00						0.00		0.00		0.00	
	4 Earthen Bund	No.	50		5.00		0.00		0.00	20	2.00	30	3.00		0.00		0.00		0.00	
	5 Tanka	No.	8		8.00		0.00		0.00					4	4.00	4	4.00		0.00	
	<b>Total</b>				<b>39.10</b>		<b>0.00</b>		<b>0.00</b>		<b>15.92</b>		<b>15.18</b>		<b>4.00</b>		<b>4.00</b>		<b>0.00</b>	
	<b>Total Watershed Development Works</b>				<b>420.00</b>		<b>0.00</b>		<b>0.00</b>		<b>130.42</b>		<b>147.68</b>		<b>133.90</b>		<b>8.00</b>		<b>0.00</b>	
<b>C</b>	<b>Production System</b>	<b>10%</b>																		
	<b>I</b>																			
	<b>Arable Land Production System</b>																			
	1 Crop/Fooder Demonstration	No.	300	5000	15.00					0		300	15.00							

2	Agro Forestry	No.	1600		3.00				0		800	1.50	800	1.50				
3	Dry land Horticulture & Medicinal plantation	No.	44	30000	13.00				12	3.50	12	3.50	15	4.50	5	1.50		
4	Homestead Kitchen Garden/Grain Storage bin	No.	300	1000	3.00				100	1.00	100	1.00	100	1.00				
5	Organic Farming																	
	i Compost Pit	No.	200	2000	4.00				50	1.00	50	1.00	50	1.00	50	1.00		
	ii Vermi Compost Unit	No.	20	10000	2.00				50	0.50	5	0.50	5	0.50	5	0.50		
	<b>Total</b>				40.00					6.00		22.50		8.50		3.00		
<b>II</b>	<b>Non Arable Land Production System</b>																	
1	Plantation in Pasture land and along DLT line.	No.	11200		10.85				7000	4.79	4200	3.56		1.00		0.75	0.75	
2	Over seeding in Pasture Land	Hact.	100		2.35				50	1.10	50	1.25						
3	Over seeding in Non Arable Land	Hact.																
	<b>Total</b>				13.20					5.89		4.81		1.00		0.75	0.75	
<b>III</b>	<b>Live Stock Management</b>																	
1	Animal Health Camps	No.	20	24000	4.80				4	0.96	4	0.96	4	0.96	4	0.96	4	0.96
2	Mangers Distribution	No.	250	2000	5.00				50	1.00	50	1.00	50	1.00	50	1.00	50	1.00
3	Cattle care and fodder storage center		2	500000	10.00						1	5.00	1	5.00				
4	Bull Distribution	No.	4	50000	2.00						2	1.00	2	1.00				
	<b>Total</b>				21.80					1.96		7.96		7.96		1.96	1.96	
	<b>Total Production System</b>				75.00					13.85		35.27		17.46		5.71	2.71	
<b>D</b>	<b>Livelihood</b>	9%																
	<b>Revolving fund to SHG (&gt;60% of 9%)</b>	No.	163	25000/no	40.75				24	6.00	37	9.25	44	11.00	44	11.00	14	3.50
	<b>Revolving fund to Enterprising Individual (10% of 9%)</b>	No.	27	25000/no	6.75				20	5.00	7	1.75	0	0.00	0	0.00		
	Grant in aid to federation of SHG (30% of 9%)	No.	10	2.00lakh/r	20.00				2	4.00	2	4.00	2	4.00	2	4.00	2	4.00
	<b>Total</b>				67.5					15.00		15.00		15.00		15.00	7.50	
<b>E</b>	<b>Consolidation</b>	3%			22.5									7.50		7.50	7.50	
	<b>Grand Total</b>				750.00		18.75		61.25		186.52		213.20		191.11		50.71	28.46



2	Agro Forestry	No.																
3	Dry land Horticulture (Unit)	No.																
4	Homestead Kitchen Garden/Grain Storage bin	No.																
5	Organic Farming																	
	i Compost Pit	No.																
	ii Vermi Compost Unit	No.																
	<b>Total</b>																	
<b>II</b>	<b>Non Arable Land Production System</b>																	
1	Plantation in Pasture land and along DLT line.	No.																
2	Over seeding in Pasture Land	Hact.																
3	Over seeding in Non Arable Land	Hact.	100	2.35			50	1.1	50	1.25								
	<b>Total</b>			2.35				1.1		1.25	0	0	0					
<b>III</b>	<b>Live Stock Management</b>																	
1	Animal Health Camps	No.																
2	Mangers Distribution	No.																
3	Cattle care and fodder storage center																	
4	Bull Distribution	No.																
	<b>Total</b>			0.00				0		0	0	0	0					
	<b>Total Production System</b>			2.35				1.1		1.25	0	0	0					
<b>D</b>	<b>Livelihood</b>	9%																
	<b>Revolving fund to SHG (&gt;60% of 9%)</b>	No.																
	<b>Revolving fund to Enterprising Individual (10% of 9%)</b>	No.																
	Grant in aid to federation of SHG (30% of 9%)	No.																
	Total																	
<b>E</b>	Consolidation	3%																
<b>D</b>	<b>Livelihood</b>	9%																
<b>E</b>	<b>Consolidation</b>	3%																
	<b>Grand Total</b>			70.15	0	0		40.05		30.10	0	0	0					

**Prosed Development Plan**

**CHAPTER – VI EXPECTED OUT COMES**

1	2	3	4	5	6
S. No.	Item	Unit of measurement	Pre-project Status	Expected Post-project Status	Remarks
1	Status of water table (Depth to Ground water level)	Meters	172	170	Due to Increase in Number of Deep Tube wells
2	Ground water structures repaired/ rejuvenated	No.	-		
3	Quality of drinking water	Description	Unsatisfactory	Satisfactory	
4	Availability of drinking water	Description	9 Month	12 month	
5	Change in irrigated Area	Ha	183	450	
6	Change in cropping/ land use pattern	Description	2020	1200	
7	Area under agricultural crop	Ha			
	I Area under single crop	Ha	4367	5450	
	li Area under double crop	Ha	183	450	
	lii Area under multiple crop	Ha	-	-	
8	Change in cultivated Area	Ha	-	-	
9	yield of major crops of area				
	Yield of Bajra	q/ha	6	8	
	Yield of Wheat	q/ha	18	21	
	Yield of Gram	q/ha	-	-	
	Yield of Mustard	q/ha	12	14	
10	production of major crops of area				
	Production of Bajra	ton	48.12	52.50	
	Production of Wheat	ton	10.08	15.20	
	Production of Gram	ton	-	-	
	Production of Mustard	ton	8.40	12.20	
11	Area under vegetation	Ha	-		
12	Area under horticulture	Ha	-		
13	Area under fuel	Ha	-		
14	Area under Fodder	Ha	-		
15	Fodder production	M.T.	4800	8250	
16	Milk production	Litres/day	2756	4350	
17	SHGs Active	No.	2	45	
18	No. of livelihoods	No.	-	-	
19	Income	Rs.in la	-	-	
20	Migration	No.	70	20	
21	SHG Federations formed	No.	Nil	5	

## **Critical Assumption**

- No severe droughts/ unexpected floods/ natural disasters
- Adequate funds are allocated for the same and released on time.
- There is no significant pest/ disease attack, and if so, then it will have been contained before irreversible damage is done.
- Adverse market conditions do not persist long.
- Sound macro-economic and growth conditions continue and the benefits are widely distributed particularly in the rural areas.
- Facilitating agencies and resource providers have the required competent staff so that timely and appropriate technical advice and services are provided to farmers whenever required.
- The Capacity Building Plan is implemented, monitored and modified to address evolving needs and feedback from participants.
- The execution of the Women's Empowerment Pedagogy is regularly monitored by the District and State level Implementing Agencies

## **Means of Verification of indicators**

- Baseline surveys like household income ,expenditure, health and nutrition etc at the beginning, mid-term and end of the project period
- Annual participatory assessment by communities during project period.
- Regular project monitoring reports prepared by project monitoring teams/ agencies.
- Membership and other Records, Minutes of Meetings maintained by the SHGs, WCs/ Individual beneficiaries/project-related village and local bodies/PRIs.
- External review missions
- Data maintained by Government department (Revenue, Agriculture, Groundwater, Irrigation, Animal Husbandry

## **CHAPTER VII TECHNICAL DESIGNS AND ESTIMATES**

Technical designs and estimates for proposed activities. Estimates are prepared on the basis of GKN of Jodhpur district.

## **CHAPTER - VIII Enclosures -**

8.1 a.Location –District, block, village, watershed location map

b.Map of Nevra Road IWMP Project (Watershed Boundary demarcation in cadastral & Topo Sheet)

c.PRA Map (along with photos & paper drawing)

d.Treatment map (Indicate proposed works)

e.Cadastral Map on watershed boundary

f.Land Use Land Cover map

g.Information on existing water harvesting structures & well inventory along with GPS co-ordinates.

h.High resolution, latest Remote Sensing Satellite data

### **8.2 Documents of Agreements:**

Proceedings of gram sabha for EPA approval

Proceedings of gram sabha Resolution for committee constitution

Proceedings of gram sabha for DPR approval

DPR approval by district

Watershed Committee Registration certificate.

## DESIGN OF BUND IN ARABLE LAND

1. V. I. =  $0.3\left(\frac{S}{3} + 2\right)$  - Ramser Formula

$$= 0.3\left(\frac{1}{3} + 2\right)$$

$$= 0.70 \text{ m.}$$

V. I. = Vertical interval between two consecutive bund (m.)

S = Land slop (%)

$$H. I. = \frac{V.I.}{S} \times 100$$

$$= \frac{0.70}{1} \times 100 = 70 \text{ m.} \quad (\text{H. I.} = \text{Horizontal Interval})$$

2. Depth of Impounding

$$h = \sqrt{\frac{R_{ex} \times V.I.}{50}}$$

h = Depth of impounding

Re = 24 hours rainfall excess (cm. ) for 10 years R. I.

= Rainfall – interception

$$H = \sqrt{\frac{20 \times 0.70}{50}}$$

$$= 0.52 \text{ cm.}$$

Say = 50 cm.

3. Height of Bund

$$H = h + \text{Free board}$$

$$= 0.50 + 0.25$$

$$= 0.75 \text{ CMS.}$$

4. Top width of Bund

$$= \frac{H}{2} = \frac{0.75}{2} = 0.375$$

Say= 0.40 cms

The side slopes of the bunds are dependent upon the internal fractional angle of the fill material. For light red loam and sandy loam soils, the side slope for the both the sides is taken 1.5:1

5. Cross section of the Bund:

$$\text{Cross section area of the bund} = \frac{\text{Top width} + \text{Bottom width}}{2} \times \text{height}$$

$$= \frac{0.40 + 2.65}{2} \times 0.75$$

$$= 1.14 \text{ sqm.}$$

## DESIGN OF WASTE WEIR

Calculation of peak rate of runoff

$$Q = \frac{CIA}{36} \quad (\text{Rational formula})$$
$$= \frac{0.3 \times 5 \times 23}{36} = 0.96 \text{ m}^3$$

$$Q = 1.71 Lh^{3/8}$$

or

$$L = \frac{Q}{1.71 h^{3/8}}$$

Where L = Length of crest in mt.

h = depth of flow over the crest in mt.

$$L = \frac{0.96}{1.71 \times 0.3^{3/8}} = 3.55 \text{ m}$$

**PLANTATION**  
**DETAILED ESTIMATE AND ABSTRACT OF COST**

**Name Of Work: Plantation Works in Non Arable land**

**(A) I<sup>st</sup> Year**

क्र.सं.	कार्य विवरण	प्रति	मात्रा	दर	राशि
1	45 x 45 x 45 सेमी माप के गड्डे करना कठोर मिट्टी कंकर/मुरम मिट्टी (बी.एस.आर. आइटम नं. 2 ब व स)	Nos.	300 200	6.80 13.40	2040.00 2680.00
2	पौधा रोपित करना (ब) सामान्य जमीन में पथरीली जमीन (बी.एस.आर. आइटम नं. 113 ब व स)	Nos.	300 200	3.60 3.00	1080.00 600.00
3	पौधों की निराई गुड़ाई करना 15 सेमी गहराई तक तथा 45 सेमी अर्द्धव्यास तक (बी.एस.आर. आइटम नं. 116)	Nos.	2x500= 1000	1.20	1200.00
4	पौधों को कीटनाशक देना मय कीटनाशक की कीमत (बाजार दर के अनुसार)	Nos.	500.00	2.00	1000.00
5	थांवला बनाना, कम से कम 50 सेमी अर्द्धव्यास का पथरीली जमीन अन्य जमीन (बी.एस.आर. आइटम नं. 117 अ व ब)	Nos.	200 300	2.40 1.80	480.00 540.00
6	पौधों को पानी पिलाना 15 लीटर प्रति पौधा (वर्ष में 12 बार) 500X6=3000 (बी.एस.आर. आइटम नं. 115)	Nos.	6000.00	1.80	10800.00
7	पौधे की लागत मय परिवहन (बाजार दर के अनुसार)	Nos.	500.00	20.00	10000.00
8	पौधों का परिवहन नर्सरी से वृक्षारोपण स्थल तक (लोडिंग व अनलोडिंग सहित) 1 कि.मी. ऊँट गाड़ी द्वारा	Nos.	500.00	1.00	500.00
9	पानी की लागत मय परिवहन 5 कि.मी. तक 15 ली X 3000 = 45000 ली. (बी.एस.आर. आइटम नं. 108)	Liter	45000.00	42.2/1000	1899.00
10	पाले व लू से बचाव हेतु झोंपे बनाना	Nos.	100.00	3.62	362.00
11	100 पौधों के पुर्निग करना (माडल एस्टीमेट वन विभाग)	Nos.	100.00	0.96	96.00
12	पौधों की देखभाल व सुरक्षा	Nos.	500.00	LS	5300.00

**TOTAL(A) 38557.00**

**DETAILED ESTIMATE AND ABSTRACT OF COST**

**Name Of Work: Plantation Works in Non Arable land**

**(B) II<sup>nd</sup> Year**

क्र.सं.	कार्य विवरण	प्रति	मात्रा	दर	राशि
1	100 पौधो का केजुयल्टी रिपलेसमेंट करना	Nos.	100.00	1.35	135.00
2	पौधे की लागत मय परिवहन (बाजार दर के अनुसार)	Nos.	100.00	20.00	2000.00
3	पौधो का परिवहन नर्सरी से वृक्षरोपण स्थल तक (लोडिंग व अनलोडिंग सहित)	Nos.	100.00	1.00	100.00
4	पौधों की निराई गुड़ाई करना 15 सेमी गहराई तक तथा 45 सेमी अर्द्धव्यास तक 2X500=1000 (बी.एस.आर. आइटम नं. 116)	Nos.	1000.00	1.20	1200.00
5	पौधों को पानी पिलाना 15 लीटर प्रति पौधा (वर्ष मे 6 बार) 500 X 3 =1500 (बी.एस.आर. आइटम नं. 115)	Nos.	3000.00	1.80	5400.00
6	पानी की लागत मय परिवहन 5 कि.मी. तक 15 ली X 1500 = 22500 yh- (बी.एस.आर. आइटम नं. 108)	Nos.	22500.0	37.4/100	841.50
7	100 पौधों के लिए पाले/लू से सुरक्षा हेतु झोंपे बनाना	Nos.	100.0	3.62	362.00
8	100 पौधों की पुर्निग करना	Nos.	100.0	0.96	96.00
9	पौधो की देखभाल व सुरक्षा	Nos.	500.0	LS	5300.00

**TOTAL(B) 15434.50**

**DETAILED ESTIMATE AND ABSTRACT OF COST**

**Name Of Work: Plantation Works in Non Arable land**

**(C) III<sup>rd</sup> Year**

क्र.सं.	कार्य विवरण	प्रति	मात्रा	दर	राशि
1	पौधों को पानी पिलाना 15 लीटर प्रति पौधा (वर्ष में 2 बार) 500 X 2 =1000 (बी.एस.आर. आइटम नं. 115)	Nos.	1000.00	1.90	1800.00
2	पानी की लागत मय परिवहन 5 कि.मी. तक 15 ली X 1000 = 15000 यh- (बी.एस.आर. आइटम नं. 108)	Nos.	15000.0	42.2/100	633.00
3	पौधों की निराई गुड़ाई करना 15 सेमी गहराई तक तथा 45 सेमी अर्द्धव्यास तक 1X500=1000 (बी.एस.आर. आइटम नं. 116)	Nos.	500.00	1.30	650.00
4	200 पौधों की पुर्निग करना	Nos.	200.0	0.96	192.00
5	पौधों की देखभाल व सुरक्षा	Nos.	500.0	LS	5300.00

**TOTAL(C) 8575.00**

Scheme: IWMP

Watershed: Sh. Krishan Nagar (Jodhpur-35)

Panchayat Samiti: PHALODI

District: Jodhpur

**DETAILED ESTIMATE AND ABSTRACT OF COST**

**Name Of Work: Plantation Works in Non Arable land**

**(D) IV<sup>th</sup> Year**

क्र.सं.	कार्य विवरण	प्रति	मात्रा	दर	राशि
1	पौधों की देखभाल व सुरक्षा	Nos.	500.0	LS	5300.00

**TOTAL(D) 5300.00**

**Total Cost Per Ha. (A+B+C)=38457+15434.5+8453+5300=56229.50**

	<b>67866.50</b>
Add 4% Contingency	2714.66
G. TOTAL	70581.16
<b>Say Rs.</b>	<b>70500.00</b>
	Per Ha.

(Rupees Forty Eight Thousand Five hundred only)

Labour	45500.00
Material	22290.00
Contigency	<u>2710.00</u>
Total	<u><b>70500.00</b></u>

Note: Rate has been taken from the BSR issued by Zila Parishad Jodhpur on 1/4/2012.

**W. D. T. (Technical)**  
**I. W. M. P.**  
**P. S. PHALODI**

**A. En. & P. I. A.**  
**I. W. M. P.**  
**P. S. Phalodi**

## लागत तकमीना

नाम जल ग्रहण क्षेत्र : श्री कृष्णनगर रामनगर

कार्य का नाम—चरागाह भूमि पर खाई फेंसिंग

गाँव का नाम : श्री कृष्णनगर

क्षेत्रफल: 35 हैक्टेयर

35.00

क्र.सं.	विवरण	मात्रा	इकाई	दर		राशि	
				श्रम	कुल	श्रम	कुल
1	डाग बेलिंग 2.5 से 5 सेमी गहराई तक (जि.स्त. दर.अनु.)	3530.00	मीटर	0.7	0.70	2471.00	2471.00
2	नीव, खाई परनाला में 1.5 गहराई तक मिट्टी का खुदाई करना, तल को कूटना, पानी डालना, बगल को संवारना, खुदी मिट्टीको बाहर निकालना, नीव भरने के बाद खाली स्थानों को पुनः मिट्टी से भरना तथा बची हुई मिट्टी को 50 मीटर दूरी तक निस्तारण करना। सख्त मिट्टी में। खाई हेतु	5083.20	घ.मी.	100	100.00	508320.00	508320.00
3	डिबलिंग विधि से वानिकी बीज बुवाई कार्य	10500.00	मीटर	0.6	0.60	6300.00	6300.00
4	वानिकी बीजों की राशि	50.00	कि.ग्रा	-	40.00		2000.00
5							
	<b>योग</b>					<b>517091.00</b>	<b>519091.00</b>
	<b>योग</b>						<b>519091.00</b>
	<b>जोडा 4: कन्टोजेन्सी</b>						<b>20763.64</b>
	<b>योग</b>						<b>539854.64</b>
	<b>लागत श्रम भाग</b>						<b>517091.00</b>
	<b>लागत सामग्री भाग</b>						<b>22763.64</b>
	<b>कुल योग</b>						<b>539854.64</b>

**Say 540000.00**

## लागत तकमीना

नाम जल ग्रहण क्षेत्र—श्री कृष्णनगर

कार्य का नाम— कृषि भूमि पर  
वेजीटेटिव कन्टूरबन्ड

1

80

क्र.सं.	विवरण	मात्रा	इकाई	दर		राशि	
				श्रम	कुल	श्रम	कुल
1	डाग बेलिंग 2.5 से 5 सेमी गहराई तक (जि.स्त. दर.अनु.2011)	160.00	मीटर	0.70	0.70	112.00	112.00
2	मिट्टी का कार्य बन्ध में (सूखी या गीली) 15 सेमी परत में डालना, ढेलों को तोडना, घास—पात तथा कंकर बीनकर अलग करना तथा मिट्टी की दरेसी करना 1.5 मी० उठाना तथा 50 मीटर दूरी के लिए। कठोर मिट्टी में मिट्टी की कुटाई मानव द्वारा या प्लेन रोलर द्वारा।(जि.स्त.दर.अनु.2011)	99.20	घ.मी.	100.00	100.00	9920.00	9920.00
3	धामन/घास बीज बुवाई बनाये गये रिज पर दो लाईनों में (जि.स्त.दर.अनु.2011)	240.00	मीटर	0.60	0.60	144.00	144.00
4	धामन घास बीज	1.00	कि.ग्रा	.	61.50		61.50
	<b>योग</b>					10176.00	10237.50
	<b>योग</b>						10237.50
	<b>जोडा 4: कन्टोजेन्सी</b>						409.50
	<b>योग</b>						10647.00
	<b>लागत श्रम भाग</b>						10176.00
	<b>लागत सामग्री भाग</b>						471.00
	<b>कुल योग</b>						10647.00
						Say	11000.00

## विस्तृत तकमीना

नाम जल ग्रहण क्षेत्र— जोधपुर-35 (I.W.M.P) कार्य का नाम—अकृषि भूमि पर कन्टूर फर्रो  
 गाँव का नाम : श्री कृष्णनगर क्षेत्रफल: 150 हैक्टर

क्र.सं.	विवरण	ल.गचौ.गग. त्र कुल मात्रा
1	ए फ्रेम लेवल से 8 से 15 मीटर क्षैतिज अन्तराल में समोच्च रेखा पर ले आउट का कार्य	150 हैक्टर / 800मी० / हैक्टेयर=120000 मी०
2	डाग बेलिंग 2.5 से 5 सेमी गहराई तक (जि.स्त.दर.अनु.2010पृ.सं० 25 क.सं. 182)	1,20,000 मी.
3	नीव, खाई परनाला में 1.5 गहराई तक मिट्टी का खुदाई करना, तल को कूटना, पानी डालना, बगल को संवारना, खुदी मिट्टीको बाहर निकालना, नीव भरने के बाद खाली स्थानों को पुनः मिट्टी से भरना तथा बची हुई मिट्टी को 50 मीटर दूरी तक निस्तारण करना। सखा, चिकनी, कंकर, मिट्टी में। नीव हेतु (जि.स्त.दर.अनु.2010पृ.सं० 5क.सं. 2ब)	1,20,000 मीx1/2x0.60x0.30=10800०
4	बीज बुवाई बनाये गये रिज पर	1,20,000 मी.
5	बीज की मात्रा (धामण)	1,20,000 मी. / 1 कि.ग्रा. / 100 मीटर=1200

## लागत तकमीना

नाम जल ग्रहण क्षेत्र—जोधपुर—35

कार्य का नाम—अकृषि भूमि पर कन्टूर फर्रो

गाँव का नाम : श्री कृष्णनगर

क्षेत्रफल: 150 हैक्टर

क्र.सं.	विवरण	मात्रा	इकाई	दर		राशि	
				श्रम	कुल	श्रम	कुल
1	ए फ़ेम लेवल से 8 से 15 मीटर क्षैतिज अन्तराल में समोच्च रेखा पर ले आउट का कार्य	120000	मी.	0.85	0.85	102000.00	102000.00
2	डाग बेलिंग 2.5 से 5 सेमी गहराई तक (जि.स्त.दर.अनु.2010पृ.सं0 25 क.सं. 182)	120000	मी.	0.35	0.35	42000.00	42000.00
3	नीव, खाई परनाला में 1.5 गहराई तक मिट्टी का खुदाई करना, तल को कूटना, पानी डालना, बगल को संवारना, खुदी मिट्टीको बाहर निकालना, नीव भरने के बाद खाली स्थानों को पुनः मिट्टी से भरना तथा बची हुई मिट्टी को 50 मीटर दूरी तक निस्तारण करना।सख्त,चिकनी, कंकर, मिट्टी में नीव हेतु(जि.स्त.दर.अनु.2010पृ.सं0 5 क.सं. 2ब)	10800	घ.मी.	61.00	61.00	658800.00	658800.00
4	बीज बुवाई बनाये गये रिज पर	120000	मी.	0.44	0.44	52800.00	52800.00
5	बीज की मात्रा (धामण)	1200	कि.ग्रा.	-	50.00	-	60000.00
	<b>योग</b>					<b>855600.00</b>	<b>915600.00</b>
	<b>जोडा श्रमिक दर में बढ़ोत्तरी 35:</b>						<b>299460.00</b>
	<b>योग</b>						<b>1215060.00</b>
	<b>जोडा 3: कन्टोजेन्सी</b>						<b>36451.80</b>
	<b>योग</b>						<b>1251511.80</b>
	<b>लागत श्रम भाग</b>						<b>1155060.00</b>
	<b>लागत सामग्री भाग</b>						<b>96451.80</b>
	<b>कुल योग</b>						<b>1251511.80</b>
						<b>Say</b>	<b>1251000.00</b>

## विस्तृत तकमीना

नाम जल ग्रहण क्षेत्र— जोधपुर—35  
गाँव का नाम : श्री कृष्णनगर

कार्य का नाम—अकृषि भूमि पर कन्टूर फर्रो  
क्षेत्रफल: 100 हैक्टर

क्र.सं.	विवरण	ल.गचौ.गग. त्र कुल मात्रा
1	ए फ्रेम लेवल से 8 से 15 मीटर क्षैतिज अन्तराल में समोच्च रेखा पर ले आउट का कार्य	100 हैक्टर / 800मी <sup>0</sup> / हैक्टेयर=80000 मी <sup>0</sup>
2	डाग बेलिंग 2.5 से 5 सेमी गहराई तक (जि.स्त.दर.अनु.2010पृ.सं0 25 क.सं. 182)	80000 मी.
3	नीव, खाई परनाला में 1.5 गहराई तक मिट्टी का खुदाई करना, तल को कूटना, पानी डालना, बगल को संवारना, खुदी मिट्टीको बाहर निकालना, नीव भरने के बाद खाली स्थानों को पुनः मिट्टी से भरना तथा बची हुई मिट्टी को 50 मीटर दूरी तक निस्तारण करना। सख्त, चिकनी, कंकर, मिट्टी में। नीव हेतु (जि.स्त.दर.अनु.2010पृ.सं0 5 क.सं. 2ब)	80000 मी <sup>0</sup> × 1/2 × 0.60 × 0.30 = 7200
4	बीज बुवाई बनाये गये रिज पर	8000 मी.
5	बीज की मात्रा (धामण)	8000 मी. / 1 कि.ग्रा. / 100 मीटर <sup>त्र</sup> 800

## लागत तकमीना

नाम जल ग्रहण क्षेत्र- जोधपुर-35  
गाँव का नाम : श्री कृष्णनगर

कार्य का नाम-अकृषि भूमि पर कन्टूर फर्रो  
क्षेत्रफल: 100 हैक्टर

क्र.सं.	विवरण	मात्रा	इकाई	दर		राशि	
				श्रम	कुल	श्रम	कुल
1	ए फ़ेम लेवल से 8 से 15 मीटर क्षैतिज अन्तराल में समोच्च रेखा पर ले आउट का कार्य	80000.00	मी.	0.85	0.85	68000.00	68000.00
2	डाग बेलिंग 2.5 से 5 सेमी गहराई तक (जि.स्त.दर.अनु.2010पृ.सं0 25 क्र.सं. 182)	80000.00	मी.	0.35	0.35	28000.00	28000.00
3	नीव, खाई परनाला में 1.5 गहराई तक मिट्टी का खुदाई करना, तल को कूटना, पानी डालना, बगल को संवारना, खुदी मिट्टीको बाहर निकालना, नीव भरने के बाद खाली स्थानों को पुनः मिट्टी से भरना तथा बची हुई मिट्टी को 50 मीटर दूरी तक निस्तारण करना। सख्त, चिकनी, कंकर, मिट्टी में। नीव हेतु (जि.स्त.दर.अनु.2010पृ.सं0 5 क्र.सं. 2ब)	7200.00	घ.मी.	61.00	61.00	439200.00	439200.00
4	बीज बुवाई बनाये गये रिज पर	80000.00	मी.	0.44	0.44	35200.00	35200.00
5	बीज की मात्रा (धामण)	800.00	कि.ग्रा.	-	50.00	-	40000.00
	<b>योग</b>					570400.00	610400.00
	<b>जोडा श्रमिक दर में बढ़ोत्तरी 35:</b>						199640.00
	<b>योग</b>						810040.00
	<b>जोडा 3: कन्टोजेन्सी</b>						24301.20
	<b>योग</b>						834341.20
	<b>लागत श्रम भाग</b>						770040.00
	<b>लागत सामग्री भाग</b>						64301.20
	<b>कुल योग</b>						834341.20
						Say	834000.00

## विस्तृत तकमीना

नाम जल ग्रहण क्षेत्र— जोधपुर—35  
गाँव का नाम :श्री कृष्णनगर

कार्य का नाम—अकृषि भूमि पर कन्टूर फर्रो  
क्षेत्रफल: 100 हैक्टर

क्र.सं.	विवरण	ल.गचौ.गग. त्र कुल मात्रा
1	ए फ्रेम लेवल से 8 से 15 मीटर क्षैतिज अन्तराल में समोच्च रेखा पर ले आउट का कार्य	100 हैक्टर / 800मी <sup>0</sup> / हैक्टेयर <sup>त्र</sup> 80000 मी <sup>0</sup>
2	डाग बेलिंग 2.5 से 5 सेमी गहराई तक (जि.स्त.दर.अनु.2010पृ.सं0 25 क.सं. 182)	80000 मी.
3	नीव, खाई परनाला में 1.5 गहराई तक मिट्टी का खुदाई करना, तल को कूटना, पानी डालना, बगल को संवारना, खुदी मिट्टीको बाहर निकालना, नीव भरने के बाद खाली स्थानों को पुनः मिट्टी से भरना तथा बची हुई मिट्टी को 50 मीटर दूरी तक निस्तारण करना। सख्त, चिकनी, कंकर, मिट्टी में। नीव हेतु (जि.स्त.दर.अनु.2010पृ.सं0 5 क.सं. 2ब)	80000 मी <sup>ग1ध2ग0प60ग0प30त्र7200</sup>
4	बीज बुवाई बनाये गये रिज पर	8000 मी.
5	बीज की मात्रा (धामण)	8000 मी. / 1 कि.ग्रा. / 100 मीटर <sup>त्र</sup> 800

## लागत तकमीना

नाम जल ग्रहण क्षेत्र— जोधपुर—35  
गाँव का नाम : श्री कृष्णनगर

कार्य का नाम—अकृषि भूमि पर कन्टूर फर्रो  
क्षेत्रफल: 100 हैक्टर

क्र.सं.	विवरण	मात्रा	इकाई	दर		राशि	
				श्रम	कुल	श्रम	कुल
1	ए फ़ेम लेवल से 8 से 15 मीटर क्षैतिज अन्तराल में समोच्च रेखा पर ले आउट का कार्य	80000.00	मी.	0.85	0.85	68000.00	68000.00
2	डाग बेलिंग 2.5 से 5 सेमी गहराई तक (जि.स्त.दर.अनु.2010पृ.सं0 25 क.सं. 182)	80000.00	मी.	0.35	0.35	28000.00	28000.00
3	नीव, खाई परनाला में 1.5 गहराई तक मिट्टी का खुदाई करना, तल को कूटना, पानी डालना, बगल को संवारना, खुदी मिट्टीको बाहर निकालना, नीव भरने के बाद खाली स्थानों को पुनः मिट्टी से भरना तथा बची हुई मिट्टी को 50 मीटर दूरी तक निस्तारण करना। सख्त, चिकनी, कंकर, मिट्टी में। नीव हेतु (जि.स्त.दर.अनु.01प05प2012)	7200.00	घ.मी.	100.00	100.00	720000.00	720000.00
4	बीज बुवाई बनाये गये रिज पर	80000.00	मी.	0.44	0.44	35200.00	35200.00
5	बीज की मात्रा (धामण)	800.00	कि.ग्रा.	-	50.00	-	40000.00
	<b>योग</b>					851200.00	891200.00
	<b>जोडा श्रमिक दर में बढ़ोत्तरी 35:</b>						297920.00
	<b>योग</b>						1189120.00
	<b>जोडा 4: कन्टोजेन्सी</b>						35673.60
	<b>योग</b>						1224793.60
	<b>लागत श्रम भाग</b>						1149120.00
	<b>लागत सामग्री भाग</b>						75673.60
	<b>कुल योग</b>						1224793.60
						<b>Say</b>	1225000.00

## लागत तकमीना

नाम जल ग्रहण क्षेत्र—श्री कृष्णनगर रामनगर

कार्य का नाम— कृषि भूमि पर  
वेजीटेटिव बन्ड

1.00      35.00

क्र.सं.	विवरण	मात्रा	इकाई	दर		राशि	
				श्रम	कुल	श्रम	कुल
1	डाग बेलिंग 2.5 से 5 सेमी गहराई तक (जि.स्त. दर.अनु.2010पृ.सं025 क्र.सं. 182)	70.00	मीटर	0.7	0.70	49.00	49.00
2	मिट्टी का कार्य बन्ध में (सूखी या गीली) 15 सेमी परत में डालना, ढेलों को तोडना, घास-पात तथा कंकर बीनकर अलग करना तथा मिट्टी की दरेसी करना 1.5 मी० उठाना तथा 50 मीटर दूरी के लिए। कठोर मिट्टी में मिट्टी की कुटाई मानव द्वारा या प्लेन रोलर द्वारा ।(जि.स्त.दर	100.80	घ.मी.	100	100.00	10080.00	10080.00
3	धामन/घास बीज बुवाई बनाये गये रिज पर दो लाईनों में (जि.स्त.दर.अनु.2010पृ.सं020 क्र.सं. 129)	105.00	मीटर	0.6	0.60	63.00	63.00
4	धामन घास बीज	1.00	कि.ग्रा	-	61.50		61.50
	<b>योग</b>					<b>10192.00</b>	<b>10253.50</b>
	<b>योग</b>						<b>10253.50</b>
	<b>जोडा 4: कन्टोजेन्सी</b>						<b>410.14</b>
	<b>योग</b>						<b>10663.64</b>
	लागत श्रम भाग						<b>10192.00</b>
	लागत सामग्री भाग						<b>471.64</b>
	<b>कुल योग</b>						<b>10663.64</b>

**Say      11000.00**

## लागत तकमीना

नाम जल ग्रहण क्षेत्र—श्री कृष्णनगर रामनगर

कार्य का नाम— कृषि भूमि पर  
वेजीटेटिव बन्ड

1.00

22.50

क्र.सं.	विवरण	मात्रा	इकाई	दर		राशि	
				श्रम	कुल	श्रम	कुल
1	डाग बेलिंग 2.5 से 5 सेमी गहराई तक (जि.स्त. दर.अनु.)	45.00	मीटर	0.7	0.70	31.50	31.50
2	मिट्टी का कार्य बन्ध में (सूखी या गीली) 15 सेमी परत में डालना, ढेलों को तोडना, घास—पात तथा कंकर बीनकर अलग करना तथा मिट्टी की दरेसी करना 1.5 मी० उठाना तथा 50 मीटर दूरी के लिए। कठोर मिट्टी में मिट्टी की कुटाई मानव द्वारा या प्लेन रोलर द्वारा।(जि.स्त.दर	101.25	घ.मी.	100.00	100.00	10125.00	10125.00
3	धामन/घास बीज बुवाई बनाये गये रिज पर दो लाईनों में (जि.स्त.दर.अनु.)	67.50	मीटर	0.6	0.60	40.50	40.50
4	धामन घास बीज	1.00	कि.ग्रा	-	61.50		61.50
	<b>योग</b>					<b>10197.00</b>	<b>10258.50</b>
	<b>योग</b>						<b>10258.50</b>
	<b>जोडा 4: कन्टोजेन्सी</b>						<b>410.34</b>
	<b>योग</b>						<b>10668.84</b>
	<b>लागत श्रम भाग</b>						<b>10197.00</b>
	<b>लागत सामग्री भाग</b>						<b>471.84</b>
	<b>कुल योग</b>						<b>10668.84</b>

Say

11000.00

## MODEL ESTIMATE

नाम जल ग्रहण क्षेत्र— श्री कृष्णनगर रामनगर

कार्य का नाम—कृषि भूमि पर वानिकी पौधारोपण

पौधो की संख्या: 100

क्र.सं.	विवरण	मात्रा	इकाई	दर		राशि	
				श्रम	कुल	श्रम	कुल
1	45ग45ग45 सेमी. माप के गड्डे करना कठोर मिट्टी 400 गड्डे / हैक्टर (जि.स्त.दर.अनु.	100	संख्या	6.80	6.80	680.00	680.00
2	पौधे रोपण करना (जि.स्त.दर.अनु.2011	100	संख्या	3.00	3.00	300.00	300.00
3	पौधों की कीमत	108	संख्या	-	5.00	-	540.00
4	पौधों का परिवहन पौधे भराई एवं खाली कराई सहित 5 कि०मी. दूरी तक के लिए	108	संख्या / 1000	-	908.21	-	98.09
5	पौधे रोपण के समय डीएपी डालना	3	कि.ग्रा.	-	10.00	-	30.00
6	दीमक नियन्त्रण हेतु एन्डोसल्फान 4: चूर्ण	10	कि.ग्रा.	-	12.00	-	120.00
7	पौधो में उर्वरक एवं कीट ना तक दवाई डालना	100	संख्या	0.21	0.21	21.00	21.00
	<b>योग</b>					<b>1001.00</b>	<b>1789.09</b>
	<b>योग</b>						<b>1789.09</b>
	<b>जोडा 4: कन्टोजेन्सी</b>						<b>71.56</b>
	<b>योग</b>						<b>1860.65</b>
	लागत श्राम भाग						<b>1001.00</b>
	लागत सामग्री भाग						<b>859.65</b>
	<b>कुल योग</b>						<b>1860.65</b>
						<b>Say</b>	<b>1900.00</b>

Say 19 रु / पौधा

## लागत तकमीना

कार्य का नाम – कम्पोस्ट पिट यूनिट

क्र.सं.	विवरण	मात्रा	इकाई	दर		राशि	
				श्रम	कुल	श्रम	कुल
1	नींव, खाई परनाला में 1.5 गहराई तक मिट्टी का खुदाई करना, तल को कूटना, पानी डालना, बगल को संवारना, खुदी मिट्टी को बाहर निकालना, नींव भरने के बाद खाली स्थानों को पुनः मिट्टी से भरना तथा बची हुई मिट्टी को 50 मीटर दूरी तक निस्तारण करना। सख्त, चिकनी,	10.80	घ.मी	100.00	100.00	1080.00	1080.00
2	सिंगल सुपर फास्फेट	150.00	कि.ग्रा.	-	4.00	-	600.00
3	यूरिया	30.00	कि.ग्रा.		6.00	-	180.00
4	कल्चर पैकिंट	3.00	संख्या	-	10.00	-	30.00
	<b>योग</b>					<b>1080.00</b>	<b>1890.00</b>
	<b>योग</b>						<b>1890.00</b>
	<b>जोडा 4: कन्टोजेन्सी</b>						<b>75.60</b>
	<b>योग</b>						<b>1965.60</b>
	लागत श्रम भाग						<b>1080.00</b>
	लागत सामग्री भाग						<b>885.60</b>
	<b>कुल योग</b>			137.778			<b>1965.60</b>
						<b>Say</b>	<b>2000.00</b>

## लागत तकमीना

कार्य का नाम- फलदार पौधों की यूनिट

यूनिट का क्षेत्रफल: 0.20 हैक्टेयर(55 पौधे / यूनिट)

क्र.सं.	विवरण	मात्रा	इकाई	दर		राशि	
				श्रम	कुल	श्रम	कुल
1	नीव, खाई परनाला में 1.5 गहराई तक मिट्टी का खुदाई करना, तल को कूटना, पानी डालना, बगल को संवारना, खुदी मिट्टीको बाहर निकालना, नीव भरने के बाद खाली स्थानों को पुनः मिट्टी से भरना तथा बची हुई मिट्टी को 50 मीटर दूरी तक निस्तारण करना। सख्त, चिकनी,	40.09	घ.मी.	92.00	92.00	3688.28	3688.28
2	गोबर की खाद	550	कि.ग्रा.	-	2.50	-	1375.00
3	सुपरफास्फेट	20	कि.ग्रा.	-	3.50	-	70.00
4	पोटाश	5.00	कि.ग्रा.	-	4.00	-	20.00
5	यूरिया	12	कि.ग्रा.	-	5.00	-	60.00
6	दीमक की रोकथाम हेतु कीटनाशक दवाई (एन्डोसल्फान 4: चूर्ण)	6	कि.ग्रा.	-	12.00	-	72.00
7	पौधे रोपण करना (जि.स्त.दर.अनु.2011)	55	संख्या	3.00	3.00	165.00	165.00
8	पौधों की कीमत	55	संख्या	-	15.00	-	825.00
9	पौधों पर लगने वाले कीड़े मकोड़ों के नियंत्रण हेतु मोनोक्रोटोफॉस 36 इ.सी	0.25	लीटर	-	360.00	-	90.00
10	पौधों में उर्वरक एवं दवाई डालना (जि.स्त.दर.अनु.2011)	110	संख्या	0.21	0.21	23.10	23.10
	<b>योग</b>					<b>3876.38</b>	<b>6388.38</b>
	<b>योग</b>						<b>6388.38</b>
	<b>जोडा 4: कन्टोजेन्सी</b>						<b>255.54</b>
	<b>योग</b>						<b>6643.92</b>
	लागत श्रम भाग						<b>3876.38</b>
	लागत सामग्री भाग						<b>2767.54</b>
	<b>कुल योग</b>						<b>6643.92</b>
						<b>Say</b>	<b>6700.00</b>

विस्तृत तकमीना

नाम जल ग्रहण क्षेत्र— श्री कृष्णनगर  
गाँव का नाम :

कार्य का नाम— फलदार पौधों की यूनिट

यूनिट का क्षेत्रफल: 0.20 हैक्टेयर (55 पौधे / यूनिट)

क्र.सं.	विवरण	ल.गचौ.गग. = कुल मात्रा
1	नींव, खाई परनाला में 1.5 गहराई तक मिट्टी का खुदाई करना, तल को कूटना, पानी डालना, बगल को संवारना, खुदी मिट्टी को बाहर निकालना, नींव भरने के बाद खाली स्थानों को पुनः मिट्टी से भरना तथा बची हुई मिट्टी को 50 मीटर दूरी तक निस्तारण करना। सख्त, चिकनी,	$55 \times 0.90 \times 0.90 \times 0.90 = 40.09$ घ.मी
2	गोबर की खाद	55 गड्डे / 10 कि.ग्रा. / गड्डा = 550 कि.ग्रा.
3	सुपरफास्फेट	55 गड्डे / 0.35 कि.ग्रा. / गड्डा = 19.25 कि.ग्रा. say 20 कि.ग्रा.
4	पोटाश	55 गड्डे / 0.08 कि.ग्रा. / गड्डा = 4.4 कि.ग्रा. say 5.00 कि.ग्रा.
5	यूरिया	55 गड्डे / 0.22 कि.ग्रा. / गड्डा = 12.10 कि.ग्रा. say 12.00 कि.ग्रा.
6	दीमक की रोकथाम हेतु कीटनाशक दवाई (एन्डोसल्फान 4: चूर्ण)	55 गड्डे / 0.10 कि.ग्रा. / गड्डा = 5.50 कि.ग्रा. say 6.00 कि.ग्रा.
7	पौधे रोपण करना	55
8	पौधों की कीमत	55
9	पौधो पर लगने वाले कीड़े मकोडो के नियंत्रण हेतु मोनोक्रोटोफॉस 36 इ.सी	0.25 लीटर. / यूनिट
10	पौधों में उर्वरक एवं दवाई डालना	110

10 यूनिट

## DITCH CUM BUND

### DETAILED ESTIMATE AND ABSTRACT OF COST

#### Name Of Work: Construction Of Ditch Cum bund (DCB)

क्र.सं.	कार्य विवरण	मात्रा	दर	प्रति	राशि
1	बण्ड का ले आउट	2x1=2.00	0.70	Met.	1.40
2	जंगल की सफाई, भारी झाड़ियों तथा 30 से.मी. लपेट तक के पोधों को काटने समेत।	2.0x1.0=2.00	1.70	Sqm.	3.40
4	नींव व ट्रेंचेच मे मिट्टी की खुदाई का कार्य, खुदी हुई मिट्टी का निस्तारण तथा समतल करना। सख्त मिट्टी में/ककरं मिली मिट्टी में	$1 \times \frac{1.50 + 0.9 \times 1.20}{2} = 1.44$	92.00	Cum.	132.50

**TOTAL 137.30**

Add 4% Contingency 5.49

G. TOTAL 142.79

**Say Rs. 143.00**

Per Met.

DCB Work in 1400.00 Meter (10 Ha)=1400.00x143.00= 200200.00

Cost Per Ha.=200200.00/10 =20020.00

**Say Rs.=20000.00**

(Rupees Twenty Thousand only)

Note: Rate has been taken from the BSR issued by Zila Parishad Jodhpur on 8/4/2011.

W. D. T. (Technical)

I. W. M. P.

P. S. Phalodi

A. En. & P. I. A.

I. W. M. P.

P. S. Phalodi

**Name Of Work: Construction Of Ditch Cum Bund (DCB)**

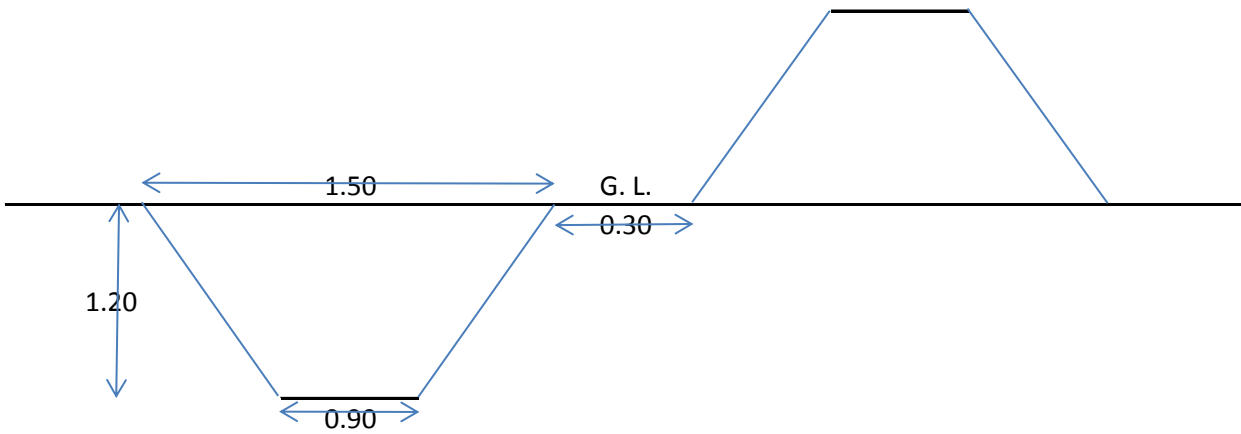

**X-Section Of Ditch Cum bund (DCB)**

All Dimensions are in Meter  
Not in Scale

W. D. T. (Technical)  
I. W. M. P.  
P. S. Phalodi

A. En. & P. I. A.  
I. W. M. P.  
P. S. Phalodi

## DESIGN OF BUND IN ARABLE LAND TYPE-I

Name of Water Shed : Shri Krishan Nagar (Jodhpur -35) IWMP

Name of P.S. Phalodi

$$V.I = 0.305 (XS+Y)$$

$$0.305( 0.8 \times 1 + 1.0)$$

$$V.I = 0.549$$

V.I Vertical interval

X= Rain Fall Factor

0.8

Y= Factor due to soil infiltration & Crop cover

1

S= Percent slope

1

$$He = \frac{(Re \times VI)^{1/2}}{(50)^{1/2}}$$

$$He = 0.549 \quad \text{Say} \quad 0.50 \text{ Cm.}$$

He Depth of impounding

Re 24Hour rainfall excess in Cms. for 10 year recurrence interval

45.62

V.I Vertical interval

0.549

$$\text{Total Height of Bund} = 0.50 + 0.30 = 0.80 \text{ Cms}$$

$$\text{Top width of Bund} = 0.35 \text{ Cms.}$$

$$\text{Bottom width of Bund} = 2.75$$

$$\text{Cross section of bund} = \frac{(\text{Top width of Bund} + \text{Bottom width of Bund}) \times \text{Height}}{2}$$

$$X \text{ Section} = \frac{(0.35 + 2.75) \times .8}{2}$$

$$X \text{ Section} = 1.24 \text{ Sqmt.}$$

## DESIGN OF EARTHEN BUND TYPE-II

Name of Water Shed : Shri Krishan Nagar (Jodhpur -35) IWMP

Name of P.S. Phalodi

$$V.I = 0.305 (XS+Y)$$

$$V.I = \frac{0.305(0.8 \times 2 + 1.0)}{0.793}$$

V.I Vertical interval

X= Rain Fall Factor

0.8

Y= Factor due to soil infiltration & Crop cover

1

S= Percent slope

2

$$He = \frac{(Re \times VI)^{1/2}}{(50)^{1/2}}$$

$$He = \frac{0.723 \times 45.62}{7.07} \text{ Say } 0.75 \text{ Cm.}$$

He Depth of impounding

Re 24Hour rainfall excess in Cms. for 10 year recurrence interval 45.62

V.I Vertical interval 1.037

$$\text{Total Height of Bund} = 0.75 + 0.45 = 1.20 \text{ Cms}$$

$$\text{Top width of Bund} = 0.6 \text{ Cms.}$$

$$\text{Bottom width of Bund} = 4.20$$

$$\text{Cross section of bund} = \frac{(\text{Top width of Bund} + \text{Bottom width of Bund}) \times \text{Height}}{2}$$

$$X \text{ Section} = \frac{(0.6 + 4.20) \times 1.20}{2}$$

$$X \text{ Section} = 2.88 \text{ Sqmt.}$$

## DESIGN OF EARTHEN BUND TYPE -III

Name of Water Shed : Shri Krishan Nagar (Jodhpur -35) IWMP

Name of P.S. Phalodi

$$V.I = 0.305 (XS+Y)$$

$$V.I = 0.305( 0.8 \times 3 + 1.)$$

V.I	Vertical interval	
X=	Rain Fall Factor	0.8
Y=	Factor due to soil infiltration & Crop cover	1
S=	Percent slope	3

$$He = \frac{(Re \times VI)^{1/2}}{(50)^{1/2}}$$

$$He = .946 \quad \text{Say} \quad 0.95\text{Cm.}$$

He	Depth of impounding	
Re	24Hour rainfall excess in Cms. for 10 year recurrence interval	45.62
V.I	Vertical interval	0.95

Total Height of Bund=	0.95 + 0.55 =	1.50 ms
Top width of Bund	=	0.75 ms.
Bottom width of Bund	=	5.25

$$\text{Cross section of bund} = \frac{(\text{Top width of Bund} + \text{Bottom width of Bund}) \times \text{Height}}{2} \quad \text{X Section} = \frac{(0.75 + 5.25) \times 1.50}{2}$$

$$\text{X Section} = 4.50 \text{ sqmt.} \quad \text{Say } 4.50 \text{ sqmt.}$$

## CROSS SECTION OF EARTHAN BUND TYPE I

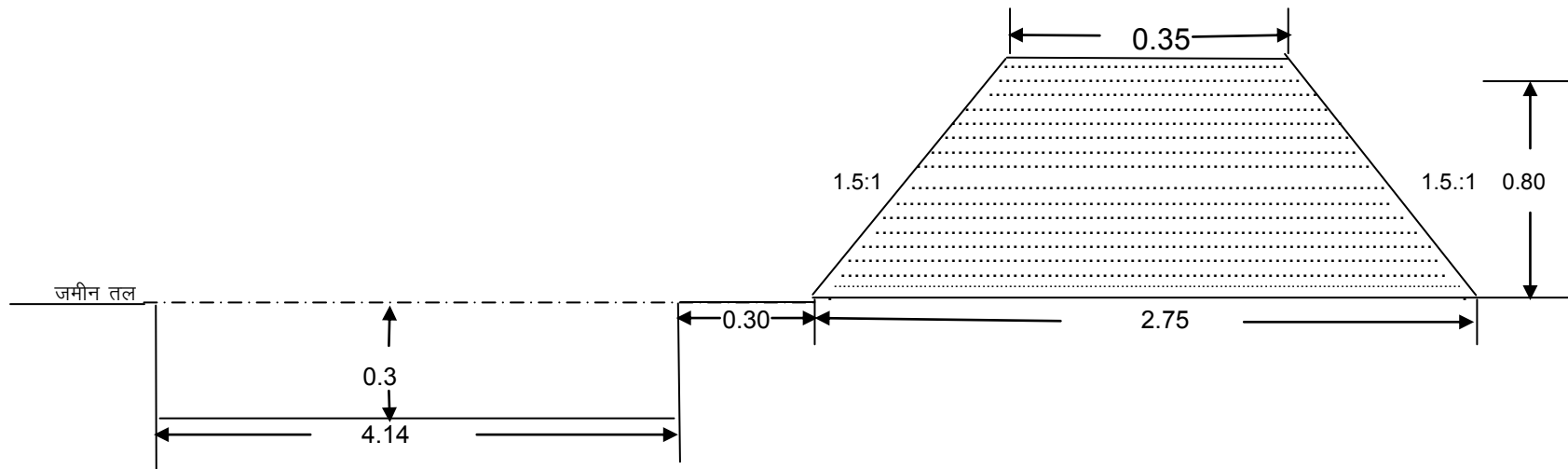

(All Measurement in Meter)

$$\begin{aligned} \text{Cross Sec.} &= \frac{(2.75+0.35) \times 0.80}{2} \\ &= 1.24 \text{ Sqm} \end{aligned}$$

## CROSS SECTION OF EARTHAN BUND TYPE - II

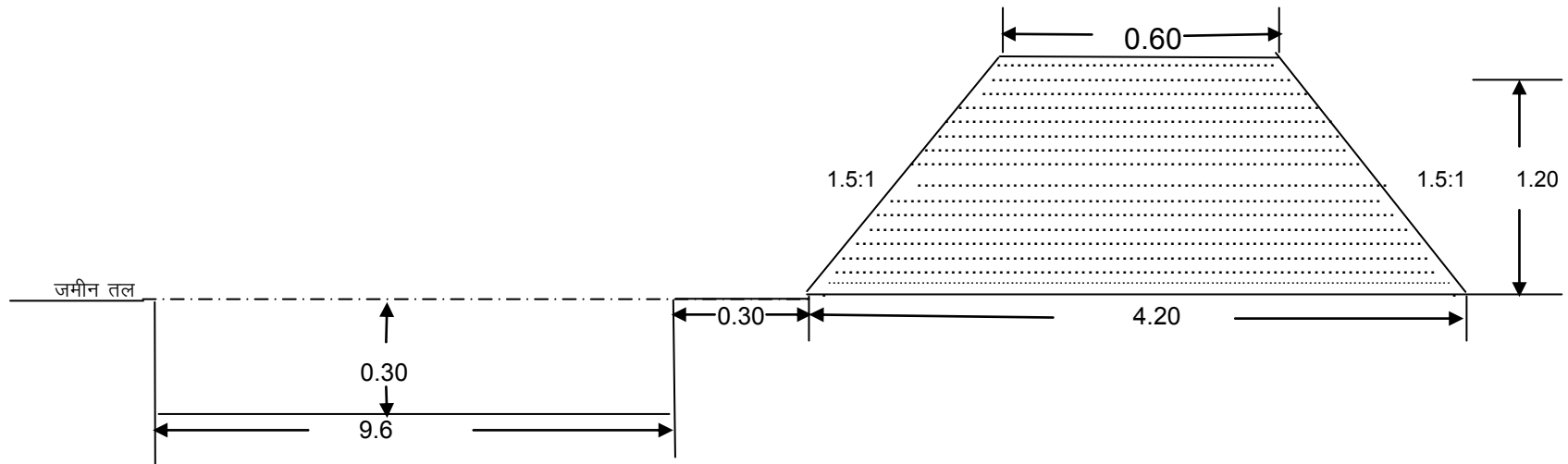

All Measurement in Meter)

$$\text{Cross Sec.} = \frac{((4.20+0.60)) \times 1.20}{2} = 2.88 \text{ Say } 2.88 \text{ sqmt.}$$

$$\text{Cross Sec.} = 2.88 \text{ sqmt.}$$

## CROSS SECTION OF EARTHAN BUND TYPE - III

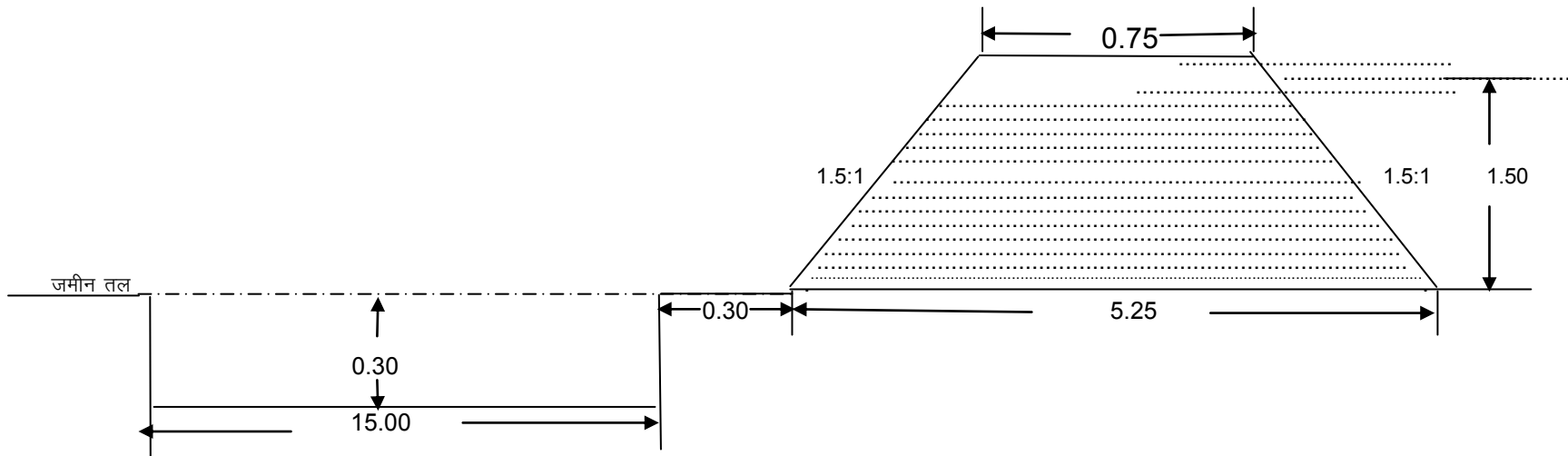

(All Measurement in Meter)

$$\begin{aligned} \text{Cross Sec.} &= ((5.25+0.75) / 2) \times 1.50 \\ &= 4.50 \text{ Sqm} \end{aligned}$$

## CROSS SECTION OF DITCH CUM BUND FENCING

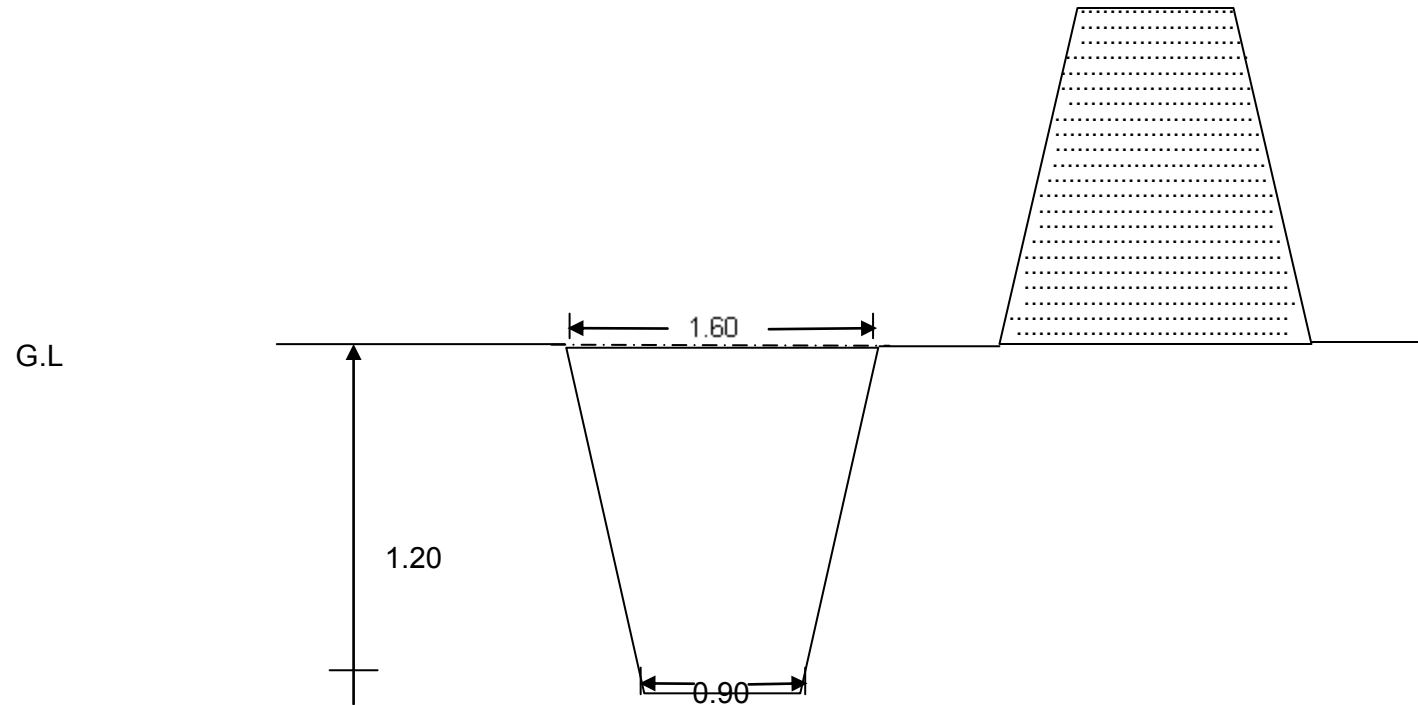

$$\begin{aligned} \text{Cross Sec.} &= \frac{(1.50+0.0.90)}{2} \times 1.20 \\ &= 1.44 \text{ Sqm} \end{aligned}$$

## CROSS SECTION OF L.S.C.D

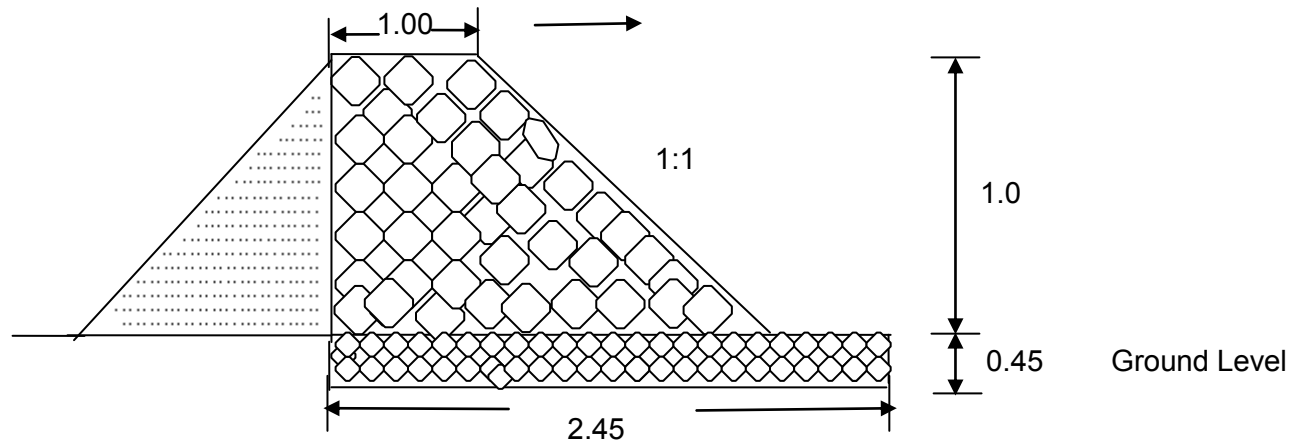

$$\begin{aligned} \text{Cross Sec.} &= ((1.00+2.00) / 2) \times 1.00 \\ &= 1.50 \text{ Sqm} \end{aligned}$$

## CROSS SECTION OF CONTOUR FURROW

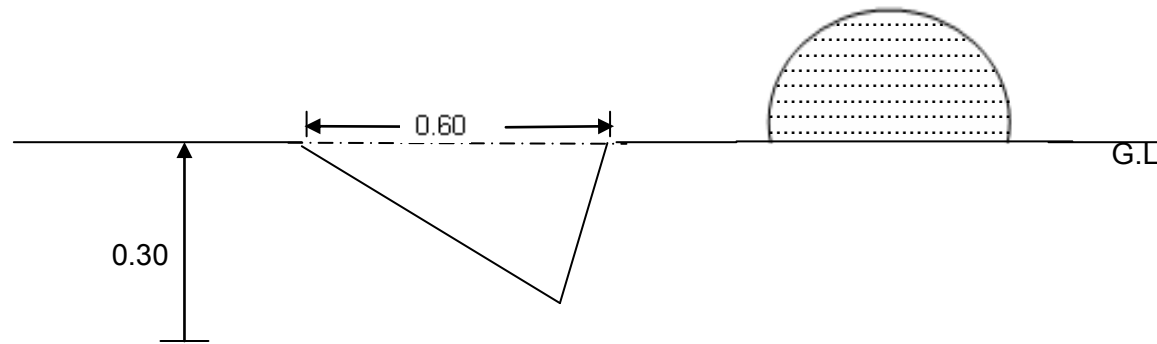

$$\begin{aligned}\text{Cross Sec.} &= \frac{1}{2} \times 0.60 \times 0.30 \\ &= 0.09 \text{ sqm.}\end{aligned}$$





**विभिन्न खरीफ फसलों की अनुमानित आदान लागत**

क्रम सं.	मद	प्रावधान प्रति हैक्टर	फसलवार इकाई लागत प्रति हैक्टा (रु.)						
			मात्रा	मक्का	ज्वार	मोठ	मूंग	चावल	सोयाबीन
1	बीज	मक्का-25 लीोग्राम, ज्वार-10 किलोग्राम, मोठ-10 किलोग्राम	106.5	400	600	1480	1100	2400	1680
2	बीपचार								
3	(अ) एजोटोबेक्टर	600 ग्राम (3 पैकेट)	45	45	45	45	45	45	45
4	(ब) पी.एस. बी.	600 ग्राम (3 पैकेट)	46	46	46	46	46	46	46
5	(स) थाइरम		25	10	15	15	15	75	25
6	उर्वरक								
7	I. डी.एपी		1602.48	1602.48	1602.48	1602.48	1602.48	1602.48	1602.48
8	II. यूरिया		1214.928	759.33	0	0	0	58.41	759.33
9	III. जिप्सम	250 किलोग्राम	250	250	250	250	250	250	250
10	सूक्ष्म पोषक तत्व	250 किलोग्राम	1000	1000	1000	1000	1000	0	1000
11	खरपतपारनाशी		500	500	1000	1000	1000	0	1000
12	पौध संरक्षण		500	500	1300	1300	1300	1900	1100
		<b>योग</b>	<b>5289.91</b>	<b>5112.81</b>	<b>5858.48</b>	<b>6738.48</b>	<b>6358.48</b>	<b>6376.89</b>	<b>7507.81</b>

विभिन्न रबी फसलों की अनुमानित आदान लागत

क्रम सं.	मद	प्रावधान प्रति हैक्टर	फसलवार इकाई लागत प्रति हैक्टा (रु.)			
		मात्रा	चना	सरसों	जौ	गैहूं
1	बीज	चना-80 लीोग्राम, सरसों-4 किलोग्राम, जौ-10 किलोग्राम, गैहूं-125 किलोग्राम	3200	116	2500	2500
2	बीपचार					
3	(अ) एजोटोबेक्टर/राइजोबिया	600 ग्राम (3 पैकेट)	45	45	45	45
4	(ब) पी.एस. बी.	600 ग्राम (3 पैकेट)	46	45	45	45
5	(स) थाइरम/बाविस्टीन/मेन्कोजेब	चना-बाविस्टीन 40 ग्राम, सरसों-मेन्कोजेब 10ग्राम, जौ-थाइरम 375	30	10	150	150
6	उर्वरक					
7	I. डी.एपी	चना-54.25 कि.ग्रा., जौ-33 कि.ग्रा एवं सरसों, गैहूं-60 कि. ग्रा.	987.8935	1092.6	600.93	1092.6
8	II. यूरिया	जौ एवं सरसों में 52 कि.ग्रा., गैहूं-60 कि.ग्रा.	0	276.12	276.12	318.6
9	III. जिप्सम	250 किलोग्राम	250	250	250	250
10	सूक्ष्म पोषक तत्व	250 किलोग्राम	1000	1000	1000	1000
11	खरपतपारनाशी		400	400	350	600
12	पौध संरक्षण		1500	1500	500	500
		<b>योग</b>	<b>7458.89</b>	<b>4734.72</b>	<b>5717.05</b>	<b>6501.2</b>

Scheme: IWMP

Watershed: Shri Krishna Watershed: Shri Krishan Nagar (Jodhpur-35)

Panchayat Samiti:Phalodi

District: Jodhpur

**Name Of Work: Construction Of Gully Plugging**

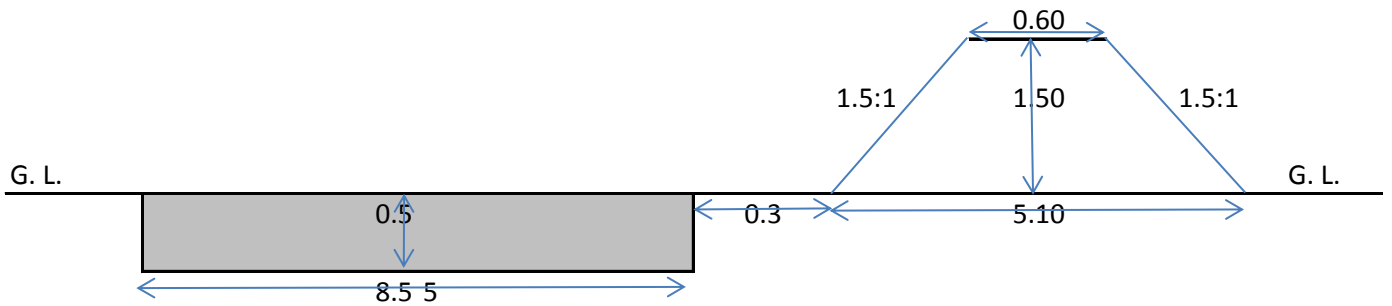

**X-Section Of Gully Plugging**

All Dimentions are in Meter

Not in Scale

W. D. T. (Technical)

I. W. M. P.

P. S. Phalodi

A. En. & P. I. A.

I. W. M. P.

P. S. Phalodi

## Model Estimate of Tool Kit

### Household Production System ( for Marginal farmer and Land less labour)

Service sector- Tool Kit Specification Trade wise Detail of tools requirement in one set

#### 1. One set of carpentry tools

**COST Rs. 4000/= per Kit**

S.No.	Name of tools	Specfication	Quantity
1	Hand saw	Size 15"	1 No.
2	Hand saw	Size 12"	1 No.
3	Screw driver	Size 8" x 25 mm	1 No.
4	Combination pliers	Size 8" Make - Taparia	1 No.
5	Charsi with handle	Size 25 mm	1 No.
6	Charsi with handle	Size 18 mm	1 No.
7	Charsi with handle	Size 10 mm	1 No.
8	Wooden Randda	Big - Made of Sagwan	1 No.
9	Wooden Randda	Small - Made of Sagwan	1 No.
10	File half round	Make JK	1 No.
11	File regular	Make JK	1 No.
12	Tee bar carpenter frame(sikanja) for wooden	Size 4' x 2"	1 No.
13	Stone silly	size 6" - ISI Mark	1 No.
14	Basola with handle	Weight 800 gram	1 No.
15	Ball peen hammer	Weight 300 gram -Make Ambica	1 No.
16	Cross peen hammer	Weight 500 gram -Make Ambica	1 No.
17	Measurement tape	Size 10 feet- Make freeman	1 No.
18	Pincer	Size 200 mm	1 No.
19	Girmt	Size 1/2"	1 No.
20	Tri Square	Size 8"	1 No.
21	Hand operated drill	Size 1/4"	1 No.
22	Steel box for Tools	Size (22" x 11" )- G.I. sheet	1 No.

#### 2. One set of Mason tools

**COST Rs. 2000/= per Kit**

S.No.	Name of tools	Specfication	Quantity
1	Karni	Size - Big	1 No.
2	Karni	Size - small	1 No.
3	Mashtar wooden	Size 36" Made of Sagwan	1 No.
4	Mashtar wooden	Size 24" Made of Sagwan	1 No.
5	Mashtar wooden	Size 15" Made of Sagwan	1 No.
6	Gurmala		1 No.
7	Soot		1 No.
8	Sabble	Heavy iron	1 No.
9	L shape measurement (Gunia)		1 No.
10	Level pipe ( 25 Foot)	5 mm	1 No.
11	Chiesal	Size 6" , 8" Make - Taparia	1 No.
12	Ball pine hammer	Weight 500 gm Make - Ambica	1 No.
13	Cross pine hammer	Weight 300 gm Make - Ambica	1 No.
14	Aluminium rib	Size 60" x 4" x 1.5"	1 No.
15	Measurement Tape	Size 10 feet Make freemans	1 No.
16	Canvas bag for above tools	Made of Heavy canvas	1 No.

### 3. One set of Pottery tools

COST Rs. 12000/= per Kit

S.No.	Name of tools	Specification	Quantity
1	Clay lump beating hammer	MS pat. Size - D100 - 120mm X T5-6 mm with iron pipe handle	1 No.
2	Wooden hammer ( Thapa )	Sheesam Woodv . Size - D6-7" X T1.25".handle-L6"	1 No.
3	Tasla	MS sheet. Size - 15", SWG-20	1 No.
4	Spade ( Phawda )	MS sheet. Size - L 10"x w10", SWG-20.fitted with wooden Handle	1 No.
5	Kamdai	Wooden Size - 2"x1-1.25" approx. Arch shap	1 No.
6	Pindi Cement	Varius Size	3 No.
7	Decoration tools	MS ( Banki, Sua, Piyali, Patti)	8 No.
8	Decoration Wheel	Size-H 16" x D 12-15". Tripod Structure. Fittedv withb double Ball Bearing.Iron sheet 5mm	1 No.
9	Manual Potter Wheel	Outer Dia-inner Plate size- D 300mm x T-20mm. T-WT-17 Kg minimum(Cast iron body). Tripod Casted iron Structure with Ball bearing . 2 nos. of outer rings made of T or steal of 12mm Dia. Cross Wooden Support Structure	1 No.

**4. One set of Footwear (Mojari) tools****COST Rs. 12000/= per Kit**

S.No.	Name of tools	Specification	Quantity
1	Ball pine hammer	Drop forged steel ,Induction hardened, Seasoned wood handle,WT-300 gms with wood handle, Nilon hammer(L 240mm, head size L80xD300mm)	1 No.
2	Wooden Block	Size- 18"x W4"xT4"	1 No.
3	Pincer	Size- 8"	1 No.
4	Scissors	Size- 9", Steel Body, Brass Handle	1 No.
5	Bodam/Shoeanvil	Graded CI with 3 phases,WT-4 kg. approx	1 No.
6	Cutting Blade Set (Ramp )	Steel with Wooden Handle, Size-L 150x W 30x T 6mm	1 set
7	Stitching Awl	Steel with Sheesam Wood Handle.	1 No.
8	Sharpening Stone	Size 150x50x25mm,109 no.	1 No.
9	Shoe measuring Tape	Size-2' fibre/good quality plastic material	1 No.
10	Lock Punch Set	Steel	1 No.
11	Bye let setting tool	Steel	1 No.
12	Round whole punch set	Steel, Size- L 100 Range-1 to 10	1 set (10 pcs.)
13	Design punch set	En-9 steel, Size- L100	1 set (3 pcs.)
14	Zig zag Steel Scissors	Steel, Size- 8 1/2". Grooves on cutting edge.	1 No.
15	Pattern cutting Knife	Steel, Size-6"	1 No.
16	PP Block	Size-L 6"x W 6" T 20mm	1 No.
17	Steel Scale	Size - 12" and 24".	1 No.
18	Leather Scraping Brush	Size-8" with wooden Handle	1 No.
19	Adhesive Brush	Size-10 mm,12mm, 25mm.	1 No.
20	Spring Driver	Steel -Size 9"	1 No.
21	Sant	Steel - H 6" WT-1 kg.	1 No.
22	Sizeore Passing	Steel -Size 8"	1 No.
23	Thread cutter	Steel with plastic Handle, Size-L 100 mm.	1 No.
24	Number sety	Steel	1 set (10 pcs.)
25	Capsol Punch	Size (8-10-12-16)	1 set
26	Brush	Size-10 mm,12mm, 25mm.	1 No.
	Machine Tools		
27	HD Flat Bad Swing Machine	31 K. Branded Company	1 No.

**5.One set of Blacksmith Tools****COST Rs. 6000/= per Kit**

<b>S.No.</b>	<b>Name of tools</b>	<b>Specfication</b>	<b>Quantity</b>
1	Big Hammer	Ghon-5 kg	1 No.
2	Hammer	Ghon-1 kg	1 No.
3	Hammer	Ghon- 1/2 kg	1 No.
4	Anvil - chouka	Ghon-10 kg	1 No.
5	Chisrl-3Nos	Ghon-1 kg, 500 kg.,750 kg.	1 No.
6	Measurement Tape	3 MTR	1 No.
7	Triangle	6"	1 No.
8	plie Taparia	8"	1 No.
9	Screw driver Taparia	10"	1 No.
10	Tin	10"	1 No.
11	Hand operated electric hand drill	-	1 No.
12	Sansasi-flat and round	-	1 No.
13	Table Vice	-	1 No.
14	Haksa Frame Poland type	-	1 No.

**5.One set of Blacksmith Tools****COST Rs. 6000/= per Kit**

<b>S.No.</b>	<b>Name of tools</b>	<b>Specfication</b>	<b>Quantity</b>
1	Hammer	500 gm	1 No.
2	Hammer	1 kg	1 No.
3	Plies Taparia	8"	1 No.
4	Screw driver Taparia	6"-8"-12"	1 No.
5	Pincer - 6"	6"	1 No.
6	Nose plier-6"	6"	1 No.
7	Alignment equipment cycle wheel		1 No.
8	Anivil-Chowka	5 kg.	1 No.
9	Screw wrench	10"	1 No.
10	Hexa Frame poloud type		1 No.
11	Spanner Set fix type 8 pcs	8 pcs	1 No.
12	Electric hand drill machine		1 No.
13	Hand Skipper	10"	1 No.
14	Solution		
15	Water Pump Plier		1 No.
16	Punch	6"	1 No.
17	Hand Scissors	8"	1 No.
18	Oil cane	250 gm	1 No.

# MODEL ESTIMATE FOR ANIMAL HEALTH CAMP

In western Rajasthan due to lack of rainfall the climate is very drastic. Due to which the live stock of western Rajasthan face many problems related to their feed & to maintain their body immunity against climate. Due to which they can face many types of disease due to unfavourable climate condition and mostly by the owner who can use the animals till the animal can give milk after that he can not take care of the animals. Due to this many types of diseases like parasitic diseases it may be inner or outer, milk fever, Mastitis, Mange, tympany, Diarrhoea, fever, Infertility, Pyrometra, Indigestion, FMD, HS, BQ, ETV, etc. are many types of diseases which the animal can generally face due to which owner can face double loss first loss of money on treatment & on effect on animal production. For this in IWMP scheme the animal health camp can be organised in the villages which can come under this scheme. For this one or two camps at Rs. 15,000/- each is organized. Before this first the information of the camp date can be informed to the villagers by various means like posters, banner, ghosti & various other means. After that camp can be organised in which free medicine can be distributed.

Besides that for the seasonal diseases & many other diseases which can be controlled through vaccination the vaccination camp can also be organized in which vaccine for various controlled diseases like FMD, HD & BQ, ETV, Sheep pox, PPR etc. animals can be vaccinated yearly or half yearly.

Per camp cost :-	Medicine	=	21500.00
	Rent of Jeep (for two days)	=	1500.00
	Govt. Doctor or Staff	=	1000.00
	Total =		<b>24000.00</b>

- **General Medicine:-**

- o Antibiotic :-
  - inj. - OTC - 100 ml.
  - inj. - Enrocin - 100 ml.
- o Ointment :-
  - ont. - Loroxine - 100 gm.
  - ont. - Vetmox - 50 gm.
- o Cottons :- 100 gm.

Instruments :-

- Catha tor
- Trokar Canvla
- Forseps
- Teat Syphin
- o Bandage :- 6"
- o Syringe :- 50 ml.
- o Needle :- 16"
- o Mineral Mixture :- pow. = Calfos Ao3 = 1 Kg.
- o Vitamin :- inj. = Vitasef

- **Primary Treatment**

- o P.P :- 100 gm. (5)
- o Mag sulph :- 101 gm. (20)
- o Soda by Carb :- 102 gm. (20)
- o T.T. Oil :- 100 ml (3)
- o Liq :- Notaodom (3)
- o Bolus :- Feedone/Rumtrion

- **Milk Fever** :- inj. - omifex - 450 ml.  
CBG - 1000 ml

- **Mastitis** :- Tub. - Penclastin & H - Z gm

- **Mange** :- inj. - avil 100 ml.  
inj. - Dexona/ 100 ml.

- **Tympany** :- Liq. - Afanil - 100 ml.  
Bolus - Boost nix  
Bolus - Ruwi nox

- **Dishorria** :- Bolus - Botrim  
Bolus - SDM  
inj. - BiOtin 3

- **Fever** :- inj. - proxyvet mp.



फसल प्रदर्शन

Crop-Demonstration (Kharif)

I-INPUTS

A- Crop	:	Bajra
Variety	:	HHB-67,HHB-69
Maturity Period	:	70-85 days
Yield	:	15-25 q/ha
Each Demonstration Area	:	0.5 ha

S.No.	Inputs	Recommended Qty/demo	Rate Rs./kg	Amount
1	Seed	2 kg	36.00	72.00
2	D.A.P.	20 kg	10.44	208.80
3	Urea	25 kg	5.58	139.50
4	Fym	250 kg	2.00	500.00
			Total	<b>920.30</b>
			Say Rs.	<b>920/Demo</b>

B- Crop	:	Moong
Variety	:	K-851
Maturity Period	:	60-80 days
Yield	:	7-10 q/ha
Each Demonstration Area	:	0.5 ha

S.No.	Inputs	Recommended Qty/demo	Rate Rs./kg	Amount
1	Seed	8 kg	70.00	560.00
2	D.A.P.	40 kg	10.44	417.60
3	Fym	250 kg	2.00	500.00
			Total	<b>1477.60</b>
			Say Rs.	<b>1478/Demo</b>

C- Crop	:	Moth
Variety	:	RM-40
Maturity Period	:	60-62 days
Yield	:	6-8 q/ha
Each Demonstration Area	:	0.5 ha

S.No.	Inputs	Recommended Qty/demo	Rate Rs./kg	Amount
1	Seed	5 kg	70.00	350.00
2	D.A.P.	20 kg	10.44	208.80
3	Fym	250 kg	2.00	500.00
			Total	<b>1058.80</b>
			Say Rs.	<b>1059/Demo</b>

D- Crop	:	Gawar
Variety	:	RGM-112 RGC-1017,RGC-936
Maturity Period	:	80-110 days
Yield	:	8-12 q/ha
Each Demonstration Area	:	0.5 ha

S.No.	Inputs	Recommended Qty/demo	Rate Rs./kg	Amount
1	Seed	10 kg	40.00	400.00
2	D.A.P.	40 kg	10.44	417.60
3	Fym	250 kg	2.00	500.00
			Total	<b>1317.60</b>
			Say Rs.	<b>1318/Demo</b>

E- Crop : Til  
 Variety : RT-46,RT-125,RT-127  
 Maturity Period : 70-85 days  
 Yield : 8-10 q/ha  
 Each Demonstration Area : 0.5 ha

S.No.	Inputs	Recommended Qty/demo	Rate Rs./kg	Amount
1	Seed	2 kg	80.00	160.00
2	D.A.P.	25 kg	10.44	261.00
3	Urea	30 kg	5.58	167.40
4	Fym	250 kg	2.00	500.00
			Total	<b>1088.40</b>
			Say Rs.	<b>1088/Demo</b>

औसत चार्ज प्रति प्रदर्शन =  $920+1478+1059+1318+1088$

5

$5863/5 = 1172.60$  रु.

Say= 1172 रु.

**Labour** : The crop demonstration will be a joint venture of the project & farmers. Farmer will provide labour & will perform cultural operation, harvesting & Threshing by themselves.

Note : Cost of seed, fertilizer has been taken from Rajasthan State Seed Corporation & Marketing society.

## PASTURE DEVELOPMENT

### DETAILED ESTIMATE AND ABSTRACT OF COST

Name Of Work: Pasture Development Works in Arable land

क्र.सं.	कार्य विवरण	प्रति	मात्रा	दर	राशि
1	सेवण/धामण घास का बीज एकत्रित/खरीद करना (7 किलो प्रति हेक्टेयर)	Kg.	7	160.00	1120.00
2	7 किलो घास का बीज, खाद, रेत व चिकनी मिट्टी का मिश्रण 1:1:2:2 में बनाकर गोलिया तैयार करना (कुल सामग्री 42 किलो)	Kg.	7	27.84	194.88
3	फरोस पर ड्रिब्लिंग द्वारा घास बीज की गोलियां की बुवाई करना	Kg.	7.00	135.00	945.00

**TOTAL** 2259.88

Add 4 % Contingency 90.40

G. TOTAL 2350.28

**Say Rs. 2350.00**

Per Hact..

**Say Rs.=2350.00 per Hact.**

(Rupees Two Thousand Three hundred Fifty only)

Labour	1369.00
Material	891.00
Contingency	90.40
Total	<u>2350.40</u>

Note: Rate has been taken from the BSR issued by Zila Parishad Jodhpur on 8/4/2011.

W. D. T. (Technical)  
I. W. M. P.  
P. S. Phalodi

A. En. & P. I. A.  
I. W. M. P.  
P. S. Phalodi

**GEOREFERENCED KHASRA MAP**  
**WATERSHED - SHRI KRISHNANAGAR (IWMP)**  
**PANCHAYAT SAMITI - PHALODI**  
**DISTRICT- JODHPUR**

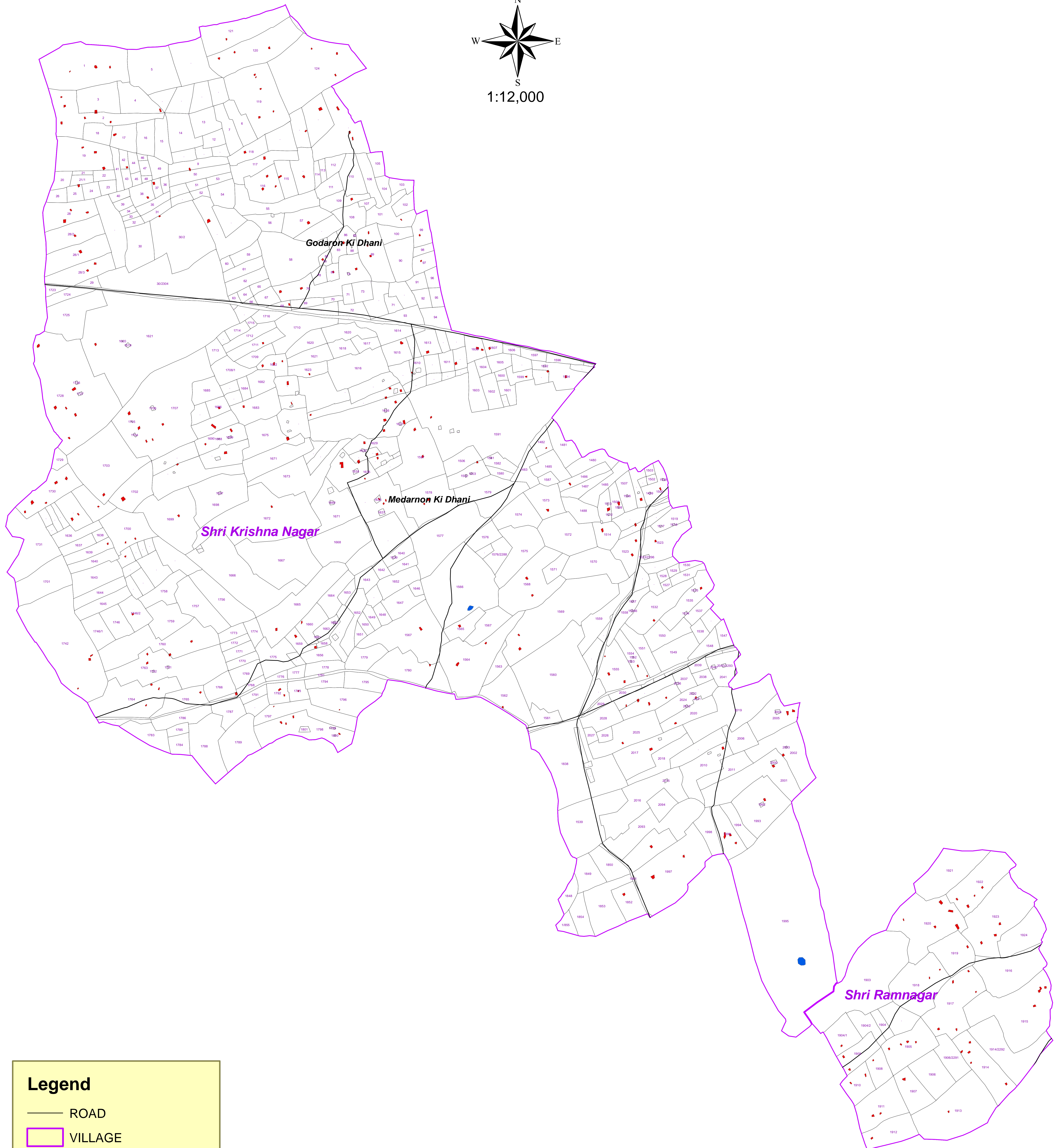
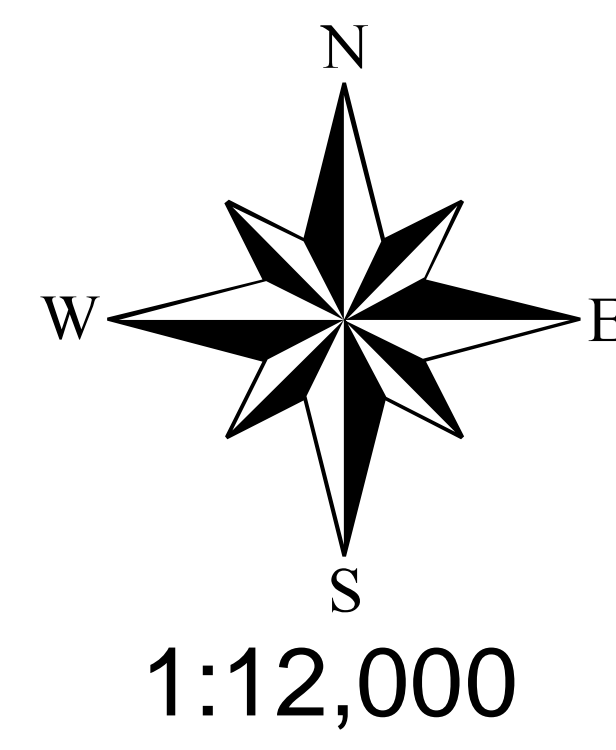

**Legend**

- ROAD
- VILLAGE
- KHASRA BOUNDARY
- SETTLEMENT
- WATERBODY

# LAND USE LAND COVER MAP

## WATERSHED - SHRI KRISHNANAGAR (IWMP)

### PANCHAYAT SAMITI - PHALODI

### DISTRICT- JODHPUR

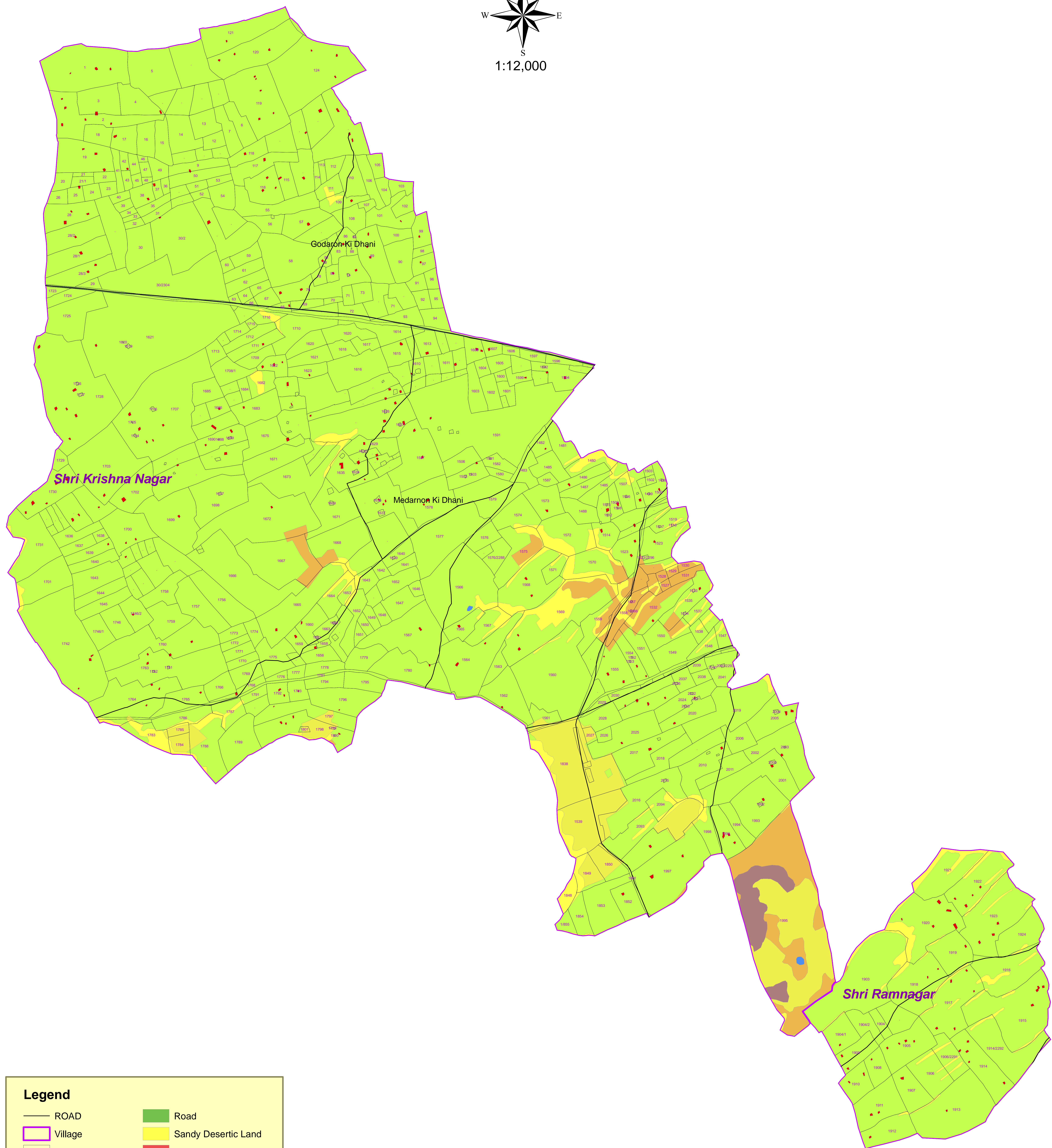
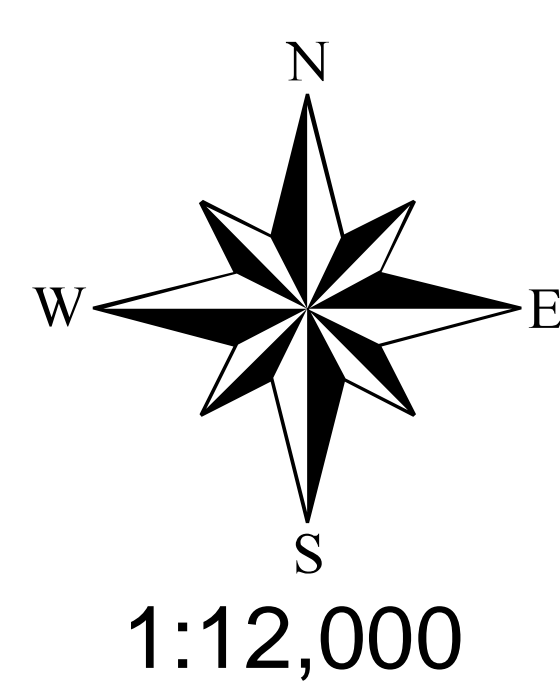

Legend	
— ROAD	■ Road
□ Village	■ Sandy Desertic Land
□ Khasra Boundary	■ Settlement
■ Agriculture	■ Stony Waste
■ Land With Scrub	■ Waterbody
■ Land Without Scrub	

**CARTOSAT-1 (LISS- III MERGE) SATELLITE IMAGE**  
**WATERSHED - SHRI KRISHNANAGAR (IWMP)**  
**PANCHAYAT SAMITI - PHALODI**  
**DISTRICT- JODHPUR**

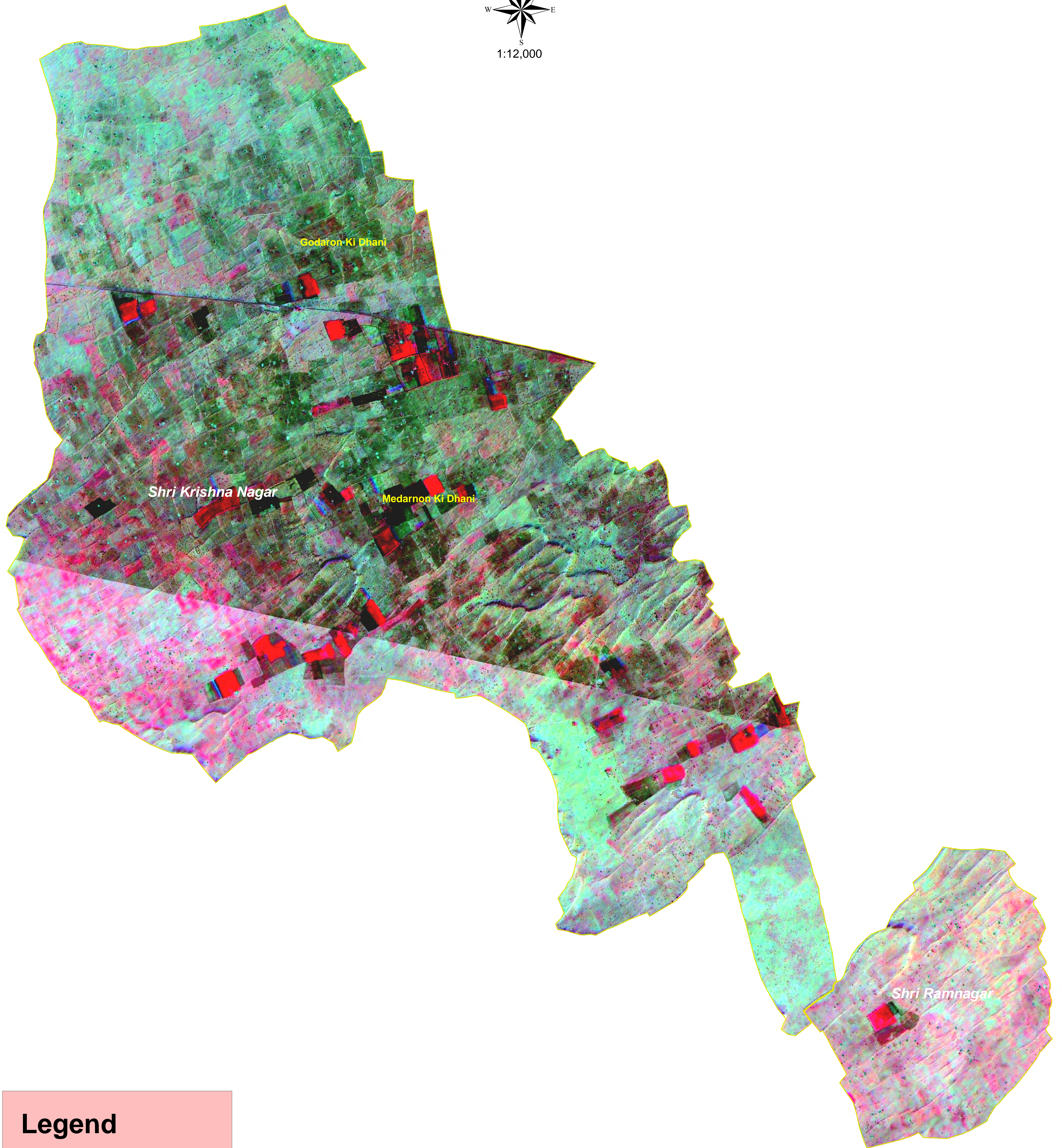
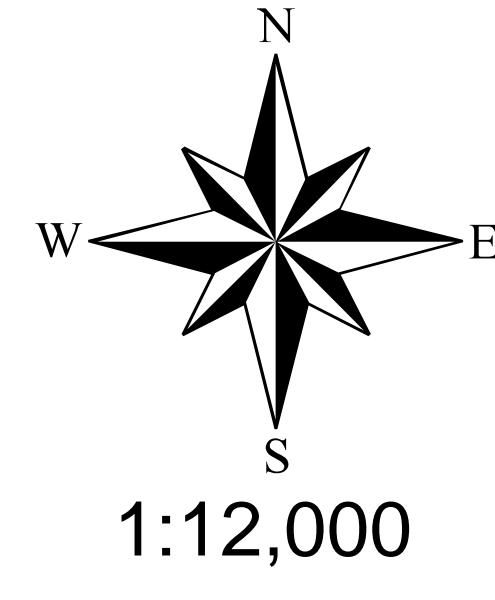

**Legend**

-  VILLAGE
-  SETTLEMENT