

DPR TEMPLATE

Index

<u>S.No</u>	<u>Topics</u>
1.	INTRODUCTION
	Location
	General Features of watershed (Cost and Area details)
	Climatic and Hydrological information
	Other Development Schemes in the project area
	Details of infrastructure in the project areas
	Institutional arrangements (DWDU,PIA, WDT, WC)
2.	SOCIO ECONOMIC FEATURES, PROBLEMS AND SCOPE
	Development Indicators
	Land use
	Agriculture status and Productivity Gap Analysis
	Horticulture/Vegetable/Floriculture status
	Land holding pattern
	Livestock status
	Fodder status
	Farm Implements
	NREGS Status
	Migration details
	Livelihood Details.
	Existing SHG
	Ground Water details
	Drinking Water Status
	Water use efficiency
	Slope details
	Water Budgeting
	Soil Details
	Soil erosion status
3.	PROPOSED DEVELOPMENT PLAN
4.	ANNUAL ACTION PLAN- V CHAPTER
	PROJECT FUND
	Convergence Plan
5.	PROJECT OUTCOMES

<u>S.No</u>	<u>Topics</u>
6.	TECHNICAL DESIGNS AND ESTIMATES FOR PROPOSED ACTIVITIES
7.	ENCLOSURES
	Maps
	Location –District, block, village, watershed location map
	Map of Project with Watershed Boundary demarcation in cadastral map
	Land Use Land Cover map
	Existing water bodies, DLT
	PRA Map (along with photos & paper drawing)
	GIS based intervention map
	Treatment map ie proposed works on revenue map
	Documents of Agreements:
	Proceedings of gram sabha for EPA approval
	Proceedings of gram sabha Resolution for committee constitution
	Documents related to PRA exercise
	Proceedings of gram sabha for DPR approval
	Proceedings of Panchayat Samiti General body for DPR approval
	Watershed Committee Registration certificate
	MoU – PIA – DWMA, PIA – WC(in case of NGO as PIA

Detail of Project

1. Name of Project : Bikaner (IWMP) 28
2. Sanction No. & date of Project : 1/RAJASTHAN/2011-12/IWMP-K-
11013/3/2011/IWMP-30-06-2011
3. Macro & Micros Nos : 4
4. Deviation from Project Sanctioned : No.

Items	As per Project Sanctioned	As proposed in DPR
Project Area	6700 ha.	6700 ha.
Macro/Micro No.	4	4
Name of Gram Panchayats	Indpalsar Sankhlan, Dharmas, Upani	Indpalsar Sankhlan, Dharmas, Upani
Name of Villages	Indpalsar Sankhlan, Indpalsar Gusaisar, Indpalsar Bada, Kalyansar Naya	Indpalsar Sankhlan, Indpalsar Gusaisar, Indpalsar Bada, Kalyansar Naya
Project Cost (Rs. in Lakhs)	1005 Lakh	1005 Lakh

CERTIFICATE

Certified that the undersigned have proposed the appropriate and need based activities required in the watershed project area with active participation of beneficiaries along with consultation of Watershed Committees (WCs). Approval of watershed project plan and DPR as been obtained from WC, Gram Sabha. The plan and DPR document of IWMP-28 project, at P.S. Sri Dungargarh District Bikaner is technically sound, viable and appropriate for implementation during the period 2012- 13 to 2016-17

We recommended tat this plan be sanctioned and put to implementation.

Signature
Chairman

Signature
Secretary

Signature
WDT
member

Signature
Junior
Engineer
P.S.....

Signature
Assistant
Enginner
& PIA
P.S.....

Signature
Project
Manager,
WCDC
Dist.....

CHAPTER – 1

INTRODUCTION

Location

Jodhasar Project is located in Sridungargarh Block, of Bikaner district. The project area is between the Latitude 28°-29° North 73°-74° East & Longitude. It is at a distance of 15 km from its Block head quarters and 85 Kms from the district head quarters. There are 3948 no. of habitations in the Project area and other details are given below.

General features of watershed

S.No.	Name of Project(as per GOI)	BIKNAER (IWMP) 28/11-12			Total
(a)	Name of Catchment	Indpalsar	Dharmas	Upni	
(b)	Name of watershed area (local name)	IWMP-36			
(c)	Project Area (ha)	2730	1850	2647	7227
(d)	Net treatable Area (ha)	2600	1700	2400	6700
(e)	Cost of Project (lac)	390	255	360	1005
(f)	Cost/hectare (lac)	0.15	0.15	0.15	
(g)	Year of Sanction	2011-12	2011-12	2011-12	
(h)	Watershed Code	28	28	28	
(i)	No. of Gram Panchayats in project area	1	1	1	3
(j)	No. of villages in project area	2	1	1	4
(k)	Type of Project	Desert			
(l)	Elevation (metres)				
(m)	Major streams				
(n)	Slope range (%)	0-3%	0-3%	0-3%	

Macro/micro	Name of Gram Panchayat	Name of Villages Covered	Census code of villages	Area
Cluster	Indpalsar Sankhlan	Indpalsar Sankhla Indpalsar Gusaisar	639600 639900	2600
Cluster	Dharmas	Indpalsar Bada	639700	1700
Cluster	Upni	Kalyansar Naya	638500	2400

The watershed falls in Agroclimatic Zone Ic(RF-VLR-SD) The soil texture is Sandy The average rainfall is 26.64 cm. The temperature in the area are in the range between 28.10°-49 ° centigrade during summer and 8.60°-23.60 ° centigrade during winter. The major crops in the area are Guar, Bazara, Moth, Til. 93.66% land is under cultivation. 4.94% land fallow, 2.08% land is wasteland. 16.47% land is irrigated through wells, 247 households are BPL (29.33% households) 10 are landless households (1.18 % households) and 194 household are small and marginal farmers (23.04% household)

Average land holding in the area is 6242 ha., 77% area is single cropped area and 17.68 % is double cropped. The main source of irrigation is well. The average annual rainfall (5 years) in the area is 263.00 mm. The Major streams in the Watershed are Nil. The major festivals in the village are Diwali, Holi, Idulfitur,Dushera, Sawan, Teej, etc. At present this village is having 6681 population with Communities like Jat, Sidh, Nayak, Meghwal, Bavari, Nai,Muslim etc.

Climatic and Hydrological information

Average Annual Rainfall(mm)

Year	Average Annual Rainfall(mm)
2001	162.23
2002	27.00
2003	72.00
2004	127.70
2005	289.70
2006	252.50
2007	250.40
2008	273.10
2009	352.50
2010	527.70
2011	397.00
2012	328.00

Average Annual Rainfall(mm)

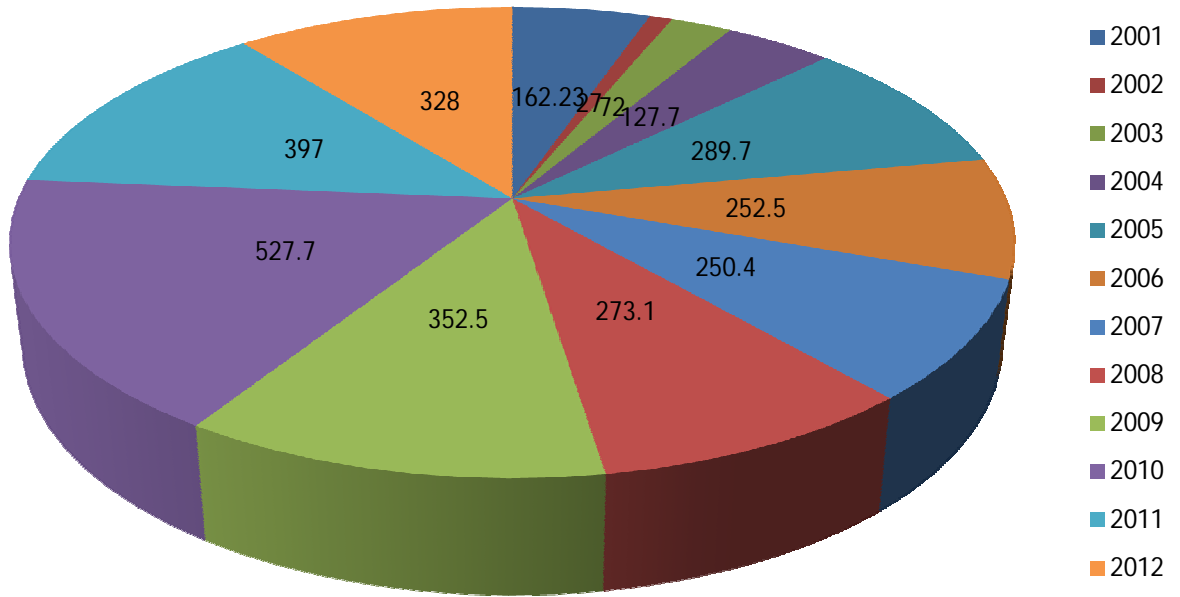

Average Monthly rainfall (last ten years)

Month	Rainfall(mm)
June	152.50
July	250.40
August	273.10
September	352.50

Rainfall(mm)

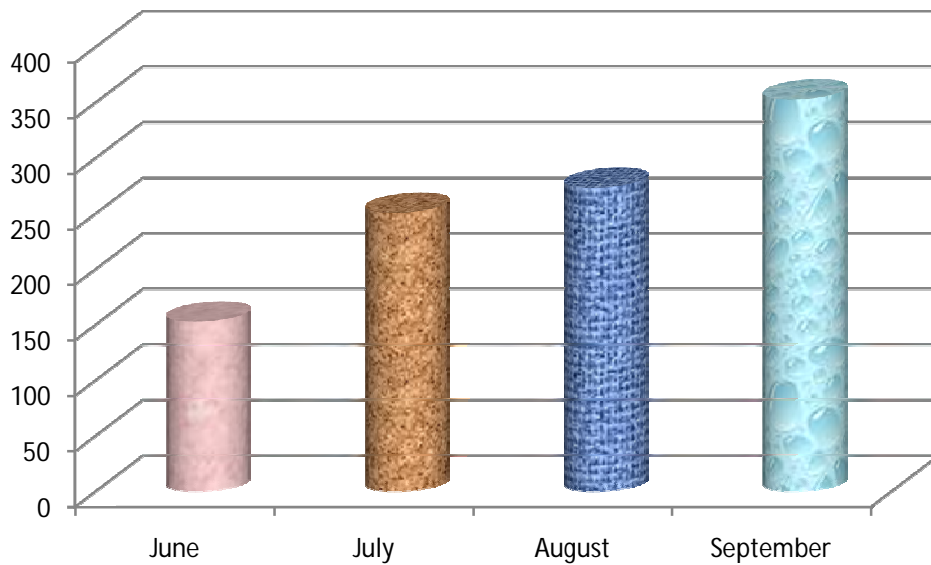

Temperature (Degree C)

Season	Max	Min
i) Summer Season	49.0.c	28.10.c
ii) Winter Season	23.60.c	2.60.c
iii) Rainy Season	38.50.c	28.30.c

Potential Evaporation Transpiration (PET) (mm/day)

Season	PET
Summer May-2009	11.60
Winter June-2009	5.60
Rainy Aug-2009	10.70

Other Development Schemes in the project area

S.No	Scheme	Name of the department	Key interventions under the Scheme	Targeted Beneficiaries
1	MGNREGA	Zila Parishad	Employment Generation	Rural Labours
2	SGSY	Zila Parishad	Livelihood	Rural Population
3	SHG	ICDS	Livelihood	Rural Population : Women & Landless Farmers
4.	TFC	Zila Parishad	Infrastructure Creation	Community
5.	SFC	Zila Parishad	Infrastructure Creation	Community

Details of infrastructure in the project areas

S.N.	Parameters	Status			
(i)	No. of villages connected to the main road by an all-weather road	None			
(ii)	No. of villages provided with electricity	4			
(iv)	No. of educational institutions :	(P)	(S)	(HS)	(VI)
	Primary(P)/ Secondary(S)/ Higher Secondary(HS)/ vocational institution(VI)	03	02	00	0
(v)	No. of villages with access to Primary Health Centre	03			
(vii)	No. of villages with access to Post Office	Nil			
(xi)	Total quantity of surplus milk	694 T/Year			
(xii)	No. of milk collection centers	(U)	(S)	(PA)	(O)
	(e.g. Union(U)/ Society(S)/ Private agency(PA)/ others (O))	0	0	8	0
(xiii)	No. of villages with access to Anganwadi Centre	9			
(xiv)	Any other facilities with no. of villages (please specify)	Water Reservoirs			
(xv)	Nearest KVK	Bikaner			
(xvi)	co-operative society	Bikaner			
(xvii)	NGOs	Nil			
(xviii)	Credit institutions	5			
	(i) Bank Mini	1			
	(ii) Cooperative Society	4			
(xix)	Agro Service Centre's	KVK Bikaner			

DISTRICT : BIKANER

SHOWING PANCHAYAT SAMITI AREA

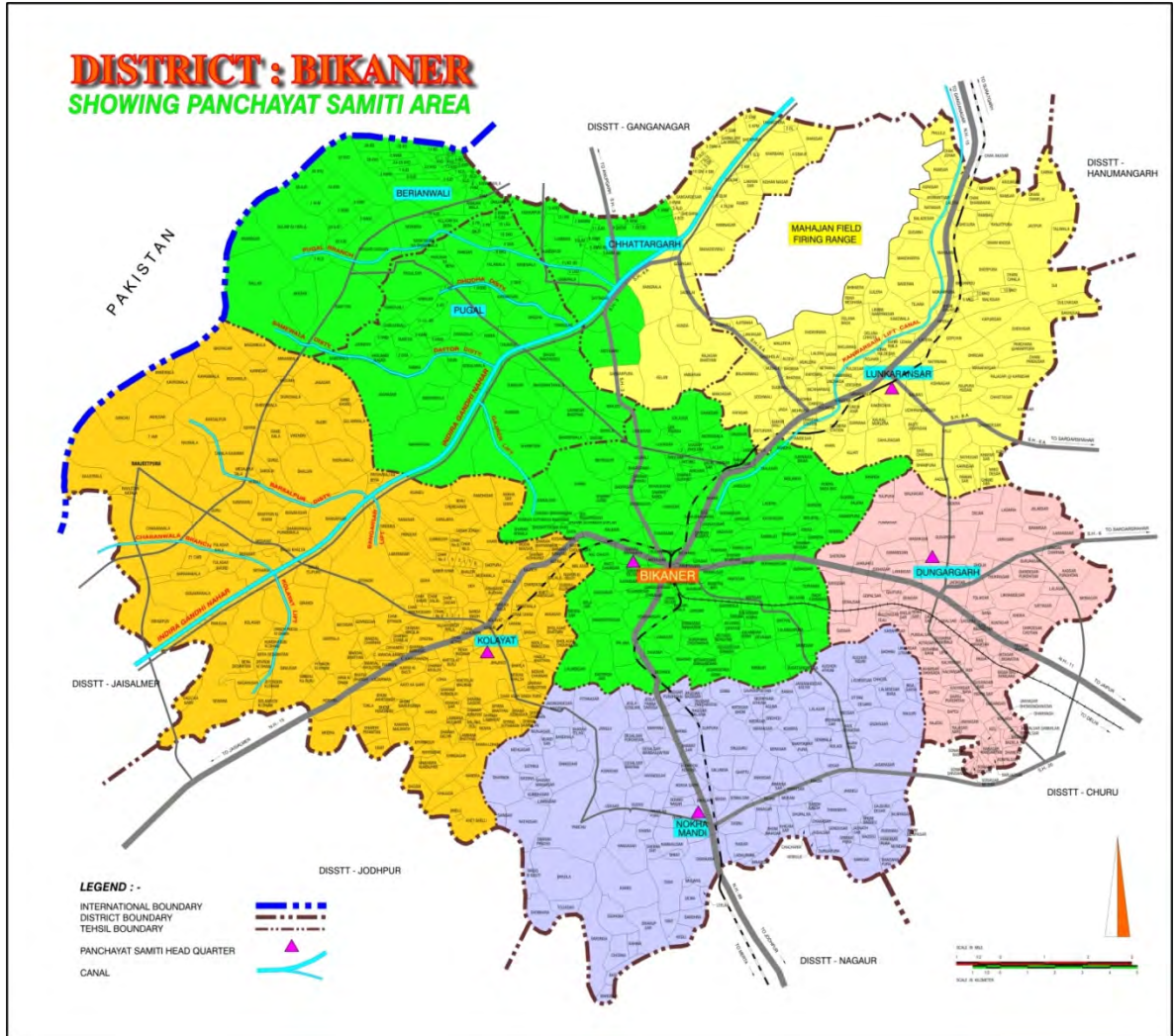

LAND USE/ LAND COVER MAP
WATERSHED - BIKANER - 36 (IWMP)
PANCHAYAT SAMITI - SHRI DUNGARGARH
DISTRICT- BIKANER

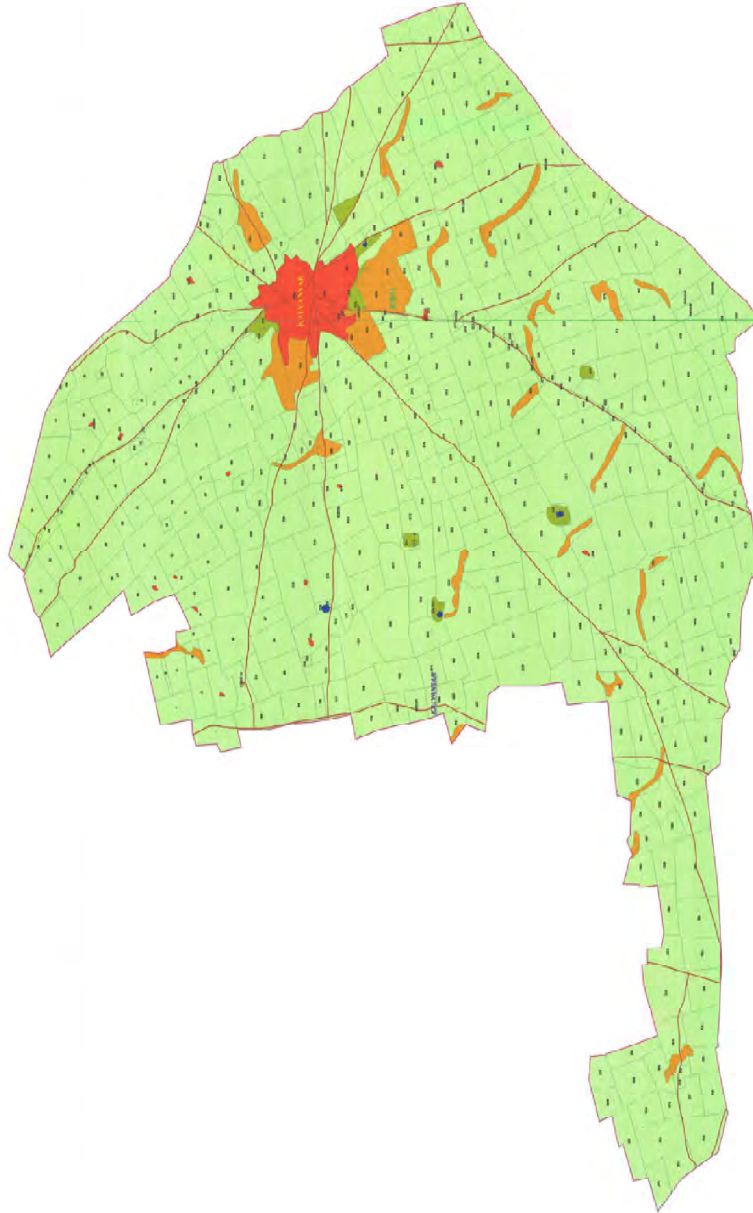

WATERSHED 2011-12
 S.NO. 25

LEGEND	
[Red outline]	WATERSHED BOUNDARY
[Black outline]	VILLAGE BOUNDARY
[Green]	Agroforestry
[Light Green]	Barren/Grass
[Yellow]	Barren/Desert
[Orange]	Barren/Desert
[Blue]	Waterbody
[Red]	Settlement

GEOREFERENCED KHASRA MAP
WATERSHED - BIKANER - 36 (IWMP)
PANCHAYAT SAMITI - SHRI DUNGARGARH
DISTRICT- BIKANER

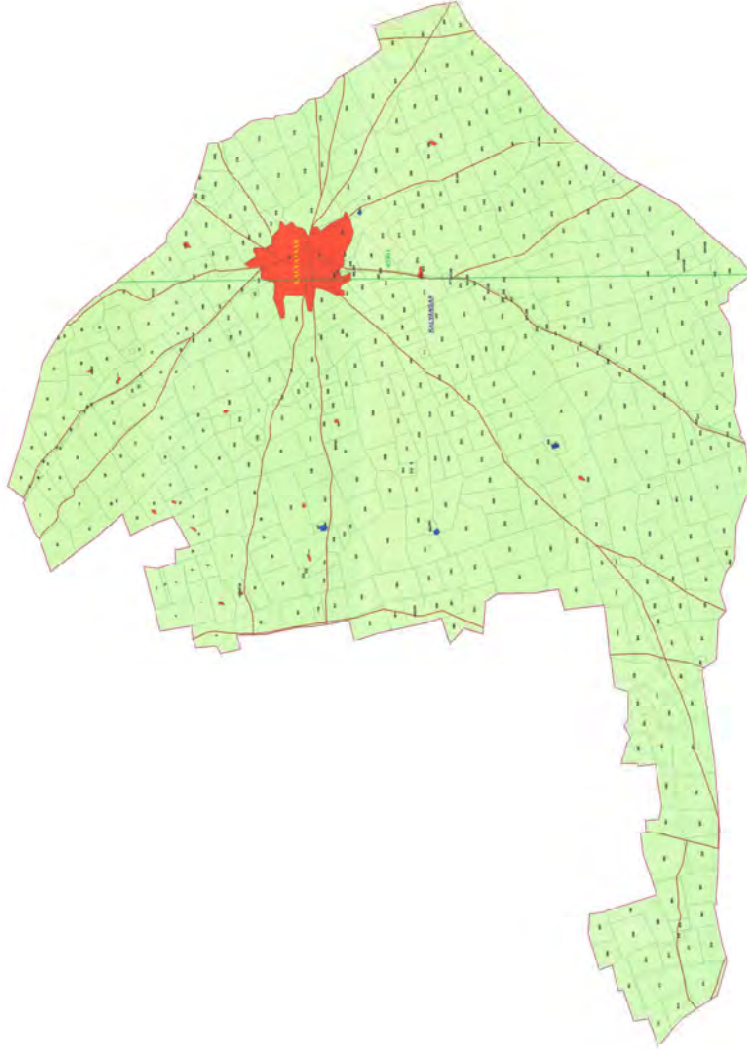

WATERSHED 2011-12
SISO 35

LEGEND	
[Red box]	WATERSHED BOUNDARY
[Green box]	WATERSHED AREA
[Blue box]	WATER BODIES
[Black box]	ROADS
[Red box]	RAILWAYS
[Green box]	WATERWAYS

Institutional arrangements (SLNA,DWDU,PIA,WDT,WC, Secretary) DWDU Details

S.No	Particulars	Details of DWDU
1	PM ,DWDU	Project Manager
2	Address with contact no,website	Executive Engineer (L.R.) Z.P. Bikaner.
3	Telephone	0151-2200695, Mob. 9351201584
4	Fax	0151-2520326 Z. P. Bikaner
5	E-mail	-

PIA particulars

S.No	Particulars	Details of PIA
1	Name of PIA	Mahendra Singh Soora
2	Designation	Assistant Engineer
3	Address with contact no., website	P.S. Sridungargarh.
4	Telephone	01565-222008
5	Fax	01565-222008
6	E-mail	msssoora723@gmail.com

WDT Particulars:

S.No	Name of WDT member	M/F	Age	Qualification	Experience in watershed (Yrs)	Description of professional training	Role/ Function
1	Md.Zahid	M	26	Civil Diploma	1	Engg.	Engineering
2	Om Prakash Delu	M	30	Diploma in AH	-	Veterinary	Veterinary
3						Agri.	Agri.
4.	Sunita Godara	F	28	M.A. (S.S.)	1	Sociology	Sociology

Details of Watershed Committee (WC)

SN	Name of WCs	Date of Gram Sabha for WC	Designation	Name	M/F	Age	SC/ST/ OBC/ General
1.	Watershed Committee, Indpalsar Sankhlan	21-01-2013	President	Mangilal S/o Khumaram	M	45	OBC
			Secretary	Deeparam S/o Bhanwararam	M		OBC
			Member	Rugharam S/o Umaram	M	62	OBC
			Member	Bhagwani Devi W/o Kishnaram	F	45	SC
			Member	Arjan Ram S/o Khumbharam	M	47	OBC
			Member	Govind Singh S/o Balu Singh	M	58	General
			Member	Om Prakash S/o Pemaram	M	25	OBC
			Member	Rameshwarram S/o Bhuraram	M	62	OBC
			Member	Kanaram S/o Himtaram	M	65	OBC
			Member	Lali Devi W/o Kesharam	F	43	SC
			Member	Jaisaram S/o Kumbharam	M	54	OBC
			Member	Kunnaram S/o Malaram	M	33	OBC
			Member	Tulchi Devi W/o Tolaram	F	57	General
			Member	Lichuram S/o Sohanram	M	43	SC

Details of Watershed Committee (WC)

SN	Name of WCs	Date of Gram Sabha for WC	Designation	Name	M/F	Age	SC/ST/ OBC/ General
1.	Watershed Committee, Dharmas	09-10-2012	President	Jagmal Singh	M	60	General
			Secretary	Sitaram Jat	M	26	OBC
			Member	Bishnaram	M	48	SC
			Member	Shyamaram	M	52	SC
			Member	Motiram	M	62	SC
			Member	Kojaram	M	57	SC
			Member	Kamal Kanwar	F	55	General
			Member	Padma Devi	F	62	General
			Member	Tarachand	M	38	General
			Member	Chandrakala	F	37	General
			Member	Sukhveer Singh	M	49	General

Details of Watershed Committee (WC)

SN	Name of WCs	Date of Gram Sabha for WC	Designation	Name	M/F	Age	SC/ST/ OBC/ General
1.	Watershed Committee, Upni	03-10-2012	President	Rampratap S/o Prabhuram	M	50	OBC
			Secretary	Hadmansingh S/o Malaram	M	28	OBC
			Member	Malaram S/o Saluram	M	62	OBC
			Member	Sugnaram S/o Rameshwarlal	M	48	OBC
			Member	Kesuram S/o Khumaram	M	47	OBC
			Member	Sukharam S/o Maluram	M	55	OBC
			Member	Bhanwarlal S/o Motiram	M	54	OBC
			Member	Kishnaram S/o Jetharam	M	50	OBC
			Member	Tolaram S/o Kisturaram	M	58	OBC
			Member	Sharwanram S/o Dularam	M	60	OBC
			Member	Mohini W/o Prabhuram	F	45	OBC
			Member	Aasi W/o Nanuram	F	62	SC
			Member	Chotharam S/o Budharam	M	50	SC
			Member	Malaram S/o Arjanram	M	51	OBC
Member	Rajuram S/o Malaram	M	39	OBC			

Problems and scope of improvement in the project area

The socio economic conditions of the area can be improved through increased production which can be achieved through expansion in cultivated area and productivity enhancement. 2.08 ha. land is arable wasteland and 4.94 ha is fallow can be brought under cultivation. 1104 hac. is only irrigated and with efforts this can be increased to 10-15 % of this area. The productivity gap of major crops in the area as compared with district and with areas in the same agro climatic zones indicate potential to increase the productivity. The demonstration of improved package of practices, improved varieties, increased irrigation facilities and soil conservation measures under the project can bridge this gap. Due to small land holdings in the area focus of the project would be on diversification in agriculture (horticulture, vegetables, green houses, Agro forestry, fodder crops) and diversification in Livelihoods (Agriculture, Animal husbandry, self employment)

50 % fodder scarcity can be met out through Pasture development .Improved animal Husbandry practices can increase the productivity of livestock. 140 no of persons migrate due to unemployment this migration can be checked through creation of employment opportunities in the project area through increase in production and diversification in agriculture and Livelihoods as mentioned above.

Mention specific problem of the area in land degradation, water, Agriculture and in Animal Husbandry

The main problems of the area in land degradation due to Lake of

- 1- Sand dunes stabilisation
- 2- Rain water collection conservation and soil erosion.
- 3- Wind strip cropping.
- 4- Stubble mulching.
- 5- Vegetation.
- 6- Rain water harvesting and its proper use.
- 7- Technical know how of the farmers.

Problem of Live-stock

- 1- Low population of Live-stock and low productivity of their products.
- 2- Unavailability of fodder and drinking water.
- 3- Poverty index % is very low.

I jāp xte ipk; r bhikyI j I kkyku	v/; {k mi I febr ¼yxg.k½ bhikyI j I kkyku	Ljāp xte ipk; r /kekk	v/; {k mi I febr ¼yxg.k½ /kekk	Ljāp xte ipk; r Aih	v/; {k mi I febr ¼yxg.k½ Aih	W.D.T. (Vet.)	W.D.T. (Engg.)	W.D.T. (S.S.)	W.D.T. (Agri.)
--	--	--	---	--	---	--------------------------	---------------------------	--------------------------	---------------------------

CHAPTER – II

Socio economic Features, Problems and Scope

Table 2.1 Population & Household Details:

Total Population					
Gram Panchyat	Male	Female	Total	SC	ST
Indpalsar Sankhlan	1209	1148	2357	375	2
Dharmas	890	703	1593	691	0
Upani	1340	1373	2713	755	0

Household Details							
Gram Panchyat	BPL household	L. Less	Small Farmer	M. Farmer	Total household	SC household	ST household
Indpalsar Sankhlan	119	3	42	15	272	58	0
Dharmas	32	4	40	03	205	130	0
Upani	96	3	81	13	365	150	0

Table 2.2 Development indicators

S. No.	Development Indicators	State	Project Area
1	Per capita income (Rs.)	16260	14500
2	Poverty ratio	0.22	above 70 %
3	Literacy (%)	0.604	54.66, 53.9 %
4	Sex Ratio	903	887, 969
5	infant mortality rate		59 per thousand
6	maternal mortality ratio		388 per Lac.

The table indicates poor socio economic conditions.

Table 2.3 Land Use

Land Use	Total area in Ha.				
	Private	Panchayat	Government	Community	Total
Agriculture Land	6242				6242
Temporary Fallow	331				331
Permanent Fallow	-				
Cultivated Rain fed	4807				4807
Cultivated irrigated	1104				1104
Net Sown Area	5911				5911
Net Area sown more than once	1104				
Forest Land					
Waste Land			140		140
Pastures				67	67
Others			251		251
Total	6242		391	67	6700

The project area has 311 ha of fallow land (total 6700 ha) can be brought under cultivation if some irrigation source can be provided through Construction of WHS like Khadin, Tanka, Farm ponds etc. and also through demonstration of rain fed varieties of crops. Construction of WHS can also increase in area under irrigation which is only 67 ha. non arable and can be brought under vegetative cover, with forestation and Pasture development will be taken up on these lands.

Table 2.4 .a Agriculture and Horticulture status and fuel availability.

Season	Crop Sown	Varieties	Total		
			Area (ha)	Production (ton)	Productivity (kg/ha)
Kharif	Bajra	RHB-121	430	234.35	545
	Moth	RMO-40	967	638.22	660
	Guar	Maru guar	3111	1431.06	460
	G.Nut	TBG-38, 39	299	807	2699
Rabi	Mustard	Pusha Bold	342	446.63	1304
	Gram	RSG-44	298	264.62	888
	Wheat		464	1368.0	2950
Zaid	-				
Total					

All crops are taken in rain fed area

Table 2.4.b Abstract of cropped Area(ha)

Area under Single crop	4807
Area under Double crop	1104
Area under Multiple crop	-

The farmers are using local seed varieties of Gour, Moth, Bajra, G.Nut, Mustard & Gram whereas varieties like maru guar, RMO-40, RHB-121, TBG-39, pusa bold and RSG-44 can increase the production and productivity of this watershed area.

Crop Rotation

- Bajra+moth - Mustard +Gram
- Bajra+guar - Mustard +Gram
- Guar + G.Nut. - Fellow
- Bajra +G.Nut. - Mustard
- Guar - Fellow
- Wheat - Gram

The table 2.4(b) shows that only 1104 ha is double cropped area. Also the crop rotation shows that fallow lands are there. This indicates that there is scope for change in crop rotation in fields where there are fallow lands through Soil and Water conservation measures, crop demonstration and diversification in agriculture.

Soil and Water conservation measures besides putting fallow lands under cultivation can change the area under single cropping to double and multiple cropping

Table 2.4.c Productivity Gap Analysis (The table can also be given in bar chart form)

Name of the crop	Highest Average in Rajasthan Kg//ha	District	Project Area
Gaur	517	460	445
Moth	486	660	600
Bajra	1108	545	540
G. Nut	1966	2699	2705
Wheat	3433	2950	2900
Gram	898	888	888
Mustard	1580	1306	1208

Analysis of the above table indicate that besides national gap there is wide gap in productivity within state and even within same agro climatic zones.

The reasons for this variation are

- The farmers are using local seed varieties of Gour, Moth, Bajra, G.Nut, Mustard & Gram whereas varieties like maru guar, RMO-40, RHB-121, TBG-39, pusa bold and RSG-44 can increase the production and productivity of this watershed area. Lack of Availability of good quality seeds of desired crop and variety in adequate quantities and time to the farmers
- Lack of Availability of good quality seeds of desired crop and variety in adequate quantities and time to the farmers.
- Availability of water for cultivation(1104 is irrigated table 2.3)

The productivity gap and reasons of it indicate potential to increase the productivity through crop demonstration .Crop demonstrations would be carried out on improved crops/ varieties, improved agronomic practices. INM, IPM, Mixed cropping, distribution of fodder seed mini kit. Demonstration of improved methods and economics of fodder crops cultivation and also distribution foundation seeds of Forage Crops for further multiplication, introduction of fodder crops in the existing crop rotations.

Table 2.6 Land holding Pattern in project area

Type of Farmer	Total Households	Land holding (ha) irrigation source wise			Land holding (ha) Social group wise			
		Irrigated (source)	Rain fed	Total	General	SC	ST	OBC
(i) Large farmer	666	1104	4561	5665	1297	1550	0	2820
(ii) Small farmer	163	0	244	244	0	244	0	0
(iii) Marginal farmer	3	0	2.00	2.00	0	2.00	0	0
(iv) Landless	10	0	0	0	0		0	
(v) BPL households							0	
Total	842	1104	4807	5911	1297	1794		2820

19.71 % land holdings belong to small and marginal farmers who own 4.16 % of total cultivated area. Horticulture/vegetables could be more economical to Small and marginal farmers with irrigation source. For large farmers with no irrigation facility Horticulture/vegetables will be promoted in a part of land with farm pond/Tanka construction.

The following activities will be more beneficial for small land holdings and for diversification and income for large farmers.

Horticulture plantation, Medicinal and Aromatic Crops, floriculture- As discussed earlier . Horticulture/vegetables could be more economical to Small and marginal farmers with irrigation source. Also the project area has good potential for medicinal & aromatic crops like Sonamukhi, Isabgol, Ashwagandha, Khus, Mehandi etc.

Agro forestry plantation- To increase the income of farmers and also for shelter belt plantation as wind velocity is high in the project area.

Setting of Vermi Compost Units - Keeping in view the side effect of residues of chemicals and fertilizers on human health the emphasis would be on cultivation of organic produce through motivating farmers and providing assistance for production of organic input, vermi-compost.

Production and distribution of quality seed – There is need to ensure that good quality seed is available for cultivators for which adequate seed production would be initiated in watershed areas with the assistance of private sector and agriculture department technologies

Table 2.7 (A) Livestock Status - animals/milk production / average yield.

S.No.	Description of animals	Population in No.	Yield(milk/mutton/Wool)	Equ. cow units	Dry matter requirement per year (7Kg per animal.)	Total requirement in M.T.
1	Cows					
	Indigenous	910	972 MT	-	2325050 Kg.	23250.05 M.T.
	Crossbred			-	-	
2	Buffaloes	568	762 T	-	1451240 Kg.	1451.24 M.T.
3	Goat	4497	1199.15 T	Popu/2	5744917 Kg.	5744.91 M.T.
4	Sheep	1975	1975 Kg. Wool	Popu/2	2523062 Kg.	2523.06 M.T.
5	Camel	139	-	-	811760 Kg.	811.76 M.T.
6	Poultry		-	-	-	-
7	Piggery		-	-	-	-
	Total	8089			12856029 Kg.	12856.029 M.T.

In spite of the large number of livestock, production is less hence increase in productivity across all species, is a major challenge. To reduce production of unproductive cattle and improve the productivity by improving the breeds by breeding management following activities will be taken up.

- Castration
- Artificial insemination
- Distribution of superior Breeding bulls for use in Cattle and Buffalo
- Breeding distribution crossbred rams

Besides breed improvement other animal husbandry practices like better health, hygiene and feeding practices can increase productivity of livestock. Hence Activities like Animal health camps ,Urea-Molasses treatment demonstration ,demonstration of improved methods of conservation and utilization of Forage crops are proposed.

Table 2.8 Existing area under fodder (ha)

S.No	Item	Unit	Area/Quantity
1	Existing Cultivable area under Fodder	Ha	-
2	Production of Green fodder	Tonns/year	-
3	Production of Dry fodder	Tonns/ Year	-
4	Area under Pastures	Ha	-
5	Production of fodder	Tonns/year	-
6	Existing area under Fuel wood	Ha	-
7	Supplementary feed	Kgs/ day	-
8	Silage Pits	No	-
9	Availability of fodder	quintals	64300.00
10	Deficiency/excess of fodder	quintals	Row 5- total fodder requirement from table2.7

The table above shows there is fodder deficiency (Requirement is 12856.029 MT and availability 6430 MT) To minimize the large and expanding gap between feed and fodder resource availability and demand there is need for

- Increase in area under fodder crops
- Increase in productivity of fodder crops
- Development of pastures
- And reduction in large number of livestock production through replacement by few but productive animals

Table 2.9 Agriculture implements

S. No	Implements	Nos.
1	Tractor	12
2	Sprayers-manual/ power	17
3	Cultivators/Harrows	6
4	Seed drill	1
5	Thresher	1

Farm mechanization and seed banks: As discussed earlier 19.71 % land holdings belong to small and marginal farmers who own only 4.16% of total cultivated area so owning of big farm implements by individual farmers is not economical so SHG would be promoted to buy farm implements and rent to farmer

Table 2.10 NREGA Status - No. of Card Holder, activities taken so far, employment status.

Name of Panchyat	Total No .of job cards	Employment Status	Activity taken up so far
Indpalsar Sankhlan	1682	60%	Earth Work
Dharmas	1285	60%	
Upani	1765	60%	

Table 2.11 Migration Details

Name of village	No. of persons migrating	No. of days per year of migration	Major reason(s) for migrating	Distance of destination of migration from the village (km)	Occupation during migration	Income from such occupation (Rs. in lakh)
Indpalsar	40	90-100	Drought & Lack of Employment	450	labour	60.00 lac
Sankhlan	60					90.00 lac
Dharmas	30					45.00 lac
Upani						

The migration can be check by creation of employment opportunities, enhancing farm level economy, increases the income of the people engaged in animal husbandry by dairy, poultry and marketing and value addition. (As discussed earlier) and diversification in livelihoods .

The existing livelihoods Village are given below

Table 2.12 (a) Major activities (On Farm)

Name of activity	No of House holds	Average annual income from the
cultivators	460	138 lac
Dairying	372	312.48 lac
Landless Agri. Labourers	10	3.50 lac

Table 2.12(b) Major activities (Off Farm)

Name of activity	Households/ individuals	Average annual income from the in Lac.
Artisans	10	16 lac
Carpenter	3	4.5 lac
Blacksmith	1	1.5 lac
Leather Craft	1	2.5 lac
Mason	1	1.50 lac
Others specify (Cycle Repair STD,Craft etc)	1	2.00 lac

The efforts for increase in income through off farm activities will be made under livelihood component through assistance to SHG or individuals

Table 2.13 Status of Existing SHG

S.No	Name of SHG	Members	Monthly income (per mem.)	Fund available	Assistance available	Training received
1	Shanti	10	100	18000	-	-
2.	Kesar	10	100	3000	-	-
3.	Shanti	10	100	10000	-	-
4.	Gusaisar	10	100	1000	-	-
5.	Veer Biggaji	10	100	3600	-	-
6	Bhaatyaniji	10	100	5100	-	-
7	Chotha	10	100	3700	-	-

The table indicates existence of number of groups in the area also these need to be strengthened through trainings and financial assistance

II. Technical Features

Table 2.14 Ground Water

S.No	Source	No.	Functional depth(Ft)	Dry	Area irrigated	Water availability (days)
i)	Dug wells	-	-	-	No.	Cont.
ii)	Shallow tube wells	-	-	-	-	-
iii)	Pumping sets	-	-	-	-	-
iv)	Deep Tube Wells	65	450	-	-	-
	Total	-	-	-	-	-

Table 2.15 Availability of drinking water

Name of the village	Drinking water requirement Ltrs/day	Present availability of drinking water Ltrs/day	No. of drinking water sources available	No. functional	No. requires repairs	No. defunct
Indpalsar Sankhlan Indpalsar Gusaisar Indpalsar Bada Kalyansar Naya	6 Lit	1.20 1.00	PHED	05	05	-

Table 2.16 Slope details.

Slope of Watershed	
Slope percentage	Area in hectares
0 to 3%	6700

As most of the area has slope less than 3% construction of contour bunds can solve the problem of water erosion in agriculture fields and protect washing of top soil and manures/fertilisers

Table 2.17 Soil details

S.No. A	Major Soil Classes	Area in hectares	
1	Sandy	6700	
B	Soil Depth (Cms.)	Area in hectares	
	> 45.00	6700	
C	Soil fertility Status	Kg/ha	Recommended kg/ ha
	N Low	0.17-0.18	100
	P Medium	25.4	60
	K Sufficient	170-180	20
	Micronutrients	PPM	200-300
	Zn	PPM	3
	Fe	PPM	3.5
	Mn	PPM	4.5
	Cu	PPM	4

The analysis of table shows need to improve and maintain soil fertility. Soil health card to every farmer every crop season will be provided, which will include the recommendation for Application micro nutrient and fertilizers.

Table 2.18 Erosion details

Erosion status in project Area			
Type of erosion	Area affected (ha)	Run off (mm/ year)	Average soil loss (Tones/ ha/ year)
Wind erosion	6700	-	13.1%
Total for project	6700	-	13.1%

The need is:

- To check land degradation
- To reduce excessive biotic pressure by containing the number and increase of livestock
- To check cultivation on sloping lands without adequate precautions of soil and water conservation measures
- To discourage cultivation along susceptible mullah beds
- To check Faulty agriculture techniques
- To check Uncontrolled grazing and developed cattle tracks
- To check Deforestation of steep slopes
- To check erosive velocity of runoff, store Runoff, to arrest silt carried by runoff and to recharge Ground Water structures life Earthen check dams, gully plugs, Bank Stabilisation, Loose stone check Dams, Gabions, Earthen embankment (Nadir) and Anicuts would be taken up.

I jāp	v/; {k	Ljāp	v/; {k	Ljāp	v/; {k	W.D.T.	W.D.T.	W.D.T.	W.D.T.
xte	mi I fefr	xte	mi	xte	mi	(Vet.)	(Engg.)	(S.S.)	(Agri.)
ipk; r	½yxg.k½	ipk; r	I fefr	ipk; r	I fefr				
bhikyI j	bhikyI j	/kelk	½yxg.k½	Āiuh	½yxg.k½				
I kkyku	I kkyku		/kelk		Āiuh				



tyxg.k I fefr xBu dsnkjku ppk/djrsgg xke ipk;r Hou /kek'k



i msk fclhqxfrof/k



ih vlg- ,- vli;kl djrsgq jkth xkth lok dthz blhiky l j l kkyku



ty xg.k fodkl ny ds l nl; cš ykž l ošdjrsqg



jkT; Lrjh; d'ld v/; ;u He.k dktjh tkki j ea





jkT; Lrjh; d'ld v/; ;u Hk.k ih ykL=h ty xg.k {k- ea



xkL Lrjh; if'k{k.k dk n';



जिला शिक्षण क्षेत्र में एक दिवसीय ग्राम सभा प्रशिक्षण कार्यक्रम का आयोजन किया गया।



ग्राम सभा प्रशिक्षण कार्यक्रम में महिलाओं को प्रशिक्षण दिया गया।

3 Proposed Development Plan

(The Activities are indicative addition /deletion in activities will be as per local conditions)

A) Preparatory phase activities Capacity Building Trainings and EPA

The IEC activities like Kalajathas, Group meetings, door to door campaign, slogans and wall writings etc. were carried out in all the habitations of Indpalsar Sankhlan, Dharmas, Upani Micro Watershed. A series of meetings were conducted with GP members, community and discussed about the implementation of IWMP programme. User groups were also formed. Gram Sabhas were conducted for approval of EPA (Village), for selecting the watershed committee and approval of DPR.

S.No	Name of the Gram Panchayat	Date on which Grama Sabha approved EPA
1	Indpalsar Sankhlan	21-01-2013
2	Dharmas	09-10-2012
3	Upani	03-10-2012

S. No.	Names of Gram Panchyat	Amount earmarked for EPA	Entry Point Activities planned	Estimated cost	Expenditure incurred	Expected outcome
1	Indpalsar Sankhlan	15.60 lac	GLR Construction, Solar lights, Development work of Shamsan bhumi, Pipeline	15.60 lac	10.00 lac	Village public will happy and trust to our project activity & creation of
2	Dharmas	10.20 lac		10.20 lac	10.20 lac	
3	Upani	14.40 lac		14.40 lac	8.49 lac	

The PRA exercise was carried out in all the villages on the dates shown below:

S.No	Name of the village/Habitation	Date on which PRA conducted
1	Indpalsar Sankhlan	18-04-2013
2	Dharmas	18-04-2013
3	Upani	17-04-2013

Transact walk were carried out involving the community for Social mapping, Resource mapping. Detailed discussions and deliberations with all the primary stakeholders were carried out. Socio-economic survey was carried out during **May-2012 to July-2012** (dates) period covering all the households and primary data on demography, Land holdings, Employment status, Community activities etc. was collected as mentioned in chapter-II.

State remote sensing department was assigned the work of preparing various thematic layers using Cartosat-1 and LISS-3 imageries for Creation, development and

management of geo-spatial database depicting present conditions of land (terrain), water and vegetation with respect to watershed under different ownerships at village level.

Various thematic layers provided by SRSAC are :

- Digitised Khasara maps of the villages falling in project area.
- Base maps (transport network, village/boundaries, and settlements).
- Land Use / Land cover map.

Based on GIS thematic layers, Field visits , PRA and analysis of benchmark data (as discussed in chapter 2) final Treatment plan on revenue map for implementation has been framed. Thus each intervention identified has been marked on revenue map (map enclosed in DPR as annexure 8.1).The GIS based intervention map, PRA based intervention map are annexed as 18.1 e

Critical Assumption

- No severe droughts/ unexpected floods/ natural disasters
- Adequate funds are allocated for the same and released on time.
- There is no significant pest/ disease attack, and if so, then it will have been contained before irreversible damage is done.
- Adverse market conditions do not persist long.
- Sound macro-economic and growth conditions continue and the benefits are widely distributed particularly in the rural areas.
- Facilitating agencies and resource providers have the required competent staff so that timely and appropriate technical advice and services are provided to farmers whenever required.
- The Capacity Building Plan is implemented, monitored and modified to address evolving needs and feedback from participants.
- The execution of the Women's Empowerment Pedagogy is regularly monitored by the District and State level Implementing Agencies

Means of Verification of indicators

- Baseline surveys like household income ,expenditure, health and nutrition etc at the beginning, mid-term and end of the project period
- Annual participatory assessment by communities during project period.
- Regular project monitoring reports prepared by project monitoring teams/ agencies.
- Membership and other Records, Minutes of Meetings maintained by the SHGs, WCs/ Individual beneficiaries/project-related village and local bodies/PRIs.
- External review missions
- Data maintained by Government department (Revenue, Agriculture, Groundwater, Irrigation, Animal Husbandry

Entry Point Activity

IWMP-28 Indpalsar Sankhlan

S. No.	Names of Panchayat	Fund Available for EPA (in Lacs)	EPA Activity	Qty/ No	Estimated cost (in Lacs)	Expenditure (in Lacs)	Expected Outcome
1	Indpalsar Sankhlan	15.60 lac	Construction of GLR with Pipeline	2	5.60	-	Village public will happy and trust to our project activity & creation of
			Development of Shamsan Bhumi (Indpalsar Sakhlan)	1	5.00	5.00	
			Development of Shamsan Bhumi (Indpalsar Gusaisar)	1	5.00	5.00	
					15.60	10.00	

l jãp
xle ipk,r
bhikylj lãkyku

W.D.T.
(Vet.)

v/;{k
mi l fefr ½tyxg.k½
bhikylj lãkyku

A.EN.
(IWMP)
P.S. Sridungargarh

W.D.T.
(Engg.)

W.D.T.
(Social Science.)

ifj;ktuk icU/kd
ftyk tyxg.k fodkl bdkbz
ftyk ifj"n] chdkujA

W.D.T.
(Agri.)

Entry Point Activity

IWMP-28 Dharmas

S. No.	Names of village	Fund Available for EPA (in Lacs)	EPA Activity	Qty/ No	Estimated cost (in Lacs)	Expenditue (in Lacs)	Expected Outcome
1	Dharmas	10.20 Lac	Construction of GLR with Swamion and Lakhora Ki Dhani (With Pipeline)	1	4.20	4.20	Village public will happy and trust to our project activity & creation of
			Construction of GLR with Pipeline (Near Mohanram Jakad House)	1	6.00	6.00	
					10.20	10.20	

l jãp
xte ipk;r
/kelzk

W.D.T.
(Vet.)

v/; {k
mi l febr ½tyxg.k½
/kelzk

A.EN.
(IWMP)
P.S. Sridungargarh

W.D.T.
(Engg.)

W.D.T.
(Social Science.)

ifj; ktuk icl/kd
ftyk tyxg.k fodkl bdkbz
ftyk ifj"n] chdkujA

W.D.T.
(Agri.)

Entry Point Activity

IWMP-28 Upani

S. No.	Names of village	Fund Available for EPA (in Lacs)	EPA Activity	Qty/ No	Estimated cost (in Lacs)	Expenditure (in Lacs)	Expected Outcome
1	Upani	14.40	Construction of GLR with Pipeline (Aam Chowk)	1	2.75	-	Village public will happy and trust to our project activity & creation of
			Development of Shamsan Bhumi (Harijan)	1	8.16	5.00	
			Solar Lights	16	3.49	3.49	
					14.40	8.49	

I jãp
xte ipk;r
Åiuh

W.D.T.
(Vet.)

v/; {k
mi I fefr ½tyxg.k½
Åiuh

A.EN.
(IWMP)
P.S. Sridungargarh

W.D.T.
(Engg.)

W.D.T.
(Social Science.)

W.D.T.
(Agri.)

ifj; ktuk izl/kd
ftyk tyxg.k fodkl bdkbz
ftyk ifj"n] chdkujA

Entry Point Activity

IWMP-28

S. No.	Names	Fund Available for EPA (in Lacs)	EPA Activity	Qty/ No	Estimated cost (in Lacs)	Expenditue (in Lacs)	Expected Outcome
1	IWMP-28	.40.20 Lac	Construction of GLR with Pipeline	5	18.55	10.20	Village public will happy and trust to our project activity & creation of
			Development of Shamsan Bhumi	3	18.16	15.00	
			Solar Lights	16	3.49	3.49	
			Total		40.20	28.69	

W.D.T.
(Engg.)

W.D.T.
(Social Science.)

W.D.T.
(Agri.)

W.D.T.
(Vet.)

A.EN.
(IWMP)
P.S. Sridungargarh

ifj;ktuk izUkd
ftyk tyxg.k fodkl bdkbz
ftyk ifj"m] chdkujA

Component Wise & Year wise Breakup of watershed Activities

Area- 2600 hac. Cost- 0.15 Lac. per hac. Total Cost 390.00 Lac. G.P. Indpalsar Sankhlan

Activity	Year Wise											
	2012-13		2013-14		2014-15		2015-16		2016-17		Total	
	%	Financial	%	Financial	%	Financial	%	Financial	%	Financial	%	Financial
Admn.	1.50	5.85	2.00	7.80	2.50	9.75	2.00	7.80	2.00	7.80	10.00	39.00
Monitoring	0.20	0.78	0.25	0.975	0.25	0.975	0.20	0.78	0.10	0.39	1.00	3.90
Evaluation	0.00	-	0.10	0.39	0.40	1.56	0.00	-	0.50	1.95	1.00	3.90
EPA	4.00	15.60	0.00	-	0.00	-	0.00	-	0.00	-	4.00	15.60
I & CB	1.50	5.85	1.50	5.85	0.50	1.95	1.00	3.90	0.50	1.95	5.00	19.50
DPR	1.00	3.90	0.00	-	0.00	-	0.00	-	0.00	-	1.00	3.90
Watershed Works	0.00	-	20.00	78.00	25.00	97.50	11.00	42.90	0.00	-	56.00	218.40
Production System	0.00	-	2.00	7.80	3.50	13.65	3.50	13.65	1.00	3.90	10.00	39.00
Livelihoods and micro enterprises	0.00	-	1.50	5.85	3.50	13.65	3.50	13.65	0.50	1.95	9.00	35.10
Consolidation	0.00	-	0.00	-	0.00	-	0.00	-	3.00	-	3.00	11.70
Total	0.00	31.98		106.665		139.035		82.68		29.64		390.00

This year wise breakup of watershed activities has been compiled with reference of letter no. F20 (1 - 49) IWMP/fut /2011-12/3843-4137

Dated of 18-07-2012 directorate of Watershed Dev. & Soil Conservation Department Jaipur.

**I jãp
xle ipk;r
bhikylj lklyku**

**W.D.T.
(Vet.)**

**v/; {k
mi l febr ½ tyxg.k
bhikylj lklyku**

**A.EN.
(IWMP)
P.S. Sridungargarh**

**W.D.T.
(Engg.)**

**W.D.T.
(Social Science.)**

**W.D.T.
(Agri.)**

**ifj; kst uk icUkd
ftyk tyxg.k fodkl bdlkz
ftyk ifj"nj chdkujA**

(A) Component Wise & Year wise Breakup of watershed Activities

Natural resources management 56 %

Conservation measures for arable & non-arable land

GP Indpalsar Sankhlan; Village Indpalsar Sankhlan

A) Watershed Development Works	Unit	Qty .	Unit cost (in lac.)	Total Cost (in lac.)	Year										
					2012-13		2013-14		2014-15		2015-16		2016-17		
					Phy	Fin.	Phy.	Fin.	Phy	Fin.	Phy	Fin.	Phy	Fin.	
Construction of Jalkund / Tanka 50000 Lit. Capacity	No	19	2.25	42.75	0	0	3	6.75	11	24.75	5	11.25	0	0	
Construction of Jalkund / Tanka 20000 Lit. Capacity	No	120	1.20	144.00	0	0	43	51.60	51	61.20	26	31.20	0	0	
Sand Dune Stabilization	Ha	06	0.06	0.35	0	0	-	-	3	0.18	3	0.18	0	0	
Total				187.10	0	0		58.35		86.13		42.63	0	0	
B) Conservation measures for non-arable land(Activity)															
Pasture Development	Ha	01	3.40	3.40	0	0	1	3.00	-	0.40	-	-	0	0	
Paki Talai/Nadi	No	01	12.15	12.15	0	0	1	12.15	-	-	-	-	0	0	
Public Jalkund	No	07	2.25	15.75	0	0	2	4.50	5	10.97	-	0.27	0	0	
Sand Dune Stabilization	Ha	-	0.06	-	0	0	-	-	-	-	-	-	0	0	
Total				31.30	0	0		19.65		11.37		0.27	0	0	
Grant total		56 %		218.40	-	-	20%	78.00	25%	97.50	11%	42.90	0	0	

Ljap
xle ipk r
blhikylj l klyku

W.D.T.
(Vet.)

v/;{k
mi l febr
tyxg.k
blhikylj l klyku

A.EN.
(IWMP)
P.S. Sridungargarh

W.D.T.
(Engg.)

W.D.T.
(Social Science.)

W.D.T.
(Agri.)

ifj;ktuk izl/kd
ftyk tyxg.k fodkl bdkbz
ftyk ifj"m] chdkujA

(B) Production System and Livestock**Production measures for arable land Activity (Agriculture) 10% (39 lac.)****GP Indpalsar Sankhlan; Village Indpalsar Sankhlan**

		Unit	Qty	Unit Cost (in lacs)	Total Cost (in lacs)	Year										
						2012-13		2013-14		2014-15		2015-16		2016-17		
						Phy	Fin.	Phy	Fin.	Phy	Fin.	Phy	Fin.	Phy	Fin.	
1	Kitchen Garden (Seed Packet)	No	260	0.005	1.30	0	0	46	0.23	103	0.515	103	0.515	8	0.04	
2	Compost Pit	No	50	0.10	5.00	0	0	2	0.20	24	2.40	24	2.40	0	0	
3	Soil testing	No	650	0.0001	0.065	0	0	130	0.013	250	0.025	250	0.025	20	0.002	
4	Crop Demosstration	Bajara	No	250	0.007	1.75	0	0	50	0.35	90	0.63	90	0.63	20	0.14
		Gaur		250	0.01	2.50	0	0	50	0.50	90	0.90	90	0.90	20	0.20
		Moth		250	0.009	2.25	0	0	50	0.45	90	0.81	90	0.81	20	0.18
		Moong		250	0.01	2.50	0	0	50	0.50	63	0.63	63	0.63	74	0.74
5	Fodder demonstration		No													
		Oat		70	0.006	0.42	0	0	14	0.084	25	0.15	25	0.15	6	0.036
		Barshim		70	0.006	0.42	0	0	14	0.084	25	0.15	25	0.15	6	0.036
		Bajara		70	0.006	0.42	0	0	14	0.084	25	0.15	25	0.15	6	0.036
6	Horticulture plantation for orchard (anar, buded ber)	No	15	0.30	4.5	0	0	5	1.50	4	1.2	4	1.2	2	0.60	
7	Agro forestry along the boundary from of shelter belt distance 10x10 (neem, khejri, desi kikar etc.) for 150 ha area	No	1500	0.0004	0.60	0	0	300	0.12	500	0.20	500	0.20	200	0.08	
8	Agro forestry plantation along the boundary from of shelter belt distance 5x5 (desi ber, ker/kumet etc.)	No	6000	0.0004	2.40	0	0	1200	0.48	2000	0.80	2000	0.80	800	0.32	
9	Horticulture plantion for farm pond 10 plant par pond (karonda, lasova)	No	1500	0.0009	1.35	0	0	300	0.27	500	0.45	500	0.45	200	0.18	
Total									4.865		9.01		9.01		2.59	

Production measures for non arable land Activity (Livestock)
GP Indpalsar Sankhlan; Village Indpalsar Sankhlan

		unit	Qty	Unit cost (in Lac.)	Total Cost (in Lac.)	Year									
						2012-13		2013-14		2014-15		2015-16		2016-17	
						Phy	Fin.	Phy.	Fin.	Phy	Fin.	Phy	Fin.	Phy.	Fin.
1	Veterinary Treatment camp	No	10	0.24	2.40	0	0	2	0.48	3	0.72	3	0.72	2	0.48
2	Vaccination & castration camp	No	10	0.10	1.00	0	0	2	0.20	3	0.30	3	0.30	2	0.20
3	Travis	No	2	0.10	0.20	0	0	2	0.20	0	0	0	0	0	0
4	Manger for improved feeding	No	5	0.015	0.075	0	0	1	0.015	2	0.030	2	0.030	0	0
5	Chaff cutter for making edible fodder														
a	Hand operated (SC/BPL)	No	40	0.02	0.80	0	0	5	0.10	15	0.30	15	0.30	5	0.10
b	Power operated	No	10	0.10	1.00	0	0	2	0.20	3	0.30	3	0.30	2	0.20
6	Male animal distribution for breeding purpose														
a	Cow bull	No	5	0.25	1.25	0	0	1	0.25	2	0.50	2	0.50	0	0
b	Buffalo bull	No	3	0.50	1.50	0	0	1	0.50	1	0.50	1	0.50	0	0
c	Ram	No	30	0.06	1.80	0	0	9	0.54	9	0.54	9	0.54	3	0.18
d	Buck	No	30	0.05	1.50	0	0	9	0.45	9	0.45	9	0.45	3	0.15
7	Infertility camp	No	2	1.00	2.00	0	0	0	0	1	1.00	1	1.00	0	0
	Total				13.525	0	0		2.935		4.64		4.64		1.31
			10%		39.00	0	0	2%	7.80	3.5%	13.65	3.5%	13.65	1%	3.90

I jãp
xte ipk;r
blhikylj l kkyku

W.D.T.
(Vet.)

v/;fk
mi l febr ¼ tyxg.k½
blhikylj l kkyku

A.EN.
(IWMP)
P.S. Sridungargarh

W.D.T.
(Engg.)

W.D.T.
(Social Science.)

W.D.T.
(Agri.)

ifj;ktuk izWkd
ftyk tyxg.k fodkl bdkbz
ftyk ij'n] chdkujA

(C) Livelihood & Micro enterprises

GP Indpalsar Sankhlan; Village Indpalsar Sankhlan

	unit	Qty	Unit cost (in Lac.)	Total Cost (in Lac.)	Year									
					2012-13		2013-14		2014-15		2015-16		2016-17	
					Phy.	Fin.	Phy.	Fin.	Phy.	Fin.	Phy.	Fin.	Phy.	Fin.
Revolving fund to SHGs	No	84	0.25	21.00	0	0	20	5.00	30	7.50	30	7.50	4	1.00
Revolving fund to Individual entrepreneurs	No	14	0.25	3.50	0	0	4	1.00	10	2.5	-	-	-	-
Grant in aid to federation of SHGs	No	06	3.51	10.60	0	0	-	-	01	3.66	02	3.66	2	3.28
Total				35.10	-	-		6.00		13.66		11.16		4.28
Total (B+C)			19 %	74.10				13.80		27.31		24.81		8.18
Total (A+B+C)			75%	292.50				91.80		124.81		67.71		8.18
(D) Consolidation			3%	11.70									3%	11.70
Grand Total			100%	390.00		31.98		106.665		139.035		82.68		29.64

l jãp
xle ipk,r
bñhikylj l kkyku

W.D.T.
(Vet.)

v/;{k
mi l febr
½ tyxg.k
bñhikylj l kkyku

A.EN.
(IWMP)
P.S. Sridungargarh

W.D.T.
(Engg.)

W.D.T.
(Social Science.)

W.D.T.
(Agri.)

ifj;ktuk icU/kd
ftyk tyxg.k fodkl bdkbz
ftyk ifj"m] chdkujA

Component Wise & Year wise Breakup of watershed Activities

Area- 1700 hac. Cost- 0.15 Lac. per hac. Total Cost 255.00 Lac. G.P. Dharmas

Activity	Year Wise											
	2012-13		2013-14		2014-15		2015-16		2016-17		Total	
	%	Financial	%	Financial	%	Financial	%	Financial	%	Financial	%	Financial
Admn.	1.50	3.825	2.00	5.10	2.50	6.375	2.00	5.10	2.00	5.10	10.00	25.50
Monitoring	0.20	0.51	0.25	0.6375	0.25	0.6375	0.20	0.51	0.10	0.255	1.00	2.55
Evaluation	0.00	-	0.10	0.255	0.40	1.02	0.00	-	0.50	1.275	1.00	2.55
EPA	4.00	10.20	0.00	-	0.00	-	0.00	-	0.00	-	4.00	10.20
I & CB	1.50	3.825	1.50	3.825	0.50	1.275	1.00	2.55	0.50	1.275	5.00	12.75
DPR	1.00	2.55	0.00	-	0.00	-	0.00	-	0.00	-	1.00	2.55
Watershed Works	0.00	-	20.00	51.00	25.00	63.75	11.00	28.05	0.00	-	56.00	142.80
Production System	0.00	-	2.00	5.10	3.50	8.925	3.50	8.925	1.00	2.55	10.00	25.50
Livelihoods and micro enterprises	0.00	-	1.50	3.825	3.50	8.925	3.50	8.925	0.50	1.275	9.00	22.95
Consolidation	0.00	-	0.00	-	0.00	-	0.00	-	3.00	7.65	3.00	7.65
Total	0.00	20.91		69.7425		90.9075		54.06		19.38		255.00

This year wise breakup of watershed activities has been compiled with reference of letter no. F20 (1 - 49) IWMP/fut/2011-12/3843-4137

Dated of 18-07-2012 directorate of Watershed Dev. & Soil Conservation Department Jaipur.

**l jãp
xte ipk;r
/kelzk**

**W.D.T.
(Vet.)**

**v/; {k
mi l febr ½tyxg.k½
/kelzk**

**A.EN.
(IWMP)
P.S. Sridungargarh**

**W.D.T.
(Engg.)**

**W.D.T.
(Social Science.)**

**W.D.T.
(Agri.)**

**ifj; ktuk icl/kd
ftyk tyxg.k fodkl bdlbz
ftyk ifj*knj chdkujA**

Component Wise & Year wise Breakup of watershed Activities

Natural resources management 56 %

Conservation measures for arable & non-arable land

GP Dharmas; Village Indpalsar Bada

A) Watershed Development Works	Unit	Qty .	Unit cost (in lac.)	Total Cost (in lac.)	Year									
					2012-13		2013-14		2014-15		2015-16		2016-17	
					Phy	Fin.	Phy.	Fin.	Phy	Fin.	Phy	Fin.	Phy	Fin.
Construction of Jalkund / Tanka 50000 Lit. Capacity	No	08	2.25	18.00	0	0	3	6.75	5	11.25	-	-	0	0
Construction of Jalkund / Tanka 20000 Lit. Capacity	No	77	1.20	92.40	0	0	20	24.00	36	43.20	21	25.20	0	0
Sand Dune Stabilization	Ha	10	0.06	0.60	0	0	5	0.30	3	0.18	2	0.12	0	0
Total				111.00	0	0		31.05		54.63		25.32	0	0
B) Conservation measures for non-arable land(Activity)														
Pasture Development	Ha	01	3.40	3.40	0	0	1	3.18	-	-	-	0.22	0	0
Paki Talai/Nadi	No	01	12.15	12.15	0	0	1	12.15	-	-	-	-	0	0
Public Jalkund	No	07	2.25	15.75	0	0	2	4.50	4	9.00	1	2.25	0	0
Sand Dune Stabilization	Ha	08	0.06	0.50	0	0	2	0.12	2	0.12	4	0.26	0	0
Total				31.80	0	0		19.95		9.12		2.73	0	0
Grant total		56 %		142.80	-	-	20%	51.00	25%	63.75	11%	28.05	0	0

Ljap
xte ipk;r
/kek

W.D.T.
(Vet.)

v/; {k
mi l febr
½ tyxg.k½
/kek

A.EN.
(IWMP)
P.S. Sridungargarh

W.D.T.
(Engg.)

W.D.T.
(Social Science.)

W.D.T.
(Agri.)

ifj; ktuk icl/kd
ftyk tyxg.k fodkl bdkbz
ftyk ifj"n] chdkujA

(B) Production System and Livestock

Production measures for arable land Activity (Agriculture) 10% (25.5 lac.)

GP Dharmas; Village Indpalsar Bada

		Unit	Qty	Unit Cost (in lacs)	Total Cost (in lacs)	Year										
						2012-13		2013-14		2014-15		2015-16		2016-17		
						Phy	Fin.	Phy	Fin.	Phy	Fin.	Phy	Fin.	Phy	Fin.	
1	Kitchen Garden (Seed Packet)	No	215	0.005	1.075	0	0	40	0.20	70	0.35	70	0.35	35	0.175	
2	Compost Pit	No	40	0.10	4.00	0	0	8	0.80	10	1.00	20	2.00	2	0.20	
3	Soil testing	No	500	0.0001	0.05	0	0	100	0.01	150	0.015	150	0.015	100	0.01	
4	Crop Demosstration	Bajara	No	50	0.007	0.35	0	0	10	0.07	15	0.105	15	0.105	10	0.07
		Gaur		50	0.01	0.50	0	0	10	0.10	15	0.15	15	0.15	10	0.10
		Moth		50	0.009	0.45	0	0	10	0.09	15	0.135	15	0.135	10	0.09
		Moong		50	0.01	0.50	0	0	10	0.10	15	0.15	15	0.15	10	0.10
5	Fodder demonstration		No													
		Oat		100	0.006	0.6	0	0	25	0.15	35	0.21	35	0.21	5	0.03
		Barshim		100	0.006	0.6	0	0	25	0.15	35	0.21	35	0.21	5	0.03
		Bajara		100	0.006	0.6	0	0	25	0.15	35	0.21	35	0.21	5	0.03
6	Horticulture plantation for orchard (anar, buded ber)	No	15	0.30	4.5	0	0	3	0.90	5	1.5	5	1.5	2	0.60	
7	Agro forestry along the boundary from of shelter belt distance 10x10 (neem, khejri, desi kikar etc.) for 100 ha area	No	1000	0.0004	0.40	0	0	200	0.08	350	0.14	350	0.14	100	0.04	
8	Agro forestry plantation along the boundary from of shelter belt distance 5x5 (desi ber, ker/kumet etc.)	No	4000	0.0004	1.6	0	0	800	0.32	1400	0.56	1400	0.56	400	0.16	
9	Horticulture plantation for farm pond 10 plant par pond (karonda, lasova)	No	1500	0.0009	1.35	0	0	300	0.27	500	0.45	500	0.45	200	0.18	
Total					16.575				3.39		5.185		6.185		1.815	

Production measures for non arable land Activity (Livestock)

GP Dharmas; Village Indpalsar Bada

		unit	Qty	Unit cost (in Lac.)	Total Cost (in Lac.)	Year									
						2012-13		2013-14		2014-15		2015-16		2016-17	
						Phy	Fin.	Phy.	Fin.	Phy	Fin.	Phy	Fin.	Phy.	Fin.
1	Veterinary Treatment camp	No	6	0.24	1.44	0	0	1	0.24	2	0.48	2	0.48	1	0.25
2	Vaccination & castration camp	No	6	0.10	0.60	0	0	1	0.10	2	0.20	2	0.20	1	0.10
3	Travis	No	1	0.10	0.10	0	0	1	0.10	0	0	0	0	0	0
4	Manger for improved feeding	No	11	0.015	0.165	0	0	2	0.03	4	0.06	4	0.06	1	0.015
5	Chaff cutter for making edible fodder														
a	Hand operated (SC/BPL)	No	36	0.02	0.72	0	0	3	0.06	15	0.30	15	0.30	3	0.06
b	Power operated	No	10	0.10	1.00	0	0	1	0.10	4	0.40	4	0.40	1	0.10
6	Male animal distribution for breeding purpose														
a	Cow bull	No	3	0.25	0.75	0	0	1	0.25	1	0.25	1	0.25	0	0
b	Buffalo bull	No	3	0.50	1.50	0	0	1	0.50	1	0.50	1	0.50	0	0
c	Ram	No	15	0.06	0.90	0	0	3	0.18	5	0.30	5	0.30	2	0.12
d	Buck	No	15	0.05	0.75	0	0	3	0.15	5	0.25	5	0.25	2	0.10
7	Infertility camp	No	1	1.00	1.00	0	0	0	0	1	1.00	0	0	0	0
Total					8.925			1.71		3.74		2.74		0.735	
Total					10%			2%	5.10	3.5%	8.925	3.5%	8.925	1%	2.55

I jãp
xle ipk;r
/kek k

W.D.T.
(Vet.)

v/; {k
mi l febr
½ tyxg.k
/kek k

A.EN.
(IWMP)
P.S. Sridungargarh

W.D.T.
(Engg.)

W.D.T.
(Social Science.)

W.D.T.
(Agri.)

ifj; ktuk icl/kd
ftyk tyxg.k fodkl bdkbz
ftyk ifj"n] chdkujA

(C) Livelihood & Micro enterprises
GP Dharmas; Village Indpalsar Bada

	unit	Qty	Unit cost (in Lac.)	Total Cost (in Lac.)	Year									
					2012-13		2013-14		2014-15		2015-16		2016-17	
					Phy.	Fin.	Phy.	Fin.	Phy.	Fin.	Phy.	Fin.	Phy.	Fin.
Revolving fund to SHGs	No	55	0.25	13.75	0	0	10	2.50	20	5.00	20	5.00	05	1.25
Revolving fund to Individual entrepreneurs	No	09	0.25	2.25	0	0	06	1.50	03	0.75	-	-	-	-
Grant in aid to federation of SHGs	No	04	8.60	6.95	0	0	-	-	1	3.52	1	3.45	-	-
Total				22.95				4.00		9.25		8.45		1.25
Total (B+C)			19 %	48.45	0	0		9.10		18.175		17.375		3.80
Total (A+B+C)			75%	191.25				60.10		81.925		45.425		3.8
(D) Consolidation			3%	7.65									3%	7.65
Grand Total			100%	255.00		20.91		69.7425		90.9075		54.06		19.38

l jãp
xle ipk; r
/kelk

W.D.T.
(Vet.)

v/; {k
mi l febr
½ tyxg.k½
/kelk

A.EN.
(IWMP)
P.S. Sridungargarh

W.D.T.
(Engg.)

W.D.T.
(Social Science.)

W.D.T.
(Agri.)

ifj; ktuk icl/kd
ftyk tyxg.k fodkl bdkbz
ftyk ifj"n] chdkujA

Component Wise & Year wise Breakup of watershed Activities

Area- 2400 hac. Cost- 0.15 Lac. per hac. Total Cost 360.00 Lac. G.P. Upani

Activity	Year Wise											
	2012-13		2013-14		2014-15		2015-16		2016-17		Total	
	%	Financial	%	Financial	%	Financial	%	Financial	%	Financial	%	Financial
Admn.	1.50	5.40	2.00	7.20	2.50	9.00	2.00	7.20	2.00	7.20	10.00	36.00
Monitoring	0.20	0.72	0.25	0.90	0.25	0.90	0.20	0.72	0.10	0.36	1.00	3.60
Evaluation	0.00	-	0.10	0.36	0.40	1.44	0.00	-	0.50	1.80	1.00	3.60
EPA	4.00	14.40	0.00	-	0.00	-	0.00	-	0.00	-	4.00	14.40
I & CB	1.50	5.40	1.50	5.40	0.50	1.80	1.00	3.60	0.50	1.80	5.00	180.00
DPR	1.00	3.60	0.00	-	0.00	-	0.00	-	0.00	-	1.00	3.60
Watershed Works	0.00	-	20.00	72.00	25.00	90.00	11.00	39.60	0.00	-	56.00	201.60
Production System	0.00	-	2.00	7.20	3.50	12.60	3.50	12.60	1.00	3.60	10.00	36.00
Livelihoods and micro enterprises	0.00	-	1.50	5.40	3.50	12.60	3.50	12.60	0.50	1.80	9.00	32.40
Consolidation	0.00	-	0.00	-	0.00	-	0.00	-	3.00	10.80	3.00	10.80
Total	0.00	29.52	0	98.46	0	128.34		76.32		27.36		360.00

This year wise breakup of watershed activities has been compiled with reference of letter no. F20 (1 - 49) IWMP/fut^{Hk}/2011-12/3843-4137

Dated of 18-07-2012 directorate of Watershed Dev. & Soil Conservation Department Jaipur.

**l jãp
xte ipk;r
Åiuh**

**W.D.T.
(Vet.)**

**v/;{k
mi l febr ¼tyxg.k½
Åiuh**

**A.EN.
(IWMP)
P.S. Sridungargarh**

**W.D.T.
(Engg.)**

**W.D.T.
(Social Science.)**

**W.D.T.
(Agri.)**

**ifj;ktuk iclWkd
ftyk tyxg.k fodkl bdlbZ
ftyk ifj*lnj chdkujA**

Component Wise & Year wise Breakup of watershed Activities

Natural resources management 56 %

Conservation measures for arable & non-arable land

GP Upani; Village Kalyansar Naya

A) Watershed Development Works	Unit	Qty .	Unit cost (in lac.)	Total Cost (in lac.)	Year									
					2012-13		2013-14		2014-15		2015-16		2016-17	
					Phy	Fin.	Phy.	Fin.	Phy	Fin.	Phy	Fin.	Phy	Fin.
Construction of Jalkund / Tanka 50000 Lit. Capacity	No	20	2.25	45.00	0	0	02	4.50	10	22.50	08	18.00	0	0
Construction of Jalkund / Tanka 20000 Lit. Capacity	No	104	1.20	124.80	0	0	38	45.60	48	57.60	18	21.60	0	0
Sand Dune Stabilization	Ha	05	0.06	0.30	0	0	-	-	05	0.30	-	-	0	0
Total				170.10	0	0		50.10		80.40	-	-	0	0
B) Conservation measures for non-arable land(Activity)														
Pasture Development	Ha	01	3.40	3.40	0	0	01	3.00	-	0.40	-	-	0	0
Paki Talai/Nadi	No	01	12.15	12.15	0	0	01	12.15	-		-	-	0	0
Public Jalkund	No	07	2.25	15.75	0	0	03	6.75	04	9.00	-	-	0	0
Sand Dune Stabilization	Ha	03	0.06	0.20	0	0	-	-	03	0.20	-	-	0	0
Total				31.50	0	0		21.90		9.60	-	-	0	0
Grant total		56 %		201.60	-	-	20%	72.00	25%	90.00	11%	39.60	0	0

Ljãp
xle ipk;r
Åiuh

W.D.T.
(Vet.)

v/; {k
mi l febr
½ tyxg.k½
Åiuh

A.EN.
(IWMP)
P.S. Sridungargarh

W.D.T.
(Engg.)

W.D.T.
(Social Science.)

W.D.T.
(Agri.)

ifj;ktuk icl/kd
ftyk tyxg.k fodkl bdkbz
ftyk ifj"n] chdkujA

(B) Production System and Livestock

Production measures for arable land Activity (Agriculture) 10% (36 lac.)

GP Upani; Village Kalyansar Naya

		Unit	Qty	Unit Cost (in lacs)	Total Cost (in lacs)	Year									
						2012-13		2013-14		2014-15		2015-16		2016-17	
						Phy	Fin.	Phy	Fin.	Phy	Fin.	Phy	Fin.	Phy	Fin.
1	Kitchen Garden (Seed Packet)	No	145	0.005	0.725	0	0	17	0.085	60	0.30	60	0.30	8	0.04
2	Compost Pit	No	50	0.10	5.00	0	0	9	0.90	18	1.80	18	1.80	5	0.50
3	Soil testing	No	650	0.0001	0.065	0	0	30	0.003	310	0.031	310	0.031	0	0
4	Crop Demosstration	Bajara	250	0.007	1.75	0	0	50	0.35	70	0.49	70	0.49	60	0.42
		Gaur	250	0.01	2.50	0	0	50	0.50	70	0.70	70	0.70	60	0.60
		Moth	250	0.009	2.25	0	0	50	0.45	80	0.72	80	0.72	40	0.36
		Moong	250	0.01	2.50	0	0	50	0.50	70	0.70	70	0.70	60	0.60
5	Fodder demonstration														
		Oat	70	0.006	0.42	0	0	14	0.084	28	0.168	28	0.168	0	0
		Barshim	70	0.006	0.42	0	0	14	0.084	28	0.168	28	0.168	0	0
		Bajara	70	0.006	0.42	0	0	14	0.084	28	0.168	28	0.168	0	0
6	Horticulture plantation for orchard (anar, buded ber)	No	10	0.30	3.00	0	0	2	0.60	4	1.2	4	1.2	0	0
7	Agro forestry along the boundary from of shelter belt distance 10x10 (neem, khejri, desi kikar etc.) for 100 ha area	No	1500	0.0004	0.60	0	0	300	0.12	600	0.24	600	0.24	0	0
8	Agro forestry plantation along the boundary from of shelter belt distance 5x5 (desi ber, ker/kumet etc.)	No	6000	0.0004	2.40	0	0	1200	0.48	2400	0.96	2400	0.96	0	0
9	Horticulture plantation for farm pond 10 plant par pond (karonda, lasova)	No	1500	0.0009	1.35	0	0	300	0.27	600	0.54	600	0.54	0	0
Total								4.51		8.185		8.185		2.52	

Production measures for non arable land Activity (Livestock)

GP Upani; Village Kalyansar Naya

		unit	Qty	Unit cost (in Lac.)	Total Cost (in Lac.)	Year										
						2012-13		2013-14		2014-15		2015-16		2016-17		
						Phy	Fin.	Phy.	Fin.	Phy	Fin.	Phy	Fin.	Phy.	Fin.	
1	Veterinary Treatment camp	No	10	0.24	2.40	0	0	2	0.48	3	0.72	3	0.72	2	0.48	
2	Vaccination & castration camp	No	10	0.10	1.00	0	0	2	0.20	3	0.30	3	0.30	2	0.20	
3	Travis	No	1	0.10	0.10	0	0	1	0.10	0	0	0	0	0	0	
4	Manger for improved feeding	No	10	0.015	0.15	0	0	2	0.03	3	0.045	3	0.045	2	0.30	
5	Chaff cutter for making edible fodder															
a	Hand operated (SC/BPL)	No	20	0.02	0.40	0	0	2	0.04	8	0.16	8	0.16	2	0.04	
b	Power operated	No	5	0.10	0.50	0	0	1	0.10	2	0.20	2	0.20	0	0	
6	Male animal distribution for breeding purpose															
a	Cow bull	No	5	0.25	1.25	0	0	1	0.25	2	0.50	2	0.50	0	0	
b	Buffalo bull	No	3	0.50	1.50	0	0	1	0.50	1	0.50	1	0.50	0	0	
c	Ram	No	30	0.06	1.80	0	0	9	0.54	9	0.54	9	0.54	3	0.18	
d	Buck	No	30	0.05	1.50	0	0	9	0.45	9	0.45	9	0.45	3	0.15	
7	Infertility camp	No	2	1.00	2.00	0	0	0	0	1	1.00	1	1.00	0	0	
Total					12.60	0	0		2.69		4.415		4.415		1.08	
				10%	36.00				2%	7.20	3.5%	12.60	3.5%	12.60	1%	3.60

**I jãp
xã ipk;r
Aih**

W.D.T.
(Vet.)

**v/; {k
mi l febr
½ tyxg.k½
Aih**

A.EN.
(IWMP)
P.S. Sridungargarh

W.D.T.
(Engg.)

W.D.T.
(Social Science.)

W.D.T.
(Agri.)

**ifj; ktuk izWkd
ftyk tyxg.k fodkl bdkbz
ftyk ifj"n] chdkujA**

(C) Livelihood & Micro enterprises
GP Upani; Village Kalyansar Naya

	unit	Qty	Unit cost (in Lac.)	Total Cost (in Lac.)	Year									
					2012-13		2013-14		2014-15		2015-16		2016-17	
					Phy.	Fin.	Phy.	Fin.	Phy.	Fin.	Phy.	Fin.	Phy.	Fin.
Revolving fund to SHGs	No	79	0.25	19.75	0	0	10	2.50	30	7.50	31	7.75	8	2.00
Revolving fund to Individual entrepreneurs	No	14	0.25	3.50	0	0	12	3.00	01	0.25	1	0.25	-	-
Grant in aid to federation of SHGs	No	5	-	9.15	0	0		-	02	3.66	2	3.66	1	1.83
Total				32.40	-	-		5.50		11.41		11.66		3.83
Total (B+C)			19 %	68.4	0	0		12.70		24.01		24.26		7.43
Total (A+B+C)			75%	270.				84.70		114.01		63.86		7.43
(D) Consolidation			3%	10.80									3%	10.80
Grand Total			100%	360.00		29.52		98.46		128.34		76.32		27.36

l jãp
xle ipk;r
Aíuh

W.D.T.
(Vet.)

v/; {k
mi l febr
½ tyxg.k½
Aíuh

A.EN.
(IWMP)
P.S. Sridungargarh

W.D.T.
(Engg.)

W.D.T.
(Social Science.)

W.D.T.
(Agri.)

ifj; ktuk icl/kd
ftyk tyxg.k fodkl bdkbz
ftyk ifj"n] chdkujA

Component Wise & Year wise Breakup of watershed Activities

Area- 6700 hac. Cost- 0.15 Lac. per hac. Total Cost 1005.00 Lac. IWMP-28

Activity	Year Wise											
	2012-13		2013-14		2014-15		2015-16		2016-17		Total	
	%	Financial	%	Financial	%	Financial	%	Financial	%	Financial	%	Financial
Admn.	1.50	15.075	2.00	20.10	2.50	25.125	2.00	20.10	2.00	20.10	10.00	100.50
Monitoring	0.20	2.01	0.25	2.5125	0.25	2.5125	0.20	2.01	0.10	1.005	1.00	10.05
Evaluation	0.00	-	0.10	1.005	0.40	4.02	0.00	-	0.50	5.025	1.00	10.05
EPA	4.00	40.20	0.00	-	0.00	-	0.00	-	0.00	-	4.00	40.20
I & CB	1.50	15.075	1.50	15.075	0.50	5.025	1.00	10.05	0.50	5.025	5.00	50.25
DPR	1.00	10.05	0.00	-	0.00	-	0.00	-	0.00	-	1.00	10.05
Watershed Works	0.00	-	20.00	201.00	25.00	251.25	11.00	110.55	0.00	-	56.00	562.80
Production System	0.00	-	2.00	20.10	3.50	35.175	3.50	35.175	1.00	10.05	10.00	100.50
Livelihoods and micro enterprises	0.00	-	1.50	15.075	3.50	35.175	3.50	35.175	0.50	5.025	9.00	90.45
Consolidation	0.00	-	0.00	-	0.00	-	0.00	-	3.00	30.15	3.00	30.15
Total	0.00	82.41		274.8675		358.2825		213.06		76.38		1005.00

This year wise breakup of watershed activities has been compiled with reference of letter no. F20 (1 - 49) IWMP/ftHk /2011-12/3843-4137

Dated of 18-07-2012 directorate of Watershed Dev. & Soil Conservation Department Jaipur.

W.D.T.
(Engg.)

W.D.T.
(Social Science.)

W.D.T.
(Agri.)

W.D.T.
(Vet.)

A.EN.
(IWMP)
P.S. Sridungargarh

ifj;ktuk izl/kd
ftyk tyxg.k fodkl bdlbz
ftyk ifj*knj chdkujA

Component Wise & Year wise Breakup of watershed Activities

Natural resources management 56 %

Conservation measures for arable & non-arable land

IWMP-28

A) Watershed Development Works	Unit	Qty .	Unit cost (in lac.)	Total Cost (in lac.)	Year							
					2012-13		2013-14		2014-15		2015-16	
					Phy	Fin.	Phy.	Fin.	Phy	Fin.	Phy	Fin.
Construction of Jalkund / Tanka 50000 Lit. Capacity	No	47	2.25	105.75	0	0	8	18.0	26	58.50	13	29.25
Construction of Jalkund / Tanka 20000 Lit. Capacity	No	301	1.20	361.20	0	0	101	121.20	135	162.00	65	78.00
Sand Dune Stabilization	Ha	21	0.06	1.25	0	0	5	0.30	11	0.66	5	0.30
Total				468.20	0	0		139.50		221.16		107.55
B) Conservation measures for non-arable land(Activity)												
Pasture Development	Ha	3	3.40	10.20	0	0	3	9.18	-	0.80	-	0.22
Paki Talai/Nadi	No	3	12.15	36.45	0	0	3	36.45	-	-	-	-
Public Jalkund	No	21	2.25	47.25	0	0	7	15.75	13	28.97	1	2.25
Sand Dune Stabilization	Ha	11	0.06	0.70	0	0	2	0.12	5	0.30	4	0.23
Total				94.60	0	0		61.50		30.07		2.70
Grant total		56 %		562.80	-	-	20%	201.00	25%	251.25	11%	110.55

W.D.T.
(Engg.)

W.D.T.
(Social Science.)

W.D.T.
(Agri.)

W.D.T.
(Vet.)

A.EN.
(IWMP)
P.S. Sridungargarh

ifj;ktuk izl/kd
ftyk tyxg.k fodkl bdkbz
ftyk ifj"m] chdkujA

B) Production System and Livestock

Production measures for arable land Activity (Agriculture) 10% (100.5 lac.)

IWMP-28

		Unit	Qty	Unit Cost (in lacs)	Total Cost (in lacs)	Year										
						2012-13		2013-14		2014-15		2015-16		2016-17		
						Phy	Fin.	Phy	Fin.	Phy	Fin.	Phy	Fin.	Phy	Fin.	
1	Kitchen Garden (Seed Packet)	No	620	0.005	3.10	0	0	103	0.515	233	1.165	233	1.165	51	0.255	
2	Compost Pit	No	140	0.10	14.00	0	0	19	1.90	52	5.20	62	6.20	7	0.70	
3	Soil testing	No	1800	0.0001	0.180	0	0	260	0.026	710	0.071	710	0.071	120	0.012	
4	Crop Demosstration	Bajara	No	550	0.007	3.85	0	0	110	0.77	175	1.225	175	1.225	90	0.63
		Gaur		550	0.01	5.50	0	0	110	1.10	175	1.75	175	1.75	90	0.90
		Moth		550	0.009	4.95	0	0	110	0.99	185	1.665	185	1.665	70	0.63
		Moong		550	0.01	5.50	0	0	110	1.10	148	1.48	148	1.48	144	1.44
5	Fodder demonstration		No													
		Oat		240	0.006	1.44	0	0	53	0.318	88	0.528	88	0.528	11	0.066
		Barshim		240	0.006	1.44	0	0	53	0.318	88	0.528	88	0.528	11	0.066
		Bajara		240	0.006	1.44	0	0	53	0.318	88	0.528	88	0.528	11	0.066
6	Horticulture plantation for orchard (anar, buded ber)	No	40	0.30	12.00	0	0	10	3.00	13	3.9	13	3.9	4	1.20	
7	Agro forestry along the boundary from of shelter belt distance 10x10 (neem, khejri, desi kikar etc.) for 100 ha area	No	4000	0.0004	1.60	0	0	800	0.32	1450	0.58	1450	0.58	300	0.12	
8	Agro forestry plantation along the boundary from of shelter belt distance 5x5 (desi ber, ker/kumet etc.)	No	16000	0.0004	6.40	0	0	3200	1.28	5800	2.32	5800	2.32	1200	0.48	
9	Horticulture plantion for farm pond 10 plant par pond (karonda, lasova)	No	4500	0.0009	4.05	0	0	900	0.81	1600	1.44	1600	1.44	400	0.36	
Total					65.45				12.765		22.38		23.38		6.925	

Production measures for non arable land Activity (Livestock)

IWMP-28

		unit	Qty	Unit cost (in Lac.)	Total Cost (in Lac.)	Year									
						2012-13		2013-14		2014-15		2015-16		2016-17	
						Phy	Fin.	Phy.	Fin.	Phy	Fin.	Phy	Fin.	Phy.	Fin.
1	Veterinary Treatment camp	No	26	0.24	6.24	0	0	5	1.20	8	1.92	8	1.92	5	1.20
2	Vaccination & castration camp	No	26	0.10	2.60	0	0	5	0.50	8	0.80	8	0.80	5	0.50
3	Travis	No	4	0.10	0.40	0	0	4	0.40	0	0	0	0	0	0
4	Manger for improved feeding	No	26	0.015	0.39	0	0	5	0.075	9	0.135	9	0.135	3	0.045
5	Chaff cutter for making edible fodder														
a	Hand operated (SC/BPL)	No	96	0.02	1.92	0	0	10	0.20	38	0.76	38	0.76	10	0.20
b	Power operated	No	25	0.10	2.50	0	0	4	0.40	9	0.90	9	0.90	3	0.30
6	Male animal distribution for breeding purpose														
a	Cow bull	No	13	0.25	3.25	0	0	3	0.75	5	1.25	5	1.25	0	0
b	Buffalo bull	No	9	0.50	4.50	0	0	3	1.50	3	1.50	3	1.50	0	0
c	Ram	No	75	0.06	4.50	0	0	21	1.26	23	1.38	23	1.38	8	0.48
d	Buck	No	75	0.05	3.75	0	0	21	1.05	23	1.15	23	1.15	8	0.40
7	Infertility camp	No	5	1.00	5.00	0	0	0	0	3	3.00	2	2.00	0	0
	Total				35.05	0	0		7.335		12.795		11.795		3.125
				10%	100.50	0	0	2%	20.10	3.5%	35.175	3.5%	35.175	1%	10.05

W.D.T.
(Engg.)

W.D.T.
(Social Science.)

W.D.T.
(Agri.)

W.D.T.
(Vet.)

A.EN.
(IWMP)
P.S. Sridungargarh

ifj;ktuk icl/kd
ftyk tyxg.k fodkl bdkbz
ftyk ifj"n] chdkujA

(C) Livelihood & Micro enterprises
IWMP-28

	unit	Qty	Unit cost (in Lac.)	Total Cost (in Lac.)	Year									
					2012-13		2013-14		2014-15		2015-16		2016-17	
					Phy.	Fin.	Phy.	Fin.	Phy.	Fin.	Phy.	Fin.	Phy.	Fin.
Revolving fund to SHGs	No	218	0.25	54.50	0	0	40	10.00	80	20.00	81	20.25	17	4.25
Revolving fund to Individual entrepreneurs	No	37	0.25	9.25	0	0	22	5.50	14	3.50	1	0.25	-	-
Grant in aid to federation of SHGs	No	15	-	26.70	0	0	-	-		10.82		10.77		5.11
Total				90.45	-	-		15.50		34.32		31.27		9.36
Total (B+C)			19 %	190.95				35.60		69.495		66.445		19.41
Total (A+B+C)			75%	753.75				236.60		320.745		176.995		15.075
(D) Consolidation			3%	30.15									3%	30.15
Grand Total			100%	1005.00		82.41		274.8675		358.2825		213.06		76.38

W.D.T.
(Engg.)

W.D.T.
(Social Science.)

W.D.T.
(Agri.)

W.D.T.
(Vet.)

A.EN.
(IWMP)
P.S. Sridungargarh

ifj; ktuk izUkd
ftyk tyxg.k fodkl bdkbz
ftyk ifj"n] chdkujA

EXPECTED OUT COMES

1	2		3	4	5	6
S. No.	Item		Unit of measurement	Pre-project Status	Expected Post-project Status	Remarks
1	Quality of drinking water		Description	Salty + Normal	good	-
2	Availability of drinking water		Description	Sufficient	Sufficient	-
3	Change in irrigated Area		Ha	0	20-25 hac.	-
4	Change in cropping/ land use pattern		Description	Guar	Guar + Horticulture crop	-
5	Area under agricultural crop					-
6	I	Area under single crop	Ha	4807	4205	-
7	II	Area under double crop	Ha	1104	1315	-
8	III	Area under multiple crop	Ha	0	0	--
	Change in cultivated Area		Ha	0	10-15 %	-
9 yield of major crops of area	Yield of Guar		q/ha	2.0-2.5	4.0-4.5	-
	Yield of Moth		q/ha	2.0-2.5	3-3.5	-
	Yield of Gram		q/ha	0	0	-
	Yield of Mustard		q/ha	0	0	-
10 production of major crops of area	Production of Guar		ton	57	77	-
	Production of Moth		ton	0.3	1	-
	Production of Gram		ton	0	0	
	Production of Mustard		ton	0	0	
11	Area under vegetation		Ha	0	6	Kitchen gardening

1	2	3	4	5	6
S. No.	Item	Unit of measurement	Pre-project Status	Expected Post-project Status	Remarks
12	Area under horticulture	Ha	0	10	Bare Plantation
13	Area under fuel	Ha	0	39	by Plantation of orestrary
14	Area under Fodder	Ha	0	38	by Pasture dev.
15	Fodder production	Q	0	45	-
16	Milk production	Litres/day	4	9	-
17	SHGs Active	No.	2	12	-
18	No. of livelihoods	No.	0	25	-
19	Income	Rs.in la	6.3	8.5	-
20	Migration	No.	140	50	-
21	SHG Federations formed	No.	0	7	-

eMj rdehuk tydqM@Vlak (w.H.S.) 20]000 yMj {kerk

SN	dk; lfooj .k	ek=k	bdkbz	nj		jfk'k dy
				Je	dy	
1	uhø] [kkbz ijuky es 1-5 ehVj xgkjkbz rd feVVh dh [kpkbz djuk ry dks dWuk] ikuh Mkyuk] cxy dks l okjuk] [kph gøz feVVh dks ckgj fudkyuk] uhoa Hkjus ds ckn [kkyh djuk] LFkkuks dks i p% feVVh l s Hkjuk rFkk cph gøz feVVh dks 50 ehVj dh njh rd fuLrkj .k djuk					
v	l k/kj .k eyk; e feVVh ea vkøjcMzu mBkuk 13*13*0.30	50.70	?k-eh	76-00	76-00	3853-00
c	l [r fpduh dædj feVVh ea 1-5 eh rd $\pi/4*(3.80)2*1.50$	17.00	?k-eh	93-00	93-00	1581-00
l	1-5 eh l smij [kpkbz $\pi/4*(3.80)2*1.80$	20.40	?k-eh	103-80	103-80	2117-00
2	l heVV dæfjV uhoa ; k Q'kz es 40 feeh ukkh; eki dh iRFkj fxVVh l heVV jr el kyk , d l heVV& 4 jr 8 fxVVh ds vui kr esfeykdj Mkyuk rFkk dW/kbz djuk o rjkbz djuk					
	$\pi/4*(3.50)2*0.3$	2.88	?k-eh		2222-00	6399-00
3	uhoarFkk dæ lz es i Fke Jskh dh bæ/ks dh pøkbz l heVV ctjh 1% ese; cxy dh f>jh cln djuk		?k-eh			
	mij dh nhokj $\pi/4*[(3.75)2-(3.05)2]*0.60$	2.24	?k-eh			
	tydqM $\pi/4*[(3.5)2-(3.05)2]*3.00$	6.94	?k-eh			
	ik; ru nhokj $\pi*10.23* 2.3*0.75$	5.54	?k-eh			
	dy dk; l	14.72	?k-eh		3050-00	44896-00
4	iRFkj dsfl jny fyWj 7-5 l seh- ek/kbz dh vki firz dj fpukbz ea mi ; ks dh xbz el kys ea ml s yxkuk					
	$2*3.50*0.30$	2.10	o-eh		683-00	1434-00

SN	dk; Zfooj .k	ek=k	bdkbz	nj		jkr'k dy
				Je	dy	
5	voy ntldh iRFkj dh ifV; ka dh Nr Mkyuk Ajj rFk fups l s tkM/s es iRFkj dh phi ds l kfk 1% vujkr es l heV el kyk l s Hkjuk ¼ 2 l s 2-5 ehVj Liku½ ftl ea 100, e-, e- ek/kbz dk bM/ka dk [kMatk 'kkfey g/s	11.03				
	$\pi/4*(3.75)^2$	11.03				
	?kVkbz s	0.20				
	dy dk; Z	10.83	o-eh		1366-00	14793-00
7-	ik; ru ea /kkkyk ejje Mkyuk rFk njeV l s dly/kbz djuk rjkbz l er					
	$\pi/4*(10.00^2-3.50^2)*0.10$	6.88	?k- eh		287-00	1974-00
8	50 eh-eh ek/kbz ea l h-da 1%2% feJ.k ftl ea 1 l heV] 2 ctjh 4 iRFkj dh fxVVh feykdj Mkyuk dWuk rjkbz l er					
	$\pi/4*(10.00)^2$ $-(0.45*0.45)$	78.30	o-eh		253-00	19809-00
9-	l heV lykLVj nhokj ij 1% vujkr ea l heV ctjh feykdj tkM/ka dks djn n/s rFk rjkbz l fgr 20 eh-eh					
	ink $\pi/4*(3.05)^2$	7.30	o-eh			
	vlnj $\pi*3.05*3.60$	34.47	o-eh			
	ckgh nhokj $\pi*3.75*0.60$	7.06	o-eh			
		48.53			127-00	6201-00
10	20 , e-, e- ek/kbz dk l heV lykLVj l heV ctjh el kyk 1% ea					
	Nr o ik; ru $\pi/4*(10.00)^2$	78.50	o-eh			
	ik; ru nhokj $\pi*10.23*1.08$	34.69	o-eh			
	?kV; 8 0.45*0.45	0.20	o-eh			
	dy dk; Z	112.99	o-eh		113-00	12767-00
10-	dqM dk xV fQfVx l fgr	1	1		700-00	700-00
11-	i hoh-l h- i kbi 75 eh-eh 0; kl	6	eh		120-00	720-00
12-	QkV/s o ckMz					500-00
					; kx	117744-00
					2 ifr'kr dUVht@l h@VBMj fMQj@l	2354-00
						120098

Say Rs. 1.20 Lac.

njaf tyk ifj'kn %keh.k fodkl izdks B½ chdkuj dh ch, l -vkj- 01-04-13 , oaou foHkx dh ch, l -vkj ds vuq kj g@

Ijap
xte ipk; r
bhikylj
l kkyku

v/; {k
mi l febr
¼yxg.½
bhikylj
l kkyku

Ljap
xte
ipk; r
/kelk

v/; {k
mi l febr
¼yxg.½
/kelk

Ljap
xte
ipk; r
Aiuh

v/; {k
mi l febr
¼yxg.½
Aiuh

W.D.T.
(Engg.)

JALKUND/Tanka
CAPACITY 22,300 LTR.

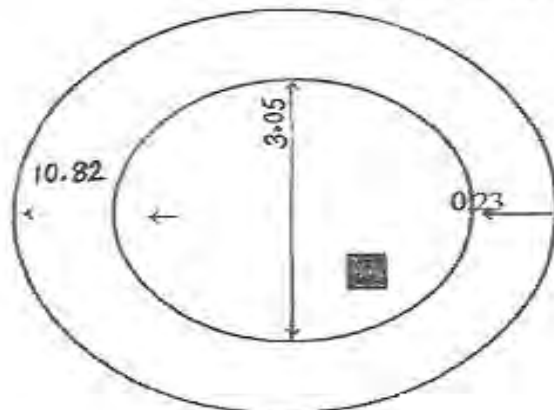

PLAN

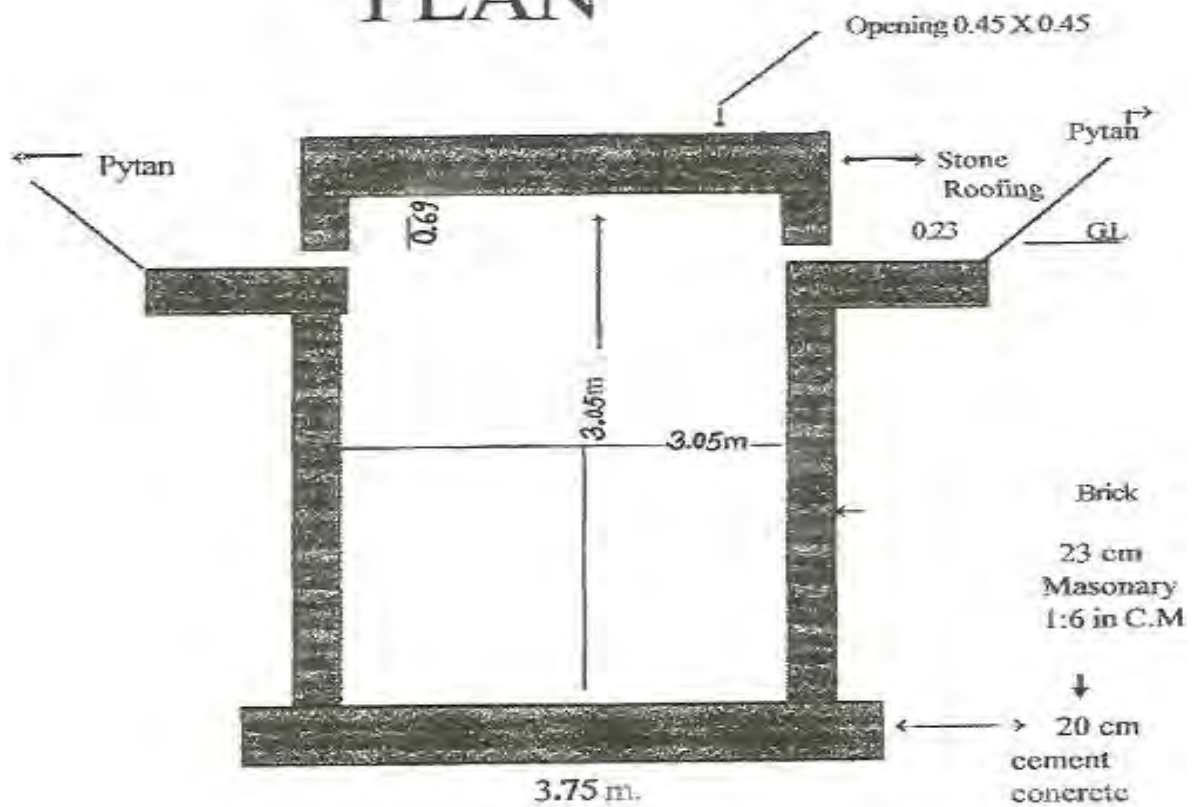

SECTION (Not to Scale)

Hence rainfall on catchment area can fillup the tanka by water

Production

Total capacity of tanka 20000 Ltr

Use of water for drinking purpose 61 % 12200 Ltr

Available water for plantation 39% 7800 Ltr

One watering requires 15 Ltr / week

No of watering per Year 52 No

Total Ltr require per plant per year $15 \times 52 = 780$ Ltr

No of plant can survive = Available plantation for Plantation/ water require per plant per year

= $7800/780=10$ plant

Hence rainfall on catchment area can fillup the tanka by water

Production

Total capacity of tanka 50000 Ltr

Use of water for drinking purpose 61 % 30500 Ltr

Available water for plantation 39% 19500 Ltr

One watering requires 15 Ltr / week

No of watering per Year 52 No

Total Ltr require per plant per year $15 \times 52 = 780$ Ltr

No of plant can survive = Available plantation for Plantation/ water require per plant per year

= $19500/780=25$ plant

I jãp
xte ipk; r
bñhikyI j
I kkyku

v/; {k
mi I fefr
¼t yxg. k½
bñhikyI j
I kkyku

Ljãp
xte
ipk; r
/kēk

v/; {k
mi I fefr
¼t yxg. k½
/kēk

Ljãp
xte
ipk; r
Aih

v/; {k
mi I fefr
¼t yxg. k½
Aih

W.D.T.
(Engg.)

ekly rdehuk tydqm@Vlak (w.H.S.) 50]000 yHj {kerk

SNo	dk; lfooj.k	No	L	W	H	Qty.	Rate	Amount
1	uhø] [kkbz i juky es 1-5 ehVj xgkjkbz rd feVh dh [knkbz djuk ry dks dlyuk] i kuh Mkyuk] cxy dks l økjuk] [knh gpz feVh dks ckgj fudkyuk] uhoa Hkj us ds ckn [kkyh djuk] LFkkus dks i q% feVh l s Hkjuk rFkk cph gpz feVh dks 50 ehVj dh njh rd fuLrkj.k djuk l [r feVh ea							
	l k/kj.k eyk; e feVh ea vkøjcMz mBkuk		15	15	0.30	67.50Cum.	76/-	5130.00
	0 l s 1-5 ehVj rd	1	$\pi/4$	$(4.50)^2$	1.50	23.84Cum.	93/-	2217.00
	1-5 ehVj l smij	1	$\pi/4$	$(4.50)^2$	3.50	55.63 Cum	103.80	5774.00
2	[knh gpz feVh dks 50 ehVj rd dh njh es Mkyuk rFkk l ery djuk i kuh Mkyuk rFkk nj eV l s dlyuk							
	vkb/e uEcj 1 ds vuñ kj					79.47	33.75/-	2682.00
3	l hehV dñdfjV uhoa; k Qe" lz es 40 feyhehVj ukllh; eki dh iRFkj bñV fxVh l hehV jr el kyk , d l hehV & 4 jr 8 feVh ds vuikr es feykj Mkyuk rFkk dlykbz djuk o rjkbz djuk							
		1	$\pi/4$	$(4.30)^2$	0.30	4.35 Cum	2222/-	9665.00
4	uhoarFkk dñ lz es i Fke Jskh dh bñ/ks dh pñkbz l hehV ctjh 1% ese; cxy dh f>jh dñ djuk							
	tdqm nhokj	1	$\pi/4$	$(4.30^2-3.60)^2$	5.00	21.70 Cum		
	ik; ru nhokj	1		$\pi*14.23*0.23*0.90$		9.24 Cum		
	?ñvkbz s buyñ	4	0.30	0.30	.35	0.126		
	dly dk; l					30.814 Cum	3050/-	93982.00
5	l lykbz , .M fQfDI x iRFkj ds fl jny 15 l ÷hehVj ekñ/kbz	2	3.50		0.30	2.10 Sqm	883/-	1434.00

SNo	dk; lfooj.k	No	L	W	H	Qty.	Rate	Amount
6	voy ntã dh iRFkj dh i fV; ka dh Nr Mkyuk Äij rFk fups l s tkMks es iRFkj dh phi ds l kFk 1% vuqkr es l heV el kyk l s hkjuk ¼ 2 l s 2.5 ehVj Liku rd ½ ft l l s 100 , e, e- ekv/kbz bV/ka dk [kM+tk ' kfev gks			$\pi/4$ $(4.30)^2$ -0.60*.60		14.51 Sqm. 0.36 14.15 Sqm	1366	19328.00
7	ik; ru ea/kkkyk ejã Mkyuk rFk njeV l s dV/kbz djuk rjkbz l er			$\pi/4 (14.0)^2 -$ $(4.30)^2 * 0.15$		20.90Cum	287.00	5998.00
8	50 eh-eh- ekv/kbz ea l h-da 1% feJ.k ft l ea 1 l heVj 2 ctjh 4 iRFkj dh fxVVh feykdj Mkyuk dWuk rjkbz l er			$\pi/4 (14.0)^2$ $- 0.60 * 0.60$		153.86 <u>.36</u> 153.50 Sqm	253.00	38835.00
8	l heV lykLVj nhokj ij 1% ea l heV ctjh feykdj tkMka dks djn nus rFk rjkbz l fgr 20 , e, e ekv/kbz e	1	$\pi/4$ π π	$(3.60)^2$ $3.60 * 5.00$ $4.30 * 0.60$		10.17 56.52 8.10 74.79Squm	127/-	9498.00
ch	20 , e, e Okezi ksM Nr ¼¼¼¼							
	ik; ru	1	$\pi/4$	$(14.00)^2$		153.86 Sqm		
	?kVkb; s	1	π	14.23 X 1.28		57.19 Sqm		
		1	0.60	0.60		.36		
	dy dk; l					210.69 Sqm	113/-	23807.00
9-	l lykbz , .M fODfl x ykgs dk njoktk , oa tkyh ¼\$ 4½		LS					1000
10	75 , e, e- i h-oh-l h- i kbã		6m.				120/-	720.00
11	Oks/ks , oa ckMz							500-00

220570.00

2 ifr'kr dUVhtã h@VBMj fMOjã

4401-00

224971-00

Say Rs. 2.25 Lac.

njaftyk ifj'kn %keh.k fodkl izdks B½ chdkuj dh ch, l -vkj- 01-04-13 , oaou folkkx dh ch, l -vkj ds vuq kj gã

Ijãp
xte ipk; r
bhikylj
l kikyku

v/; {k
mi l fevr
¼tyxg.k½
bhikylj
l kikyku

Ljãp
xte
ipk; r
/kelk

v/; {k
mi l fevr
¼tyxg.k½
/kelk

Ljãp
xte
ipk; r
Aiuh

v/; {k
mi l fevr
¼tyxg.k½
Aiuh

W.D.T.
(Engg.)

JALKUND/Tanka
CAPACITY 50,000 LTR.

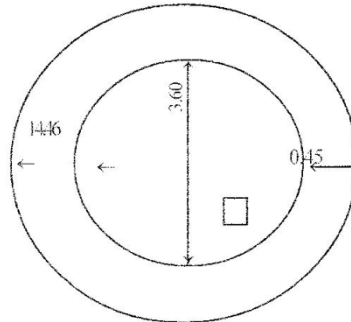

PLAN

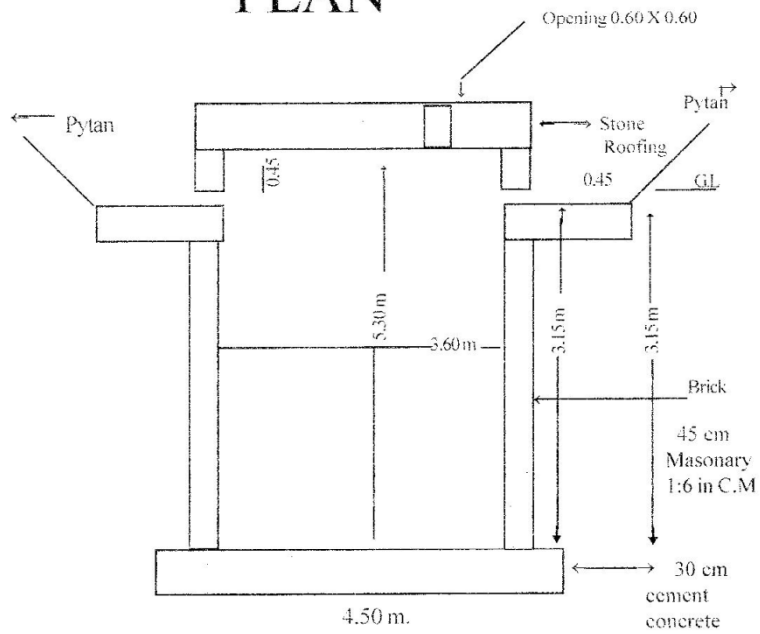

SECTION (Not to Scale)

Estimate Construction of Talai (Nadi)

1. Earth work in excavation upto 1.5 m, ramming bottom, dressing sides and Disposal of excavated material with ion lead of 50 m. in hard soil

$$\begin{aligned} \frac{55 + 43}{2} \times \frac{45+33}{2} \times 3.00 &= 5733.00 \text{ Cum} \\ 2 (54.65 + 44.65(0.35 \times 0.30)) &= 20.85 \text{ Cum} \\ 2 (42.65 + 32.65(0.35 \times 0.30)) &= 15.81 \text{ Cum} \end{aligned}$$

5769.69 Cum

$$\begin{aligned} \text{Deductiln - } 3500 \times 21.00 \times 0.90 \times 0.80 / 2 &= 446.00 \\ \text{Net work } 5323.66 @ 93/- &= \text{Rs. } 495100.00 \end{aligned}$$

2. Cement Concret in foundation with stone bllast Size 40 mm. nominal including curing & compction etc. in 1: 4: 8

$$\begin{aligned} 2 (54.65 + 44.65(0.35 \times 0.15)) &= 10.42 \\ 2 (42.65 + 32.65(0.45 \times 0.15)) &= 7.90 \\ &= 18.32 \end{aligned}$$

@ 2222/-

Rs. 40707.00

3. Brick work in foundation and plinth using brecks class designation- 75 in cm. 1.6

$$\begin{aligned} 2 \times 55.00 + 43.00 / 2 \times 6.70 \times 0.075 &= 49.24 \\ 2 \times 45.00 + 33.00 / 2 \times 6.70 \times 0.075 &= 39.19 \\ 2 (54.77 + 44.77(0.23 \times 1.20)) &= 54.95 \\ 2 (42.65 + 32.65(0.35 \times 0.30)) &= 15.81 \end{aligned}$$

159.19 Cum

@ 3050/-

Rs. 485529.00

4. 12 mm thick plaster on brick plaster on brick work including quring and racking on joints in cm 1: 4

$$\begin{aligned} 2 \times 55.00 + 43.00 / 2 \times 7.15 &= 700.70 \text{ Sqm.} \\ 2 \times 45.00 + 33.00 / 2 \times 7.15 &= 557.70 \text{ Sqm} \\ 2(55.00 + 45.00) 0.90 &= 180.00 \text{ Sqm} \\ 2(55.50+ 44.50) 0.90 &= 178.00 \text{ Sqm} \\ 2(55.00+ 44.50) 0.23 &= 44.77 \text{ Sqm} \end{aligned}$$

1662.37 Sqm

@ 102/- Sqm

Rs. 169561

Total Rs. 1190897.00

2 ifr'kr dUVht@ h@V@Mj fMQj@

23818.00

1214715.00

Say Rs.

12.15 Lacks Only

I jãp
xte ipk; r
bhikyIj
I kkyku

v/; {k
mi I fefr
½yxg.k½
bhikyIj
I kkyku

Lkjãp
xte
ipk; r
/lekk

v/; {k
mi I fefr
½yxg.k½
/lekk

Lkjãp
xte
ipk; r
Aih

v/; {k
mi I fefr
½yxg.k½
Aih

W.D.T.
(Engg.)

PLAN OF TALAI/NAI

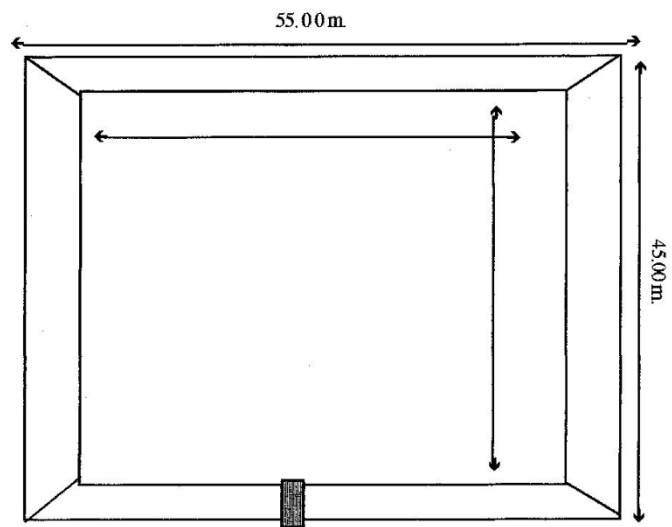

PLAN

dlclud [ksh uMsi dEikV fiV½

Ø-I a	fooj.k	ek=k	bdlbz	nj	jk'k
1-	xkø ea 1-50 ehVj xgjkblrd l [r feVVh dh [lqkb] ry dks dlnuk] cxy cxy dks l gh djuk] uhø dh [kkyh dks oki l feVVh l sHkjuk , oa cph gplz feVVh dks 50 ehVj dh njih rd gVkus dk dk; l	1.780	çfr ?ku ehVj	75/-	133.5
2-	fi V ds i fns , oa uhø ea 1% ¼ hehV] ctjh] fxVVh½ dk dcljHV Mkyuk] ftI ea 40 feeh vdkj ds i RFkj dh fxVVh gks rFkk rjkbz , oa dV/kbz dk; l	1.780	çfr ?ku ehVj	1970/-	3506.6
3-	vf/kjpuk ea bV/ dh pukkbl dk dk; l 75 oxZ uki l s 1% ¼ hehV% : tjh½ ea	2.09	çfr ?ku ehVj	2164/-	4522.76
4-	l hehV dcljHV 1% ¼ hehV% : tjh½ feVVh½ dh nhokjka dh dks i x] fdukjka dks xkyjuk bR; kfn dk dk; l 50 feeh ekv/kbz ep 20 feeh fxVVh dk uki l fgr	2.60	çfr ?ku ehVj	187.65	487.89
5-	l kexh dk i fjogu ¼ uoekfur½ ; ksx				1350/-
					10000.75

çfr uMsi dEikV fiV #i ; s10,000.00

l jãp
xte ipk; r
blhiky l j
l klyku

v/; {k
mi l febr
¼ yxg. k½
blhiky l j
l klyku

Ljãp
xte
ipk; r
/lelk

v/; {k
mi l febr
¼ yxg. k½
/lelk

Ljãp
xte
ipk; r
Aiuh

v/; {k
mi l febr
¼ yxg. k½
Aiuh

W.D.T.
(Engg.)

uMi dEik&V fiV lyku ,oa
vuqtr dW (A'A')

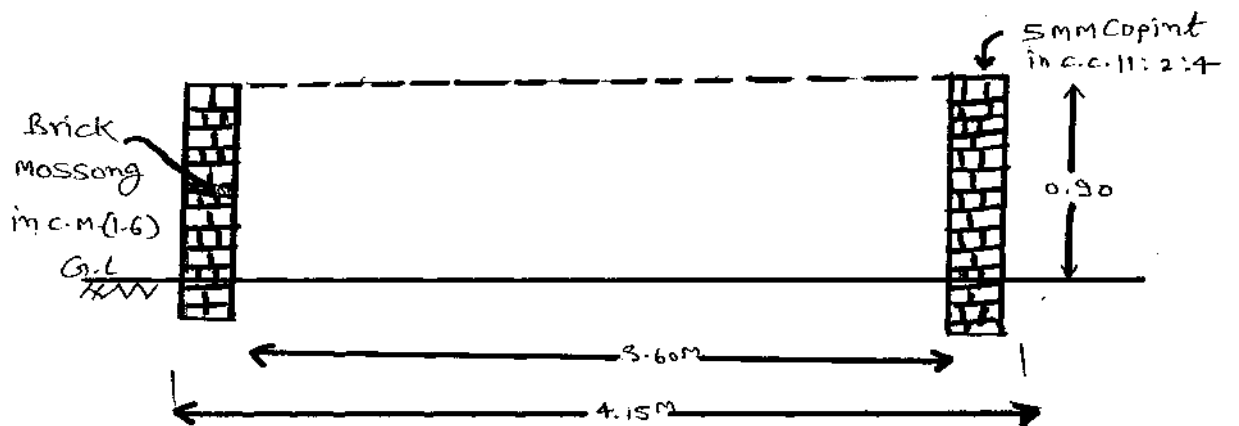
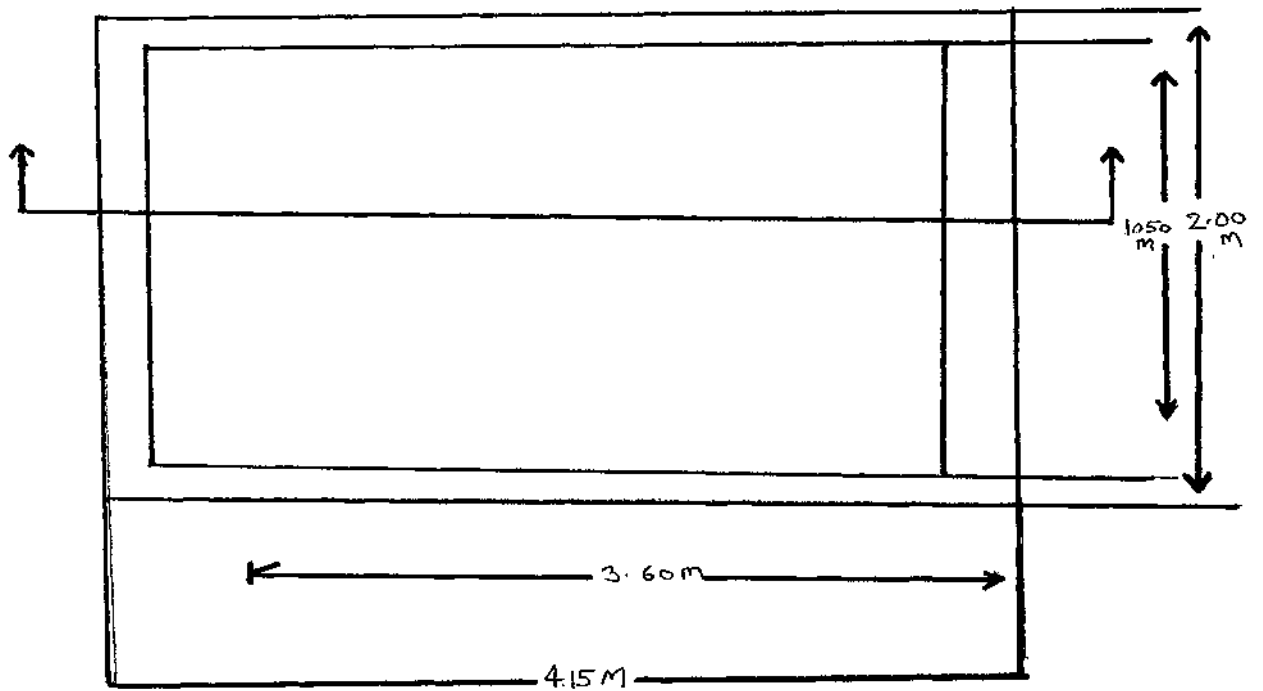

fVcck fLFkjhdj.k rdehuk ifr gDVşj

Ø-l a	dk; l dk fooj.k	ek=k	bdkbZ	nj	jkf" k
1-	ys vkAV dk; l	1@2	ifr ekuo fnol	135@&	67-50
2-	ykdy cq' k eVfj; y	13	ifr ekuo fnol	135@&	1755-00
3-	<ykbZ dk; l ykdy cq' k eVfj; y vkI ru njih 50 eVj	9	ifr ekuo fnol	135@&	1215-00
4-	eYp dh ykbuscukuk 10&10 eh- ds vlrjky es [kqkbZ djuk , oa feVh ea tekuk	18-5	ifr ekuo fnol	135@&	2497-50
5-	?kkl] chT cq'kbZ dk; l	1 gD	ifr gD	276-75	276-75
				;kx Say	5811-75 5800@&

I jAp
xte ipk; r
blhikyI j
I kkyku

v/; {k
mi l febr
½ yxg. k½
blhikyI j
I kkyku

LjAp
xte
ipk; r
/leZk

v/; {k
mi l febr
½ yxg. k½
/leZk

LjAp
xte
ipk; r
Aih

v/; {k
mi l febr
½ yxg. k½
Aih

W.D.T.
(Engg.)

pkjxlg fodkl
dk; 2¼ fr gDVj½

Ø-l a	fooj.k	ufcj	nj	dj jk'k
(A)	iklsyxklusdk dk; 2			
1	dBkj feVWh es 45 X 45 X 45 l eh uki ds xMMs djuk (0.09 cum)	200	6-80 ifr	1360.00
2.	i kskka dh dher dj 200 ux 5-00 : lk; sifr i kskk	200	5-00 ifr	1000.00
3.	i kskkjsi .k djuk dj 200 ux 3-60 : lk; sifr i kskk	200	3-60 ifr	720.00
4	i kskka dks mi yC/k i kuh fi yukuk 15 yhVj ifr i kskk	200 X 12	1-80 ifr	4320.00
5	i kskka dh fuMkbz xMkbz djuk 15 l eh xgjkbz rd rFkk 45 l eh v) 20; kl rd	200 X 6	1-20 ifr	1440.00
6	Fkkoyk cukuk de l s de 50 l eh v) 20; kl dk	200	1-80 ifr	360.00
7	i kskk [kMMs rd ykdj [kMMs es dhVuk'kd l s mi pkj dj i kskkjsi .k djuk	200	5-35 ifr	1070.00
8	i kskk ifjogu tyxg.k {ks rd	200	3-00 ifr	600.00
9	3 o'kz dsfy, i kskka dh fuxjukh , oaj [kokyh ½0 fnu ifro'kz	200 lyku	1-50 ifr	300.00
			20 ifr'kr	11170.00 2234.00 13404.00
	xi fQfyx			
B	ckM+clnh dk; 2			
1	dkk/nkj rkj [kjh e; ifjogu ¼12&14½ xst ft l ea 10 l eh njih gks 120 oxzhVj ifr gDVj ¼ 120 x 4 x 1-43@104	0.69	49000 ifr Vu	3318.00
2	vkl hl h fQfuil x i ky	22	168-49	3706.78
3	, xy vkbju i ky dks l hehV dajhV 1%4% dks feJ.k l f ½0 + 20%@2 x 30 ?ku l eh es Cykkl cukuk e; rjkbz kr fnol , oafQDI	22	30-60	673.00

Ø-I a	fooj.k	uEej	nj	dy jk'k
	djuk Up to 5 Km			
4	dka/nkj rkj dks [kky dj [khpuk , oa iky dh fu/kkzjr Nnka ij etcirh l sthvkbz ok; j ckakuk , oauV ckV l s dl uk	480 M.	78 i\$ sifr	374.40
5	ckjcM+ok; j dks ykadyh ctk l seVsj; y doj djuk	480 M.	3-59 ifr	1723.20
6.	dka/nkj rkj dks ,ky ij ckakus gsrqckbfMax gsrq ckbfMax ok; j dh [kjhn (20 X 0.007) xst	1.55 kg.	60 ifr fdyks ½ctkj nj½	93.00
	A + B			23355.00
			Say	23360.00
	Total area of PD work in Lakhasar 13ha Add for construction of forest nut and contingences		Say	303700.00 36300.00 <hr/> 340000.00

Note : mDr njaftyk ifj'kn ½kxh.k fodkl izdks B½ chdkuj dh ½ch, l vkj 01-04-13½ dh , oaeq; ou l j {k.k vkbzth, ui h] chdkuj dh ch, l vkj l syh xbZ gA

I jãp
xle ipk; r
blhikyIj
l kkyku

v/; {k
mi l febr
½yxyg.k½
blhikyIj
l kkyku

Lkjãp
xle
ipk; r
/kelk

v/; {k
mi l febr
½yxyg.k½
/kelk

Lkjãp
xle
ipk; r
Aih

v/; {k
mi l febr
½yxyg.k½
Aih

W.D.T.
(Engg.)

tyxg.k {s- y[kl j IWMP-27
emly rdehuk ½kl cøkbzdk; ½ifr gØVsj

<u>Ø-l a</u>	<u>dk; l dk foøj .k</u>	<u>ek=k</u>	<u>bdkbz</u>	<u>nj</u>	<u>jkf'k</u>
1-	/kke.k cht dher	6 Kg	ifr Kg	38@&	228-00
2-	/kke.k cht ifjogu	6 Kg	ifr Kg	0-60@&	3-60
3-	?kkl cht dh xlfy; ka cht] [kkn] ckyw, oafpduhj nēV feVvh ea 1%2%2%2 ds vuqkr eafeykdj cukuklQkj tV ch, l vkj ½	6 Kg	ifr Kg	24-06@&	144-24
4-	/kke.k dscht dh xlfy; ka fMcfyæ }kj k cksk	1 gØ	ifr gØ	226-75	226-75
				; kx	602-59
				Say	600-00

I jãp
xte ipk; r
blhikyI j
I klyku

v/; {k
mi l febr
½tyxg.k½
blhikyI j
I klyku

Ljãp
xte
ipk; r
/kelk

v/; {k
mi l febr
½tyxg.k½
/kelk

Ljãp
xte
ipk; r
Aiuh

v/; {k
mi l febr
½tyxg.k½
Aiuh

W.D.T.
(Engg.)

MODEL ESTIMATE

Agro forestry Plantation

S. N.	ITEM	NO.	QTY	RATE IN RS.	AMOUNT IN RS.
1.	Digging of pits in ordinary soil of size 0.45 x 0.45 x 0.45m	100	100	7.50	750.00
2.	Planting of Plant including local transportation of plant up to pit	100	100	4.50	450.00
3.	Weeding & Hoeing up to 15 cum depth in thawala of 0.45 cum radius	100 X 3	300	2.50	750.00
5.	Cost of Plant (As per Forest Department)	100	100	7.00	700.00
7.	Preparation of Basin	100	100	2.50	250.00
	TOTAL				2900.00

çfr i kškk Hkçrku #i ,

29.00

35% Rate increase as forest B.S.R.

10.15

39.15 Say Rs. 40.00 Per plant

I jãp
xte ipk; r
blhikyI j
I kçkyku

v/; {k
mi I fefr
½ yxg. k½
blhikyI j
I kçkyku

Lkjãp
xte
ipk; r
/lelçk

v/; {k
mi I fefr
½ yxg. k½
/lelçk

Lkjãp
xte
ipk; r
Aiuh

v/; {k
mi I fefr
½ yxg. k½
Aiuh

W.D.T.
(Ag.)

Model Estimate
ARID HORTICULTURE

S.N.	Item	Qty	RATE	AMOUNT
1.	Digging of pits in ordinary soil (0.6 x 0.6 x 0.6 mtr.)	10.216 Cum	56	12.09
2.	Planting of plants including filling of earth & remming of soil	1	10	10.00
3.	Hoeing work for breaking of capillary action after watering	3	2.5	7.5
4.	Treatment of pit with insecticide including cost of insecticide	1	10	10.00
5.	Cost of plant (av.cost of horticulture plants) including transportation	1	20	20.00
6.	Transportation of Plant with Avg. lead 40 km,	1	4	4.00
7.	Preparation of Basin	1	2.5	2.5
	TOTAL			66.09

SAY RS. 66.00

35% Rate increase as forest B.S.R. 23.14

89.14

Say Rs. 90.00 per plant

I jãp
xte ipk; r
blhikyI j
I kãkyku

v/; {k
mi I fefr
½ yxg. k½
blhikyI j
I kãkyku

Ljãp
xte
ipk; r
/kelk

v/; {k
mi I fefr
½ yxg. k½
/kelk

Ljãp
xte
ipk; r
Aïuh

v/; {k
mi I fefr
½ yxg. k½
Aïuh

W.D.T.
(Ag.)

cktjk ifr bdkbzykxr 10-4½

vkuku	ek=k	nj ½vuøkfur½	vuøkfur jkf'k
cht	1.50kg ½	32.00@kg	48.00
mojd			
Mh, -ih	26.0kg ½	552 per Bag	271.44
; fj; k	16.00kg ½	279 per Bag.	89.28
dYpj iðV	4 pkt	8.25 per pkt	33.00
i ksl - j l k; u			250
; kx			691.72

Say -700

Xokj ifr in'ku bdkbzykxr 10-4 g½

vkuku	ek=k	nj ½vuøkfur½	vuøkfur jkf'k
cht	2kg ½	200.00@kg	400.00
mojd			
Mh, -ih	20kg ½	552 per Bag	220.8
dYpj iðV	4pkt	10 per pkt	40.00
i ksl - j l k; u			330.00
; kx			990.80

Say - 1000

eB ifr in'ku bdkbzykxr 10-4 g½

vkuku	ek=k	nj ½vuøkfur½	vuøkfur jkf'k
cht	8 ½kg ½	35.00@kg	280.00
mojd			
Mh, -ih	30 ½kg ½	552 per Bag	315.28
dYpj iðV	2+2 =4pkt	10+6.50	33.00
i ksl - j l k; u			265.00
; kx			893.28

Say - 900

ek ifr in'ku bdlbzykr 10-4 g%

vkuku	ek=k	nj ½vuþfur½	vuþfur jkf'k
cht	8 ½kg ½	40.00@kg	320.00
mojd	-	-	-
Mh, -ih	30 ½kg ½	552 per Bag	315.28
dYpj iðV	2+2 =4pkt	10+6.50	33.00
isl - jlk; u			265.00
; lxx			933.28

Say - 1000Rs.

Ljap
xte ipk; r
blhikyIj
lkkyku

v/; {k
mi l febr
½yxg.½
blhikyIj
lkkyku

Ljap
xte
ipk; r
/kelkk

v/; {k
mi l febr
½yxg.½
/kelkk

Ljap
xte
ipk; r
Aih

v/; {k
mi l febr
½yxg.½
Aih

W.D.T.
(Ag.)

Model technique of shelter belt (3 row)

Mid row made by big trees 8-10 m long like neem, karanj, desi kikar etc.

No of plantation big tree in one ha area = $100(\text{length of field}) / 10$ (plant to plant distance) = 10 plant

Plantation of shrub or small tree 5-6 m long like desi ber, ker, kumat etc. in both side of mid row of big trees

No of plantation shrub or small tree in one ha area = $100(\text{length of field}) / 5$ (plant to plant distance) = 20 plant in one side

No of plantation shrub or small tree in two side of big tree = $20 \times 2 = 40$ plant

Total no of plant for shelter belt in one ha field = 50 plant

Cost of one plant = 40 Rs

50 plant cost = $40 \times 50 = 2000$ Rs



Creation of small-scale turbulence in the wake of a shelter and recovery of the undisturbed flow downwind

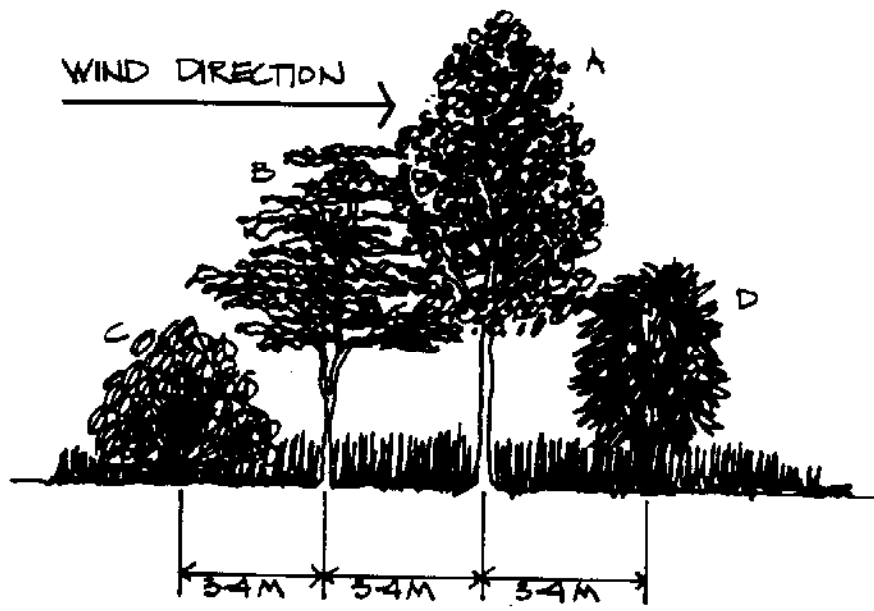

This windbreak is protecting the cropland from high winds, which would carry away topsoil and make the land useless for farming.

I jāp
xte ipk; r
blhikyI j
I kkyku

v/; {k
mi I fefr
½yxg. ½
blhikyI j
I kkyku

Ljāp
xte
ipk; r
/elk

v/; {k
mi I fefr
½yxg. ½
/elk

Ljāp
xte
ipk; r
Aih

v/; {k
mi I fefr
½yxg. ½
Aih

W.D.T.
(Ag.)

ESTIMATE

Fodder demonstration

BARSHEEM (0.4 HA)				
S.N.	ITEM	QTY	RATE IN RS.	AMOUNT IN RS.
1.	Soil treatment by carbofuran	60 kg	5.00	300.00
2.	SSP	22 kg	6.60	145.20
3.	Seed cost	12 kg	13.00	156.00
	TOTAL			601.2

Say -600

BAJARA (0.4 HA)				
S.N.	ITEM	QTY	RATE IN RS.	AMOUNT IN RS.
1.	Soil treatment by carbofuran	60 kg	5.00	300.00
2.	DAP	25 kg	11.04	276.00
3.	Seed cost	4 kg	7.00	28.00
	TOTAL			604.00

Say -600

OAT (0.2 HA)				
S.N.	ITEM	QTY	RATE IN RS.	AMOUNT IN RS.
1.	Soil treatment by carbofuran	30 kg	5.00	150.00
2.	DAP	12 kg	11.04	132.48
3.	Seed cost	20 kg	16.00	320.00
	TOTAL			602.00

Say – 600

I jþp
xte ipk; r
blhikyI j
I kkyku

v/; {k
mi I fefr
¼yxg.½
blhikyI j
I kkyku

Ljþp
xte
ipk; r
/kelk

v/; {k
mi I fefr
¼yxg.½
/kelk

Ljþp
xte
ipk; r
Áiuh

v/; {k
mi I fefr
¼yxg.½
Áiuh

W.D.T.
(Ag.)

Model Estimate of Horticulture Orchard (1 Ha)

Total area = 1Ha or 100x100 M²

Plant to plant x row to row distance of horticulture plant like (buded ber , aner ,nimbu , lasova , karonda)= 6x6

Total No. of plantation of 1 Ha area = 100x100 / 6x6 = 278

OAT (0.2 HA)			
ITEM	QTY	RATE IN RS.	AMOUNT IN RS.
Cost of plantation	277	90.00	24930
Shelter belt cost of one ha area	1	2000.00	2000.00
SSP	278 kg	6.60	1834.00
Plant for gape filling 25 % of total plant	69	20.00	1380.00
TOTAL			30144.00

Say -30000

ulw %mDr njh fn'k funzk Q'z 2011&12] dk; ky; mi funskd df'k %oLrkj½ ftyk ifj'ln]- chdkuj o df'k foLrkj funskky; %SKRAU, Bikaner½yh xbzgã

I jãp
xte ipk; r
bhikyIj
I kkyku

v/; {k
mi I fefr
½yxg.k½
bhikyIj
I kkyku

Ljãp
xte
ipk; r
/lelk

v/; {k
mi I fefr
½yxg.k½
/lelk

Ljãp
xte
ipk; r
Aih

v/; {k
mi I fefr
½yxg.k½
Aih

W.D.T.
(Ag.)

ty xg.k fodkl dh ipo'kz i'kikyuu ;kstuk

vkt ;æ izkku ;æ gkrs gq Hkh ge d'k dks NkM+ ugha l drA gekjh l dfr , oa l H; rk ea d'k gsrq i'kikyuu dks utj vntk ugha fd; k tk l drkA xteh.k {ks= ea l kekftd , oa vkfFkd fodkl gsrq i'kikyuu fodkl dh vr; Ur vko'; drk gSD; kfd 80 ifr'kr l s vf/kd xteh.k ifjokj i'kikyuu ikyrs g\$ y?kq rFkk l hekUr d'kdka dh yxHkx 35 ifr'kr vk; Ms jh o i'kikyuu l s gh g\$ rFkk jkT; ds l dy ?kjsy mRikn ea i'kikyuu dk ; ksnku yxHkx 9-16 ifr'kr gA vr% ty l xg.k ifj; kstuk dk , d eq; ?kVd i'kikyuu fodkl l s l Ec) g\$ft l ea i'kikyuu fodkl gsrq fuEufyf[kr mnns; ka dks l fEefyr fd; k x; k g\$&

- i'kikyudka gsrq tkx: drk f'kfojka dk vk; ktuA
- i'kikyuu ds fofHkUu jkska dh jkdFkke o mi pkjA
- i'kikyuu ea ek\$ eh chekfj; ka l s cpko gsrq Vhdkdj .kA
- i'kikyuu ea df=e xHkz'kku dh l fo/kk eg\$ k djokukA
- mUke ns kh uLy ds i'kikyuu dk l j {k .kA
- vdkfNr uj i'kikyuu dk cf/k; kdj .kA
- i'kikyudka dks i'kikyuu ds uLy] izU/kU] i'kikyuu k] LokLF;] ijthoh jkska dh tkudkjh inku djukA
- i'kikyuu k gsrq pkjxkg izU/kU] pkjs nkus dh tkudkjh] tgjhys pkjs inkFkka dh tkudkjh] [kfut yo .kka dh egUkk l e>kukA

vr% mDr mnns; ka dh i'kikyuu gsrq tyxg.k fodkl ifj; kstuk ds vrxr Jh Mxjx<+ i'kikyuu; r l febr ds tyxg.k fodkl ifj; kstuk {ks= dk o"z 2010&11 l s 2014&15 rd dsfy, p; u fd; k x; k g\$

tyxg.k fodkl ifj;ktuk eai 'klu l ædh ef; l eL;k,a&

- tkx: drk dk vHkkoA
- i 'kq i kSk.k l ædkhA
- i 'kq jkska l ædh tkudkj h dk vHkkoA
- pkjk mRi knu] Hk&/kj .k l ædkhA
- gkbžthu l ædkhA
- iztuu jksks l ædkhA
- vokfNr i 'kq ka ds l efpr mi ; ksx l ædkhA
- ukckMZ ; ktuk dh tkudkj h dk vHkkoA

bu mi jkDr l eL; kvka ds fuokj .k grqfofHkku dk; Zfu"i kfnr fd; s tk; xA

i 'kylaeaVhdkdj.k f'foj % Hk&/ka ea bZ/h-oh- o i kDI rFk xk; Hk& ka ea , Q-, e-
Mhj , p-, l - rFk ch-D; w dk Vhdkdj.k i 'kq i ky u foHkx ds l g; ksx l s fu/kkZjr njka
ij fd; k tkoxkA

i 'kylaeacla i u fuokj.k f'foj dk vk;ktu %

o'ž esnkskj

fofHkku vkskf/k; ka dh vuøkfur dher 51500@& :

20 fnu ckn Qksy&vi ea vkskf/k; ka dh vuøkfur dher 30000@& :

vuøkfur okgu fdjk; k 1950 x 2 = 3900@& :

ipkj l kexh o vU; 0; ; 2000 x 2 = 4000@& :

njh V8V 0; ; @fdjk; k 1000 x 2 = 2000@& :

pk; fclDw/ uk'rk 500 x 2 = 1000@& :

7000@& :

7000 x 2 = 14000@& :

, d f'foj dk vuøkfur dy 0; ; 85400 + 14000 = 99400@& :

**ukv%bl f'foj ea 100 i 'kylae dk mipkj fd;k tk; xk rFk f'foj dk l Eiknu
i 'kkyu foHkx chdkuj vFlak i 'kqpfdrI k ,oa i 'kqfoKlu egkfo |ky; chdkuj
dsl g; ksx l sfd; k tkoxkA**

i 'kylaeami pkj grqpfdrI k f'kfojlaek vk; kst u &

i R; d xkø ea o"lz ea nks ckj pfdRI k f'kfojka dk vk; kst u fd; k tk; skA

1- f'kfoj grqdepkfj; ka dh I d; k %5

1/4CY; wMh- Vh- ds vfrfjDr½

2- f'kfoj dh vof/k %2 fnu

3- f'kfoj ij vuøkfur 0; ; %

4- f'kfoj ij vuøkfur 0; ; %

1- nokb; ka dk Ø; eW; % 20000@& : -

2- i pkj i d kj I kexh o vU; 0; ; % 600@& : -

3- okgu fdjk; k % 2400 @& : -

4- fofok % 1000 @& : -

vuøkfur dy 0; ; % 24000@& : -

uk% f'kfoj dk I Eiknu i 'kikyuu foHkx chluj vFløk i 'kq pfdRI k ,oa i 'kq foKku egfo/ky; chluj ds I g; kx I sfd; k tloxA

i 'kylaeacf/k; kdj .k f'kfojlaek vk; kst u %

i R; d xkø ea o"lz ea nks ckj cM&o Nks/s uj i 'kq/ka ds fy; s cf/k; kdj .k f'kfoj dk vk; kst u Ik'kikyuu foHkx ds I g; kx I sfd; k tloxA bl dk; Z dks i kj n'khZ ,oa vI jnkj cukus grq cf/k; kdj .k djus okys Ik'køku I gk; d dks cM& Ik'kq dk cf/k; kdj .k djus ij 10 @& ifr i 'kq rFk Nks/s i 'kq dk cf/k; kdj .k djus ij 5@& ifr i 'kq dh nj I s i kRI kgu jkf'k nus ij vuøkfur okf"kd 0; ; 25500@& dk gkxA

vPNh uLy dsuj i 'kylæk Ø; ,oaforj.k %

tyxg.k fodkl ifj; kst uk {ks= ea vPNh uLy dsuj Ik'kq/ka dh deh I sfd I kuka dks i j s kkuh gks jgh gS rFk i 'kikyuu foHkx dh vkj I s bl ckr- dkbZ dk; Z ugha fd; k tk jgk gA vr% fuEuku d kj uj Ik'kq/ka dks Ø; djds forj.k fd; k tkos rks i 'kq i kydka dks ykHk feysxA I kFk gh vPNh uLy ds cPps i ñk gkxA

bl dk; Z grq vPNh uLy ds I kM 1/4 kBh@gfj; k.kk½ dh vuøkfur ykx 15000&20000 : i; s ifr I kM gksch rFk Hk k 1/2 ej k½ dh vuøkfur ykx 50000&55000 : i; s ifr Hk k gkschA cdjk 1/4 teuk ikh 1/2 4500&5000 ifr cdjk ,oa esk 1/2 kjokM½ 5000&7000 ifr esk gkschA

uk% %ifjogu 0; ; ,oaØ; I fevr ij 0; ; fu; eku d kj vyx I snš gkxA

INFERTILITY CAMPS

Infertility is a major cause of low reproductive performance in dairy cows. Under field conditions many cows do not either come in to estrus or do not conceive for prolonged period. A frequent mistake by animal owners is that they do not refer their animals for pregnancy diagnosis after Artificial Insemination or Natural Service or do not bother about animals not returning to estrus for long time (sometimes upto 12 months) post partum. Farmers must be educated for proper and timely therapy of these two group of animals as this would his problems and increase his profitability. The problem of animals not returning to estrus is basically a management error. Under most conditions in which rural cows are reared poor nutrition is provided to increase infertility.

The major problems that constitute infertility in rural cows includes :-

- 1- Anoestrus
- 2- Genital infection
- 3- Ovarian cysts
- 4- Repeat Breeding
- 5- Genital adhesions
- 6- Anatomical defects

When infertility camps are organised at rural areas a major problem encountered is anestrus which is one of the biggest disorder of rural cattle & Buffalo of Sri Dungargarh Panchayat Samiti area.

Estimated Budget for Infertility in Cows & Buffalo

100 Animals

- 55-60 Cow/Heifer would be anoestrus
- 15 Cows would be having genital infection
- 15 Cows would be repeat breeders
- 5 Cows would be having adhesions & 1 Cow may have anatomical defects

Best Therapies for

Anestrus : 60 Cows

1. Mineral Mixture 1 Kg for each i.e. 60 Kg, Cost/Kg. Rs. 100

$$100 \times 60 = \text{Rs. } 6000/-$$

2. Inj. Vit A Rs 50/- & Phosphorus etc Rs. 100/-

$$150 \times 30 = \text{Rs. } 4500/-$$

3. Hormonal CIDR-B + E2 + FSH

$$\text{Rs. } 650/- \text{ Rs. } 50/- \text{ Rs. } 300/-$$

$$1000 \times 30 = \text{Rs. } 30000/-$$

Genital Infections 15 Cows

Antibiotics I/U + Parenteral

$$\text{Rs. } 100/-$$

$$100 \times 15 = \text{Rs. } 1500/-$$

Ovarian Cysts 5 Cows

Inj. Pubergen 5000 I.U. Rs 350 X 5 = Rs. 1750/-

Inj. Receptal / Inj. Gyna Rich 5 ml. Rs. 250 X 5 = Rs. 750/-

+ Inj. Duraprogen + Inj. Intavita H/E Carese

$$\text{Rs. } 50/- \quad \text{Rs. } 80/- \quad \text{Rs. } 70/-$$

$$200 \times 5 = \text{Rs. } 1000/-$$

Repeat Breeders 15 Cows

Inj. Vit + Progesteron 400 X 15 = Rs. 6000/-

$$\text{Rs. } 50/- \quad \text{Rs. } 350/-$$

Adhesions/Anatomical Defects 5 Cows cannot be treated considered for hormonal induction of lactation.

Estimated Expenditure on Medicines Rs. 51500/-

Follow up programme after 20 days will cost of Medicines Rs. 30000/-

Vehicle to be hired @ Rs. 7/- per Km Rs. 1950 x 2 = Rs. 3900/-

Total Estimated Expenditure on one Camp Rs. 85400/-

Financial Benefits and Advantages to the Breeders

It is observed that the success rate is 40% by treating the cows and buffaloes with this line of treatment. All 40 cows/buffaloes will come in estrus and conceive.

After one year, after parturition the milk yield of these animals will be approximately as under :-

40 cows/buffaloes

5 lit./day/cow will be $40 \times 5 = 200$ lit.

Milk yield for 300 days will be $200 \times 300 = 60000$ lit.

Average rate/lit. Rs. 15 than income $60000 \times 15 = \text{Rs. } 900000/-$

Expenditure on feed and fodder

Fodder is already provided to these animals by farmers when these were not giving milk. In spite of this we consider Rs. 15/ day/animal on this expenditure.

Cost of fodder $15 \times 40 \times 365 = \text{Rs. } 219000$

Cost of feed 2 kg/day/animal $40 \times 2 = 80$ kg

Cost of feed Rs. 10/- per kg for 300 days will be $80 \times 10 \times 365 = \text{Rs. } 292000/-$

Cost of feed & fodder $\text{Rs. } 219000 + 292000 = 511000$

Net income per year $\text{Rs. } 900000 - \text{Rs. } 511000 = \text{Rs. } 389000/-$

In second lactation suppose minimum increase in milk yield is 1 lit./day/animal.

Than yearly additional financial benefits to farmer will be

$1 \times 40 \times 300 \times 15 = \text{Rs. } 180000/-$

If the price rate of milk and feed increases in same proportion.

Breeder can sale his animals after pregnancy or after parturition to get more money.

These camps will be organized with the co-ordination & help of college of veterinary & Animal Science, Bikaner.

Ljap
xte ipk; r
blhikyI j
I kkyku

v/; {k
mi I fefr
¼yxg.½
blhikyI j
I kkyku

Lljap
xte
ipk; r
/lekk

v/; {k
mi I fefr
¼yxg.½
/lekk

Lljap
xte
ipk; r
Aih

v/; {k
mi I fefr
¼yxg.½
Aih

W.D.T.
(Ag.)

Convergence with Agriculture Ext. Department

Project comprises each and every scheme of ext. department whatever it will be possible to benefited farmers.

(Rs. in lacs)

(A) Hand operated chaff cutter

No.	Unit Cost	Total Cost
96	0.02	1.92

Power operated chaff cutter

No.	Unit Cost	Total Cost
25	0.10	2.50

(B) Crop Demonstration

No.	Unit Cost	Total Cost
2200	0.0045	9.90

(C) Horticulture

No.	Unit Cost	Total Cost
40	0.30	12.0

Convergence with NREGA

Project comprises Tanka for SC/ST with convergence to NREGA.

No.	Unit Cost	Total Cost
25	0.60	15.00

Total Convergence Cost :

Convergence with Agriculture ext. Department 29.60

Convergence with NREGA 15.00

i 'l'kyu miHØrk I eg

Ø-I a	d'ld dk ule	firk@ifr dk ule
1-	Hkxhj Fk	mnkjke
2-	Qd kjke	dkyjke
3-	Hkxi kjke	tho.kjke
4-	dskj	jckjke
5-	ukFkh	gpekjke
6-	běj rh	eykjke
7-	epdk	rstkjke
8-	ckcyky	ekujke
9-	fyNek	l xukjke
10-	etuh	ekyjke
11-	ekgunkl	i wknkl
12-	ekyjke	rkykjke
13-	Hskjke	l jrkjke
14-	fdl uk	ekyjke
15-	fdl ukjke	Hkhckjke
16-	rkykjke	Hskjke
17-	l hirkdøj	xyc fl g
18-	Hkøj h	Hkxi kjke
19-	fyNek	l jrkjke
20-	Nxuh	rstkjke

t f o d d f ' k m i H k Ø r k l e g

Ø-l a	d'ld dk ule	firk@ifr dk ule
1-	xgyc fl g	[kno fl g
2-	gpekjke	dkyjke
3-	e?kh noh	ekrhjke
4-	l Eir	cdkkjke
5-	dljuh	dj .kkjke
6-	eluhjke	ekrhjke
7-	yknjke	: i kjke
8-	ikj noh	Hkøjkjke
9-	Hkøjh	jke/ku
10-	xhrk	dqkykjke
11-	xkerh	dskjke
12-	bějrh	ewkjke
13-	/kki noh	gjhjke
14-	fy{ek	l økjke
15-	Hkøjkjke	l jrkjke
16-	fd'kuk	l R; ukj; .k
17-	Hkøjyky	: ?kjke
18-	xk; =h noh	ckcyky
19-	l jkst	gjhjke
20-	l jrk jke	ekgkjke

d'k ofudh ,oam | k'udh mi HØrk I eg

Ø-I a	d'kd dk ule	firk@ifr dk ule
1-	enufl g	ekyfl g
2-	e?kkjke	dllg\$ kyky
3-	y{e.k	' ; keyky
4-	clqk.kkjke	dkst kjke
5-	fyNek	txnh'k
6-	'kj kjke	eky kjke
7-	Hkj r fl g	j.kthr fl g
8-	jkejke	fjxr kjke
9-	frykdkjke	uk\$ xjke
10-	: de.kh	uk\$ xjke
11-	dkst kjke	rky kjke
12-	I hrkjke	uki kjke
13-	nokjke	frykdkjke
14-	ywkkjke	rky kjke
15-	'kadjyky	j\$kkjke
16-	Hkkuhjke	: i kjke
17-	nøhyky	fd'kukjke
18-	' ; ke I tñj	xaki rjke
19-	fy{e.kkjke	x.ki rjke
20-	I UrkSk	vkl qkl

d'kd l ph xle blhiky l j l kkyku

Ø-l a	dk'rdkj dk uke	tkr	[kl jk l ;k	{ls-Qy
1-	v.krkjke i ɸ jkeukj; .k	ckā.k	190]227	4-5900
2-	v.knkjke i ɸ puukjke	l ɸkkj	289@132	8-6900
3-	vejk i ɸ puuk	dɸgkj	252	5-7600
4-	blnknoh i fRu enuyky ' ; kel ɸnj] foukndɸkj] foeyk] fi = enuyky	ckā.k	194	3-5900
5-	bɸhnoh /kel i fRu /kukjke	pekj	80	6-5600
6-	mnkjke egkohj i l kn fi- jɸlrjke	l ɸkkj	100	8-6600
7-	dj.knkl jrunkl l ɸknkl fi- dsknkl	l kk	73] 271@74	5-3600
8-	fd'kuknoh /k-i- eɸkkjke	tKV	240	6-3900
9-	fdl ukjke i ɸ jkejke	tKV	72	3-8800
10-	jkfgr [kkrnkj		143]181	12-50000
11-	dɸ.kkjke i ɸ ekykjke	tKV	53]165	13-5500
12-	dɸkykjke oYn fdLrjkjke	tKV	250	10-5600
13-	dskj i fRu Lo- ukud	tKV	199	20-8400
14-	dskjkjke i ɸ vknjke	ckojh	134	5-8200
15-	dskjkjke i ɸ /kukjke	tKV	277@41]281@278	4-3100
16-	dskjkjke i ɸ l kgujke	pekj	293@166	3-2200
17-	dskjke i ɸ yPNhjke	ckā.k	75	3-7200
18-	dkstjkjke dkukjke Vhdjke i kuk dkyh	pekj	69]163]168	18-2000
19-	dkstjkjke dkukjke Vhdjke i kuk dkyh i ɸ	pekj	174	17-1900
20-	f[kjktjke i ɸ yqkkjke	tKV	232	3-0400
21-	[kha kjke i ɸ ukj; .kjke	tKV	303@247] 307@148	6-3700
22-	[krkjke jktjke fi- ek/kjke	tKV	86]90]106]112]154	42-8700
23-	fxj/kjhyky i ɸ ekykjke	tKV	239	5-0900
24-	fxj?kkjhyky i ɸ ekykjke	tKV	96	4-7000
25-	fxj/kjhyky i ɸ ekykjke	tKV	97	5-6000

Ø-I a	dk'rdkj dk uke	tkr	[kljk l ;k	{k-Qy
26-	xhrk i fRu Lo- ftudkjke	ckā.k	99]116]156	17-6900
27-	xki kyjke oYn plnkjke	tKV	209	6-9600
28-	xkj k i fRu Lo- ewkjke	eškoky	50	4-9400
29-	prjfl g i ę ekyfl g	jktiwr	152]153	5-8200
30-	prjfl g i ę ekyfl g	jktiwr	16	6-3700
31-	pllnjru i ę ukjk; .kjk	tKV	110]312@111	4-1400
32-	pllnkjke i ę ekykjke	l ękkj	298@172]300@26 1]302@262	8-2700
33-	Nkskjke i ę dkMkjke	tKV	253@169	2-5300
34-	Nkskjke i ę dkMkjke	tKV	158	4-6100
35-	tkyjke i ę ukjk; .kjk	tKV	308@242	5-1600
36-	tkyjke i ę ukjk; .kjk	tKV	225	3-0400
37-	tš kjke mekukjke fj l kyjke i ukjke /kMh	tKV	124@125	14-32000
38-	tš kjke mekukjke fj l kyjke i ukjke /kMh	tKV	15]182]217	17-9500
39-	tš kjke oYn dškkjke	tKV	122]123]189	7-3200
40-	'kkuk oYn bžoj	tKV	29] 254@28	4-3100
41-	'kkukjke i ę bžojjke	tKV	193	7-0800
42-	>edmoš /k-i-t; ukjk; .k	vks>k	251	6-2300
43-	Mkbž i fRu Lo- ftudkjke gMekukjke		215	2-7300
44-	dšyk' kplnz jk/kk fi- ftudkjke	ckā.k	220	10-5000
45-	rhtknøš /k-i- ujl kjke	tKV	264@78	5-0900
46-	ryNkjke Hkř kjke fi-ukujke	tKV	159	4-6100
47-	rstkjke i ę pųkjke	tKV	309@242]315@11 1	9-3000
48-	rkykjke i ę jkejke	tKV	4	0-6500
49-	rkykjke oYn xki ky	ckā.k	59]60]170]171]173	17-9500
50-	nkukjke i ę l kgujke	pekj	292@113	3-2300
51-	nøhyky i ę ukjk; .k	tKV	51] 306@148]310@52	6-3800
52-	/kiki wi fRu Lo- guękjke	ckā.k	288@133	7-1000

Ø-I a	dk'rdkj dk uke	tkr	[kljk lē;k	{k-Qy
53-	/kkinoh /k-i- ryNkjke	tKV	160	1-4500
54-	ufkjke iē vknjke	tKV	85]108]246	27-0200
55-	ujl kjke >ējey dŷk'kplnz jkeplnz fi- bz ojke	ckā.k	141	5-5000
56-	uoyfd'kkj iē jkeukjk.k	ckā.k	226	4-3000
57-	ukudjke iē vknjke dkē	ckojh	84]138	5-8200
58-	fujk; .kh i fRu Lo- ukujke	tKV	146	10-2600
59-	ukjæjke eskjke ukjk; .kh xhrk jktwvk'kh		241	10-5900
60-	i ukjke oYn [kh; kjke	ckā.k	77]265@78	18-5500
61-	i hpinoh /k-i- gækjke	tKV	216] 269@266	2-5300
62-	i [kkjke oYn fdLrgkjke	tKV	249	3-2900
63-	Qh hnoh /k-i- tŷkjke	tKV	268@266	12-8200
64-	cuokjhyky oYn fd'kuyky	ckā.k	230	1-5200
65-	cukjke oYn rktkjke	tKV	56] 129	9-7000
66-	ckyhnoh /ke/ i fRu dukjke	ckā.k	144	4-3500
67-	fcnkehnoh /k-i-	cokjh	256@198	1-9000
68-	Hkøjyky mekukjke Hkhokjke iē x.k /kluk	tKV	33	6-8800
69-	Hkøjyky iē x.ki rjke	ckā.k	275@229	4-2700
70-	Hkøjyky iē ekykjke	tKV	115	12-8900
71-	Hkøjyky iē jkeukjk; .k	ckā.k	109	3-3700
72-	Hkøjyky iē jkeukjk; .k	ckā.k	167	2-5100
73-	Hkøjyky oYn /klukjke	tKV	114	2-6700
74-	Hkøjyky oYn ck/kkjke	l ēkkj	118]119	4-6000
75-	Hkøjyky iē ck?kkjke d	l ēkkj	290@132	8-7000
76-	Hkøjyky Hkxjke gjj [kkjke fi- fyPNjke	tKV	91] 162	4-6300
77-	Hkøjhdøj /k-i- egkohj fl g	jkti w	207	15-7200
78-	Hkøjyky iē /klukjke	tKV	280@95	4-4400
79-	Hkøjfl g oYn ekyfl g	jkti w	151]234]235	12-3700
80-	Hkxorh /k-i- mnkjke	l ēkkj	236]237	12-0200

Ø-I a	dk'rdkj dk uke	tkr	[kljk l ;k	{k-Qy
81-	Hkh[kkjke i ɸ ukjk; .k	tKV	147] 305@148	6-3100
82-	Hkh[kkjke i ɸ exykjke	l ɸkkj	297@172	1-9200
83-	Hkj kjke jkejke v[kkjke i ɸx.k l g'rkjke	eʂknku	259@117	6-9700
84-	ekahyky i ɸ puukjke	tKV	304@247]316@14 9	10-3900
85-	ekahyky oYn l j'tkjke		107]145]192]223	52-2300
86-	ekahykyu i ɸ l j'tkjke	ckā.k	224	3-3400
87-	ekyjke i ɸ jkew	tKV	139	1-5200
88-	ekyjke oYn jkejke	tKV	34]155]164	20-7700
89-	ekyhnoh /k-i- v.knkjke	tKV	267@219	9-3600
90-	ehjk i fRu Lo- ekyjke vknjke] nokjke	tKV	157	3-4300
91-	ekyjke i ɸ vknjke	tKV	205]244	15-2100
92-	ekyjke i ɸ ukjk; .k	tKV	313@111	4-1400
93-	eʂkkjke j[kkjke dkkjke Hkj kjke fi- #/kk	pekj	79	7-4600
94-	ekVkjke i ɸ puukjke	tKV	311@52]314@111] 317@149	12-8200
95-	ekgunkl i ɸ iwknkl	l kk	270@74	5-3800
96-	ekgujkei ɸ i# ij.kkjke	ckā.k	283@64	2-9900
97-	jktey i ɸ ekyjke	tKV	238	5-0900
98-	jkeplnz Jhke ykykjke tBjke	tKV	243	8-9500
99-	jkeirki i ɸ /klukjke	tKV	92	2-8100
100-	jkeirki i ɸ /klukjke	tKV	94] 279@95	4-4300
101-	jkeirki i ɸ /klukjke	tKV	93	1-2600
102-	jke'oj eʂkkjke xɸkukjke] gMɸkukjkr fi- f[kjkt	tKV	206]245	13-2900
103-	jhdkjke i ɸ jkeukjk; .k	ckā.k	191	3-7900
104-	: de.kh i Ruh gfjjke l k; jke grkjke eqhjke i ɸx.k gfjjke l Urq phk	tKV	233	5-8200
105-	: [keknoh /k-i- i Hkjke	tKV	273@211	4-6100
106-	: ikjke ekejkt fi- Jo.kjkt	ckā.k	228] 276@229	5-0600

Ø-I a	dk'rdkj dk uke	tkr	[kljk lē;k	{k-Qy
107-	jōlrjke iē l kgujke	pekj	294@166	3-2200
108-	yknfl g iē ekyfl g	jktiur	150	5-8300
109-	ykljke iē xSjke	tKV	14]126	25-3500
110-	ykljke oYn bZkjke	tKV	186	6-2000
111-	fyPNjke iē l kgujke	pekj	291@113] 295@166	3-2300
112-	fyNe.kjke iē ekykjke	l ēkkj	296@172]299@26 1]301@262	8-2600
113-	'kkārnoh /keZ fRu xh/kkjke	tKV	272@211	4-6000
114-	'kkārnoh iēh ywkkjke	ckā.k	195	3-5900
115-	'kkārnoh i fRu [kha kjke i jrjke ukxjjke Qh h jōrh Hkj h l atw	pekj	26	1-0400
116-	'kkjknōh /k-i- dQkykjke	tKV	2	0-3800
117-	'kkjknōh /k-i- ukjk; .k	cojh	255@198	1-9000
118-	' ; kekjke iē ekgyky	ckā.k	46	7-7600
119-	Jhjke iē f'konku	uk; d	208]212	5-2200
120-	l Urq i fRu ekykjke HkxhjFk dktjke	ckā.k	210	7-1300
121-	l Urq i fRu Lo- ekykjke HkxhjFk	ckā.k	274@229	6-5700
122-	l ghjke iē bZkjke	tKV	102	3-3100
123-	l kōjey vtū vo; Ld iēx.k mnkjke	l ēkkj	169	6-0700
124-	l hrknōh /keZ i fRu jkeyky	l ēkkj	76	3-2900
125-	l ŋjnōh i fRu jkejke Hkōjyky iē jkejke	tKV	57]101	
126-	l j tk nōh /keZ i fRu ywkkjke	ckā.k	197	9-1900
127-	l j tk nōh /keZ i fRu ywkkjke	ckā.k	196	3-5900
128-	l j tkjke iē ghkjke	ckojh	83	4-4700
129-	l j tkjke oYn vknjke	tKV	1]204	14-0600
130-	l kguhnohj /k-i-	tKV	82	2-5300
131-	guēku iē bZkjke	tKV	103	3-3000
132-	gj [kjke oYn bZkjke	tKV	248	9-2800

Ø-I a	dk'rdkj dk uke	tkr	[kljk l ;k	{ls-Qy
133-	g: jke i& f[kjktjke	tkv	231	6-3200
134-	ghjkjke i& vknjke	ckojh	120]121]135	4-2900
135-	gpekjke i& f[kjktjke i& pknk	tkv	201]202	7-7100
136-	foHkxh; k Hkfe&xkpj Hkfe		200	6-3300

d'kd l ph xte blhiky xq kbz j

Ø-l a	dk'rdkj dk ule	tkr	[kl jk l ; k	{le-Qy
1-	vukMfl g gekfl g ukjk; .kfl g t; nofl g fjNikyfl g] iæfl g fi- x.ki rfl g] Hkøjckbz Kluckbz i ƒ-h x.ki rfl g	jktir	45]146]202	23-2600
2-	vukMfl g gæfl g ukjk; .fl g t; nofl g fjNikyfl g] iæfl g fi- x.ki rfl g] Hkøjckbz Kluckbz i ƒ-h x.ki rfl g	jktir	55	2-8300
3-	vej k oYn Mkyw	tKV	12]27]30	50-1100
4-	vkf l g j.kthrf l g] xtfl g] l ƒudøj rkyk] fi- cyollrf l g cƒgc	jktir	50]69	18-9800
5-	mxefl g] pðfl g fi- ukuf l g	jktir	195]269	10-7400
6-	mth.kfl g i ƒ vejfl g	jktir	46]112	13-5000
7-	mekjke i ƒ ghjke mQZgj hjke	tKV	283	2-5300
8-	mekjke oYn gj hjke	tKV	73]106]258]282	23-4800
9-	dj.kfl g i ƒ ekyfl g i ƒ ekyfl g	jktir	267	6-6100
10-	dY; k.kfl g oYn #?kukFfl g	jktir	35]172]184	32-3200
11-	fd'kuf l g i ƒ vejfl g	jktir	115	2-2400
12-	dYi ukjke i ƒ Mkyjke	eðkoakh	79]175	6-6900
13-	dðk fl g i ƒ vejfl g	jktir	114]192	13-4900
14-	dðkkjke Hkøjkyk eykjke fi- pukjke	tKV	315@182] 319@29] 322@134	6-4000
15-	xæknøh /k-i- t; nofl g	jktir	54	8-1700
16-	x.kkfl g oYn Hkøjfl g	jktir	210] 333@277	7-0700
17-	x.kk oYn vej kjke	tKV	257	0-6500
18-	xhrk i frU Lo- dðkkjke jkeyky vtzjke dðkjke dðkyjke ryNkjke nhik fi- dðkkjke	tKV	38]128]189	

Ø-I a	dk'rdkj dk ule	tfr	[kljk l ;k	{s-Qy
19-	xøkukjke oYn pkfkyjke	uk; d	59	8-4100
20-	xudøj [kh x.kskfl g]	jktir	56	4-0700
21-	xkskydøj i fRu Lo= Hkøjfl g	jktir	10]243	17-4100
22-	xkj/kufl g xksUnfl g] txnh'kfl g] i f-x.k	jktir	285	15-9100
23-	xkj/kufl g xkøUnfl g] txnh'kfl g] i f-x.k nøhfl g	jktir	16]43]252]292]293	26-5500
24-	xkj/kufl g i f- nøhfl g	jktir	75]127	12-7000
25-	prjh i fRu Lo- puuk eyk ihfkk ukw l kgu fi- puuk	uk; d	185]187	19-2400
26-	plnfl g oYn #?kukFkl g	jktir	37]61	25-9900
27-	plnfl g oYn #?kukFkl g	jktir	150	1-5200
28-	pufl g i f- f'konkufl g	jktir	36	6-4800
29-	txekyfl g oYn l knyfl g	jktir	120	7-2100
30-	th; kjke l kgyky fd' l ukjke	tKV	301	3-6300
31-	thojktfl g i f- #?kukFk	jktir	151	8-9100
32-	thojktfl g i f- #?kukFkl g	jktir	23]74	17-7400
33-	tS kjke oYn Hkkøkjke	tKV	316@182]320@29]321 @134]329@163	18-4500
34-	Mekjke i f- yk[kyjke	tKV	233	3-9200
35-	rk: jke oYn l jnkjke	ukbZ	102	10-5300
36-	rhtk i fRu Lo= f[kjkt	tKV	21	3-7200
37-	rstkjke i f- iøkjke	tKV	158]285	16-0500
38-	rkykjke oYn exykjke	tKV	235]236]241	15-5500
39-	rkykjke oYn exykjke	tKV	186	5-2200
40-	ngyhnoh /k-i- fd'kukjke	tKV	334@277	1-2600
41-	nmkjke oYn gøpekjke	tKV	173	29-9700
42-	nokjke i f- ghjke	tKV	24]205]223	21-5500
43-	nokjke i wkjke fi- x.kskjke	tKV	217	10-6000
44-	nokjke i wkjke fi- x.kskjke	tKV	8	8-0300

Ø-I a	dk'rdkj dk ule	tfr	[kljk l ; k	{k-Qy
45-	/kluh i Ruh Lo- gtkjhjke fdLrj kjke ekykjke /koi jke >æk egh i jek fi = gtkj hke	tV	13]25]135]145]198]203] 224	53-1700
46-	uhykjke l j tkjke r y Nka deka i nek fi- e?kkjke	tV	5]143]170	21-2600
47-	ikcnkuf l g i e vejfl g	jktir	113]118	13-4900
48-	ij [kkjke i e Hlxokujke	uk; d	225	3-8000
49-	ij [kkjke oYn mekjke	tV	247	6-5400
50-	ij [kkjke oYn Hlxokuk	uk; d	63	5-5700
51-	ij kjke oYn yk[kjke	tV	107]234	15-5900
52-	iæknøh i fRu : ?kkjke	tV	340@324	0-8900
53-	iædøj /k-i- Lo- jøUrf l g] HkS fl g] f'kojktfl g ulnødøj] l qkhyk i e i e=; k jøUrf l g	jktir	200	8-5600
54-	cpuf l g Kkuf l g] x.k'kfl g] fyNe.kfl g fi- Hkøjfl g	jktir	60	5-1700
55-	cgknjfl g i e Hkj kfl g	jktir	66]89]193]250	19-5900
56-	Hkøjhnøh /k-i- eykjke	pekj	71]313@262	11-8500
57-	Hkøjyky i e fl ejFkk] ukFh i fRu Lo- fl ejFkk	tV	108	6-2600
58-	Hkøjfl g i e : ?kukFkl g	jktir	149	10-4300
59-	Hkøjhnøh i fRu Lo- ?ke.Mkjke [kh; kjke	eškoy	256	8-4800
60-	Hkøjh i fRu Lo- ?ke.Mkjke [kh; kjke rkykjke] vkei zdk'k] txnh'ki l kn] i jekjke i e x.k ?ke>Mkjkeljkeh]eyh ryNka i e=; ka ?ke.Mkjke	tV	142]207]245]248	46-0200
61-	Hkh[kkjke oYn mekjke	tV	153]155	9-3100
62-	Hkj k- i wkz i nek fi- xkæl n	yqkj	220	3-6000
63-	Hkj kjke i e Mkyjke	eškø' kh	80]176	8-8500
64-	HkS k dkk l j tk fi- c[krk	tV	117]167]238	32-4800

Ø-I a	dk'rdkj dk ule	tfr	[kljk l ;k	{s-Qy
65-	Hkstkjke i e?kkjke	eškoakh	272	2-5300
66-	e?kkjke fd'kukjke Hkh[kkjke Kkukjke fi- mekjke	tKV	318@182]323@134]32 5@40]326@163	18-5300
67-	ekachnoh /k-i- Hkstkjke	pekj	214]314@262	13-8800
68-	ekachyky oYn gpekjke	tKV	22	5-0600
69-	ekachyky oYn gpekjke	tKV	188	10-9900
70-	ekachyky fd'kukjke fi- [kpekjke	tKV	237	14-9900
71-	ekachyky fd'kukjke fi- [kpekjke	tKV	33	16-9900
72-	ekachyky fd'kukjke fi- [kpekjke	tKV	34	4-9300
73-	ekejkt i e tš kjke	tKV	70	5-0700
74-	ekyh i fRu Lo- l jnkjkjke rk: jke] i ekjke] frtka i e i e = ; ka l jnkjke	ukbZ	166]212	14-9800
75-	eky oYn jkejke	tKV	116	14-4800
76-	ekyjke oYn jkejke	tKV	341@324	2-0700
77-	feJ doj i fRu Lo- vtufi g blufi g txnh'k fl g fd'kufi g ' ; ki kyfl g l jkt doj fi- vtufi g	jktiw	160]260	14-6700
78-	ekyjke jkejke i ekjke fi- vkl g jke	eškoky	81	3-5400
79-	jkeplnz i e /kkkjke	tKV	124]240	20-3100
80-	jkejke i e ckyjke	tKV	11]105]218	18-5500
81-	jkešoj oYn nqk	tKV	165	6-4000
82-	: /kkjke oYn mekjke	tKV	121	5-9900
83-	j ovrjke nUkd i e Hkxokukjke o xkj h i e h Hkxokukjke	jktiw	287	14-6700
84-	yknfi g xawfi g fi- nkufi g	jktiw	126	6-4100
85-	ykyfl g oYn Hkjki fl g	jktiw	65]67]88]194]249	19-6100
86-	ywkjke i e ckyjke	tKV	104]206]213	5-2400
87-	'kadjyky i ekjke dkkkjke ' ; kekjke ekachyky i e x.k ckyjke	ckā.k	86]154	15-7500
88-	'kkirnoh i fRu i j [kkjke	tKV	327@163	5-0600

Ø-I a	dk'rdkj dk ule	tfr	[kljk l; k	{s-Qy
89-	f'konkufi g i f : /kukfk fl g	jktir	242	4-3900
90-	f'konkufi g oYn : /kukfk fl g	jktir	57]72	20-5000
91-	I rkskdøj i fRu Lo- ujirfl g foukn] Hkxokufi g] i f=x.k] ujirfl g] ihdwdøj] deykdoj] i f=; k ujirfl g	tiv	39	10-0300
92-	I rkskdøj i fRu Lo- ujirfl g fouknfl g Hkxokufi g i f=x.k ujifl g ihdwdøj deykdoj i f=; ka ujifrg	jktir	52]64]96]304	16-9500
93-	I Ttudøj i fRu Lo- ekyfil g dj.kfl g jrudoj cufl g] fi- ekyfil g	jktir	157	3-2800
94-	I okbfl g ekafil g ilifil g deydøj enudoj] I k; doj i f i f=; ku ekgufl g	jktir	53]90]159]303	25-0900
95-	I okbfl g] ekafil g] ilifil g deydøj enudoj I k; j doj i f i f=; ka ekgufl g	jktir	208]209	6-0700
96-	I knyfl g oYn ddkyfl g	jktir	44]68	18-3300
97-	I knyfl g oYn eflfl g	jktir	211]298	17-3100
98-	fl jdoj i fRu Lo ukjk; .kfl g	jktir	259]280	11-1900
99-	fl jdoj i fRu Lo- ukjk; .kfl g foðefl g] Kkufi g fi- ukjk; .kfl g	jktir	302	8-4100
100-	I dkjke oYn mekje	tiv	111	8-4200
101-	I kudøj i f h dkufi g	jktir	119	13-4100
102-	I kudøj i f /kdkjke	tiv	125]181]183	20-3200
103-	I tñj i Ruh Lo- fyNe.k e?knhsh i fRu Lo- fyN.k	tiv	266	11-8900
104-	I jtdøj i fRu Lo- tho.kfl g] dj.kfl g jolrfl g] fd'kufi g /kufi g] fi- tho.kfl g Hkøjh ehjk	jktir	20]41]76]178]297	29-9500

Ø-I a	dk'rdkj dk ule	tfr	[kljk l ;k	{s-Qy
	gokdøj eukøjh] Jko.kh i f=; k tho.kfl g			
105-	I jtdøj iRu Lo= tho.kfl g dj.kfl g jøUrfi g fd'kufi g fi- tho.kfl g	jktiur	48	21-2400
106-	I jtkjke fi-eq uRFkkjke	tKV	144]239	21-9300
107-	I jtkjke fi-eq uFkkjke	tKV	148	10-3300
108-	I jbnfi g oYn x.kkfi g	jktiur	62	6-8500
109-	I øVh iRu Lo- ch>kjke [; kyhjke oYn ck>kjke	uk; d	82	4-3000
110-	I kgujke i# 'kjke	tKV	177]219]222]244	45-6400
111-	I kgufi g oYn 'kskufi g	jktiur	49]93	17-5700
112-	I kguhnoh /k-i- e.kkkjke	Hkknw	156	1-0100
113-	ghkjke i# d' jkjke iRu Lo- ekykjke txnh'k l qkjke xSjke fi- ekyk plnw i#h ekykjke	ukbz	99]100]1714]286	21-8600
114-	foHkkxh; &xkpj		229]279	39-6100
115-	f'k{kk foHkkx Ldny		311	1-0100
116-	I koztfud fuekz.k foHkkx		312	0-2900

d'kd l ph xle blhiky l j cMk

Ø-I a	dk'rdkj dk uke	tkr	[kl jk l f; k	{k-Qy
1-	xkok		19]31	3-3900
2-	xkj efdv vkcknh		7	9-0400
3-	vejhnsh /k-i- Hkøjyky	tkv	127	6-3200
4-	mPNodpj /k-i- l okbfl g	jktir	154	23-8200
5-	mPNodøj /k-i- l okbfl g	jktir	146	26-2300
6-	dflkkjke i f tBkjke	tkv	184@40] 187@43	1-4700
7-	djeMkjke i f yknjke	uk; d	105	10-7000
8-	dkstkjke i f ukjk; .k	pekj	193@63	2-4200
9-	[krkjke] jktjke] ukjk; .k]ke fi- ek/kjke	tkv	23]24	17-2500
10-	xakjke i f jkejke	dfigkj	48]136] 159@134	1-27000
11-	x.k'kkjke i f n'kjke	uk; d	18	1-5200
12-	fxj/kkjhyky ek/kjke rkyjke o dkyjke fi- uRFkjke	l qkj	97	7-2800
13-	fxj/kkjfl g i f jkork	njksk	170@129	1-2800
14-	xekudpj] l ekudpj] vuki dpj] rkt dpj	jktir	6	2-8800
15-	xki kyjke i f exyjke	l qkj	117]140	2-9500
16-	xki kyjke] ekujke] gekjke jkejke fi- /klukjke	tkv	45]130	15-2900
17-	xkelhnl i f puohl	Lokeh	84	14-1600
18-	pklnjru i f ukjk; .k	tkv	181@190	2-9600
19-	pph i Ruh Lo-/kejk] elxhyky [krw	pekj	102]109	8-7300
20-	txnh'k i f dkukjke	<kyh	178@39	1-3500
21-	Mkyjke oYn x.k'kjke	tkv	121	8-7900

Ø-I a	dk'rdkj dk uke	tkr	[kl jk l f; k	{s-Qy
22-	fryhdkjke i ƒ Mxkjke	eʒkoá kh	160@21	8-4800
23-	fryhdkjke i ƒ ukʒxjke	<kyh	195@177	2-0300
24-	fryhdkjke i ƒ jkejke	dlqkj	133	2-7800
25-	rstjke i ƒ pukjke	tkV	180@90	3-5100
26-	nhi fnoh i Ruh Lo- ukudnkl fryhdnkl nũkd i ƒ ukudnkl	Lokeh	47] 132	5-8200
27-	nøfl g vkl fl g fi- dj.kfl g	jktir	112	22-4000
28-	nøfl g i ƒ jkefl g	njksk	162@41	1-6900
29-	ujl kjke i ƒ tBkjke	tkV	183@40] 186@43	2-7500
30-	ujl kjke] jkepln] dkkjke 'kjke fi- tBkjke	tkV	49]50]51]137	27-3800
31-	ukujke i ƒ x.kkjkjke	tkV	122]139	8-9700
32-	ukjk; .kh i Ruh Lo= jkefl g	njksk	163@41	1-6900
33-	uki fl g i ƒ jkefl g	njksk	166@41] 168@124	1-3800
34-	iješojh nøh i Ruh x&kjke	dlqkj	135	2-7800
35-	iġ [kjke i ƒ ekykjke	tkV	103	6-1700
36-	i ġi knøh /k-i- Jo.kdøkj	iztkir	158@134	2-0200
37-	i eknoh /k-i- eʒkjke	tkV	10	5-0500
38-	c'khyky i ƒ ywkjke	ckã.k	101	3-8700
39-	cxl kle i ƒ ekykjke	uk; d	190@80	2-4600
40-	lkøjfl g i ƒ jkefl g	njksk	165@41] 167@124	1-6900
41-	Hkjke i ƒ ukʒxjke	<kyh	194@177	2-0300
42-	Hk fl g i ƒ jkork	njksk	171@129	1-2800
43-	enufl g i ƒ jkor	njksk	173@129	1-2800
44-	enufl g oyn ikankufl g	jktir	148	13-6600
45-	eukʒjh i Ruh ?kl hjke	uk; d	191@180	2-4600
46-	ekxhyky i ƒ pukjke	tkV	42@126	15-0800

Ø-I a	dk'rdkj dk uke	tkr	[kl jk l f; k	{ls-Qy
47-	ekxyky i f l j tkjke	ckā.k	118	2-4400
48-	ekxyky] xki kyjke] jkesoj txnh'ki d kn fi- ekshjke	ukbz	106	5-2900
49-	ekyfl g i f jkork	njksk	169@129	1-2900
50-	ekykjke gækjke Hkxokukjke jølrkjke ukujke fyNe.kjke 'køjyky fi- cxjke	l fkkj	22]113	8-5200
51-	ekykjke ywkkjke fi- x.ki rjke	l fkkj	116@142	2-5000
52-	ewkjke i f ukj; .k	tkV	182@90	2-9700
53-	ekv/kjke i f pøjke	tkV	179@90	2-4200
54-	ekv/kjke i f ewkjke	l fkkj	115	68-0900
55-	ekshjke] Åpkjey fi- idk'key	dlfgkj	58	6-4900
56-	ekshfl g jkefl g	njksk	164@41	1-6900
57-	ekguh i fRu Lo- i ukjke	eškoākh	128	8-0800
58-	ekguh i fRu Lo- i ukjke	pekj	5	22-4100
59-	jkeplnz i f tBkjke	tkV	188@43	2-2100
60-	jkeplnz i f uRFkjke	<kyh	174@39	4-0600
61-	fjNekyfl g i f jkork	jktir	172@129	1-2800
62-	: [keknøh /k-i- fd'kukjke	tkV	125	0-3200
63-	: [khnøh i fRu Lo- ekgujke ukj; .kjke : ?kjke fyNe.k ekxyky fi- ekgujke 'kjaekyh l kguh i f=; ka ekgujke	tkV	120]138	8-9600
64-	j fkkjke Hkkuhjke i f Hkkuhjke	uk; d	94	7-5900
65-	jølrjke i f ukj; .k	pekj	192@63	9-3000
66-	ykyfl g] ukxj fl g] Hkøjfl g] fi- igykn fl g	jktir	111	2-0200
67-	fyNe.kjke] ghjkjke fi- ekshjke	tkV	46]131	6-4400
68-	fot; døj i fRu] t; fl g mQZ t l olr fl g] blnzthrf l g x.kkfl g rstekeyfl g fi- t l fl g	jktir	12	6-1000

Ø-I a	dk'rdkj dk uke	tkr	[kl jk l f; k	{ls-Qy
69-	foeyk dpj i Ruh Lo- Hkøjfl g	jktir	147	1-1600
70-	'kkUrh nsh i e-h ywkkjke	ckā.k	100	3-2400
71-	'kjkjke i e tBkjke	tkV	185@40	2-2100
72-	' ;kekjke i e dukjke	<kyh	175@39	1-3500
73-	I tuknsh /k-i- j[kkjke	uk; d	17	2-8800
74-	I okbzfl g] enufl g] rstfl g fi- i kcnkufi g	jktir	110	20-3700
75-	I okbzfl g] enufl g] rstfl g fi- i kcnkufi g	jktir	4]143]145	17-8000
76-	I hrkjke i e ekykjke	uk; d	189@80	2-4500
77-	I øjkjke i e ekfjke	iztkir	98	11-6900
78-	I ksk i Ruh Lo- Mkyjke] i nekjke] th; kjke] gj thjke]Mpxjjke fi- Mkyjke] Hkøjh ykyh] jktw i e=; ku Mkyjke	uk; d	96]99	12-7300
79-	I kgujke i e nhi kjke	clfgkj	52	16-4100
80-	ghjkjke i e I jtkjke	uk; d	20	4-3000
81-	ghjkjke] i llukyky] ykyjke xkælnjke] clfn.key fi- guæku ukFkh i Ruh Lo- guæku	clfgkj	53	17-0200
82-	gk'k; kjfl g i e tlf g	jktir	38	13-5100
83-	xke i pk; r blnikyl j I k[kyku		44	3-7900
84-	xke I ekt }kjk pjkbzo vl; iz kstuk; ka dsfy, j [kh xbzHkfe		1] 13	1-1300
85-	jkt dh; mPp i kFk- ckfydk fo ky; blnikyl j I k[kyku		2	2-0200
86-	jkt dh; i kFkfed fo ky; dkyjk tkgM+		161@21	0-1300
87-	I kozt fud fuekz k foHkx		123]141]144	8-6700

d'ld l ph xte gFlk.k %luniky cMk½

Ø-l a	dk'rdkj dk ule	tkr	[kl jk l ½; k	{k-Qy
1-	fl ok; pØ ukdfcy dk'kr tkgMik; ru		10]47]82]83]103] 155]156	11-7200
2-	vthrfl g HkxhjFkl g fi- tho.kkl g	jktir	128]138]193	47-2600
3-	vknyke i ½ : ikjke	jsxj	67	4-3800
4-	vkI hnoh i Ruh Lo- nqkjke] gykl kjke] i qkjke] mnkjke] blntjke fi- nqkjke] Hkøjh noh] pkuk noh	tkV	69	18-9400
5-	bZkjke] ekvkjke] jktjke i rjke fi- jðlrjke] irkl h] fcjek] l jcrh	uk; d	130	11-9300
6-	mPNdøj i Ru Hkjfl g flk[kfl g	jktir	73	4-9300
7-	mnkjke i ½ vukjke	dfigj	93]97	24-5700
8-	mnhnoh /k-i- i jrjke	tkV	53	5-8900
9-	mekjke i ½ l øjke	tkV	61	6-5100
10-	mekjke i ½ l øjke	tkV	44]45	15-0700
11-	dklrrnoh /k-i- jkenø	tkV	15	4-7700
12-	dkyjke xki kyjke] eukst døkj i ou døkj fi- fd'kukjke	tkV	135	30-0100
13-	dkyjke] xki kyjke] eukst døkj] i oudøkj fi- fd'kuyky	ckā.k	126	37-5000
14-	dkyjke i ½ l økukjke	eðkoky	63	2-1000
15-	fd'kukjke i ½ ckykjke	dfigj	157	1-4400
16-	fd'kukjke] vkclkj] ywkjke] fcxkjke] dkstjke fi- rkykjke	eðkoakh	20	15-1500
17-	dqkkyfl g i ½ gjfl g	jktir	124] 125	13-6800
18-	dskjnøh i Ru 'kjke jktfl g] Hkxokuf] Hkæfl g fi- 'kjke	jktir	108]115	27-2600
19-	dskjke i ½ /klukjke	tkV	99	5-6000
20-	dskkjke i ½ i øjke	tkV	7	4-5000

Ø-l a	dk'rdkj dk ule	tkr	[kl jk l ;k	{ls-Qy
21-	dkstkjke i � ukjk; .k	pekj	54	6-8900
22-	[k�kjke i � mnkjke ekguhnoh i fRu [k�kjke jkeno i � [k�kjke	tKV	23	13-3600
23-	x.kifl g i � ekgufl g	jktir	173@98	7-0900
24-	fxj/kkj hjke ekv/kjke rkyjke dkyjke i �x.k uFkkjke	l �kj	119]120	12-2300
25-	xki kyjke i � eakykjke	l �kj	2	5-6700
26-	xki kyjke] gjhke fi- Kkukjke	dfigkj	94	15-0900
27-	xkelnnky i � pwnku	dke	110]111]117	25-0800
28-	xkelnnkl i � pwnkl	uk; d	64	5-6900
29-	?kkl hjke i � ekykjke	uk; d	178@30	21-700
30-	pku.ey d�.key fi- ckkyjke	dfigkj	40	6-9400
31-	p�hnoh i fRu Lo- pEi kyky	dfigkj	154	3-9000
32-	p�h i fRu Lo= Hkkuhjke o l kgujke i � Hkkuhjke	dfigkj	89	5-8800
33-	pukjke xSijke fi- fujk; .k	jsj	68	7-2600
34-	txnh'k i � dkukjke	<kyh	170@116	1-9200
35-	txekeyfl g i � inefl g	jktir	144	20-1100
36-	txekeyfl g] dj.kfl g fi- inefl g	jktir	127	25-4900
37-	tMkodpj i fRu txrfl g Hkxfl g ukjk; .kfl g fi- l xrfl g l Urkskd�j jkt��j Kkud�j i �=; ka l xrfl g	jktir	55	5-0600
38-	teukd�j i fRu Lo- e�kfl g	jktir	134	26-5800
39-	t; ukjk; .k i � gtkjhjke	dfigkj	86]90	11-5900
40-	t�kj fl g i � ekgufl g	jktir	174@98	7-0800
41-	tBkjke i � fd'kukjke	tKV	36	5-8500
42-	tBh i fRu pku.kjke	dfigkj	162@88	7-3500
43-	Kkukjke i � ukuxjke	dfigkj	143]159	12-2400
44-	Mkyjke oYn x.kkkjke	tKV	16]112	12-6100
45-	Mkjke i � xkelnjke	dfigkj	72]85	14-5800

Ø-l a	dk'rdkj dk ule	tkr	[kljk lē;k	{ls-Qy
46-	frykdjke iē Mxjjke	eškoá kh	46	8-0900
47-	frykdjke iē Mxjjke] fdI kukjke] vkdkjey] ywkjke] f[ka kjke] dkstjke fi- rkyjke	eškoá kh	32	9-8800
48-	frykdjke iē uhjxjke	<kyh	180@169	2-8800
49-	frykdjke iē gtkjhjke	dfigkj	81	8-9600
50-	ryNkjke] ekgujke] prujke] cdkjke fi- pukjke	jsxj	65	5-2600
51-	ry/Nh i fRu Lo- th; kjke] Hkøjyky] ctjxyky fi- th; kjke	ckā.k	26]28]70]96]102]11 3	52-1800
52-	ryl hnl iē ?ke.Mnl	Lokh	118	16-8400
53-	nkujke] dēHkkj fi- pukjke	dfigkj	78]147]153	26-8100
54-	nokjke] Hka; kjke fi- frykdjke	uk; d	49	4-5700
55-	ukxjey iē ywkjke	ckā.k	58	4-9300
56-	ukuw i fRu Lo- l g tkjke] Hkøjkjke]VkkMkjke jktjke fi- l g tkjke] jkel; kjh] ftaw i ē=; ka l g tkjke]	eškoá kh	34	8-5000
57-	ukuwjke oYn x.kškkjke	tkV	17	1-3300
58-	ukšxjke] eškkjke iēx.k Jherh puhnoh /kež Ruh i g [kkjke	tkV	8	6-0700
59-	ukšxjke] eškkjke fi- i g [kkjke	tkV	21]37]38	38-9300
60-	i lufi g iē ywkl g	jktir	140	6-3200
61-	i pjkjke] prujke] js[kkjke fi- Hkkuhjke	uk; d	123	4-3700
62-	i g [kkjke fd'kukjke fi- ekyjke	y[kkj	13]101	19-2600
63-	i g [kkjke fd'kukjke fi- ekyjke	y[kkj	9]11]12	11-8900
64-	i g [kkjke iē fgerkjke	tkV	39	5-6900
65-	i g cjke] dkujke] Hkxhjke] cskjke] vtžjke fi- uRFkkjke	eškoá kh	52	11-9300
66-	i Hkjke iē tš kjke	tkV	141]142	6-5600
67-	i Hkjke oYn x.kirjke	tkV	2]4	11-1300

Ø-I a	dk'rdkj dk ule	tkr	[kl jk l ; k	{k-Qy
68-	Qw kjke i ɸ mekjke	dfigkj	152]160	22-7700
69-	cj'khyky] [kɸkjke] l kgujke] ukjk; .kjke fi- mth.kkjke	ukbz	22]29]95]129	23-5500
70-	ctjakyky i ɸ ewkjke	dfigkj	164@136	0-9500
71-	cknw i fRu Lo- ješoj] ?kl hjke i ɸ jkešoj	l fkkj	151]	4-6900
72-	ckyjke i ɸ x.kskjke	dfigkj	145	3-4600
73-	cdkkjke i ɸ exykjke	l ukj	1	4-2200
74-	cxkjke i ɸ ekykjke	uk; d	176@30	2-1700
75-	Hkøjfl g i ɸ irkifl g	jktir	76	1-8100
76-	Hkøjyky i ɸ ekykjke	tkV	56]75	4-9700
77-	Hkøjhnoh /k-i- ngtkjke	dfigkj	161@188	7-3500
78-	Hxokujke i ɸ ekyjke	dfigkj	87	7-9900
79-	Hkhokjke i ɸ ekyjke	dfigkj	107	13-1500
80-	Hkjfl g i ɸ xkelnfl g	jktir	77	3-1200
81-	Hkj kjke nUkd i ɸ nsA i fRu vkl kjke	ckä.k	27	3-7600
82-	Hkj jke i ɸ ukšaxjke	<kyh	179@169	2-8700
83-	Hkj kjke i ɸ ekš/kjke	tkV	42	7-2600
84-	Hkš kjke mnkjke egujke fi- ukujke	ešokoy	14	16-6100
85-	exst døj /k-i- Lo- dškjhf l g ctjæfl g] Joufl g] dkuf l g] rst i kyfl g] i æfl g] i ɸ x.k dškjhf l g	jktir	57]74]76	4-8300
86-	e?kkjke i ɸ dkukjke	<kyh	168@116	1-9200
87-	eyjke i ɸ ghjkyky i ɸ dškj kjke	dfigkj	146	21-1900
88-	ekxhyky i ɸ vukjke	tkV	131]132]133	22-0100
89-	ekxhyky <kyjke fi- t; dj.kkjke	jsxj	62	5-4400
90-	ekxhyky i ɸ xækjke	dfigkj	167@136	1-9000
91-	ekujke pškjke fi- i ækjke	ešokoy	60	9-8700
92-	ekyjke i ɸ xkelnjke	dfigkj	71]84	14-5900
93-	ekyjke i ɸ ryNkjke	tkV	79	7-9100

Ø-I a	dk'rdkj dk ule	tkr	[kljk lē;k	{s-Qy
94-	ekykjke iē /klukjke	tKV	51	6-3200
95-	ekykjke iē cxjke	l fkkj	137	6-8800
96-	ekykjke gøjke Hkxokujke jøllrjke] ukujjke] fyNe.kjke] 'køjyky] fi- cxjke	l fkkj	19	15-0400
97-	ekguh i fRu Lo= dukujke] fd'kukjke	dfigkj	149	6-0800
98-	jkeplnz iē uRFkkjke	<kyh	172@116	5-7500
99-	jkeirki] nykjke guøku fi- fdl ukjke : [kek] i fRu Lo- fd'kukjke	tKV	35	7-7000
100-	jkorkjke inekjke fi- gplekjke	tKV	41	21-9400
101-	: Nknøh i fRu ekgujke ukjk; .kjke : ?kkjke fyNe.k ekahyky 'kjk	ekyh	18	1-3400
102-	: ?kfl g iē ekgufl g	jktir	175@98	7-0800
103-	yk?kjke iē ekVkjke	tKV	43	5-6200
104-	ykyjke iē fcMnkjke		148]150	25-0800
105-	ykyjke iē chMnkjke	dfigkj	80	4-5000
106-	fy[kehpln iē iøkjke	dfigkj	158	5-6800
107-	fyNek i fRu Lo- l økukjke Vhdjke dkyjke fi- l økukjke		33	14-3900
108-	fyNek i fRu Lo- l økukjke] Vhdjke] dkyjke] fi- l økukjke	eøkoåkh	50	10-1800
109-	fyNeknøh /k-i- mnkjke	dfigkj	92	11-2900
110-	fo knøh iēh ywkjke /k-i- enuyky	dfigkj	91	5-0600
111-	'kijnkl iē iwkhkl	Lokeh	122	9-9400
112-	'kijnkl ekgunkl	Lokeh	121	0-0100
113-	'kijnkl] ekgunkl fi- iwkhkl	Lokeh	114	9-0700
114-	'; kekjke iē dukjke	<kyh	171@116	1-9200
115-	Jo.kjke iē eykjke	dfigkj	165@136	0-9500
116-	l køjey iē Hkøjyky	tKV	100	5-6000
117-	l kørkjke oYn rktkjke	eøkoky	109	6-7900

Ø-I a	dk'rdkj dk ule	tkr	[kl jk l ;k	{s-Qy
118-	I kfo=h nsh /k-i- ijekjke	tV	5]6	5-8500
119-	I hrkjke i# ekykjke	uk; d	177@30	2-1700
120-	I kuknsh i fRu Lo- jkorkjke	e8kjkt	66	4-3700
121-	I qkhyk i fRu Lo- tBey jkds k A"kk	jsj		4-3700
122-	I kguyky i# xakjke	dfigj	166@136	1-9000
123-	gykl kjke i# ywkjke	dfigj	163@136	1-8900
124-	xke I ekt }kj k pjkbo vl; i z kst ukvka ds fy, j [kh xbz Hkfe		48]105]106	8-4700
125-	jkt dh; i k Fkfed fo ky; bli nky l j		104	0-8100

d'kd l ph xle dY; k.kl j

Ø-I a	dk'rdkj dk uke	tkr	[kl jk l ;k	{ls-Qy
1-	vpkjke i i j [kkjke	ckā.k	101]330]427]428]429	29-4800
2-	v.kphnōh /keĭ Ruh Lo- xykjke jkeš o jky fd'kukjke i x.k xykjke	tkV	187]392	11-3600
3-	vej jke oYn inekjke	tkV	28]241]483] 491	33-2500
4-	vej h i Ruh Lo- ekgyuky l ghjke rkyjke l rkkdekj i x.k ekgyuky	l ūkj	17	4-1000
5-	vtūjke i ukujke	eškoky	220]444	6-5100
6-	vtūjke i i wjkke	eškoky	424]406	11-8400
7-	bz kjke i rtkjke	tkV	13	4-0400
8-	bz kjke i cdkjke	tkV	31]311]478	12-0300
9-	mnjktjke] i ekujke] pškjke fi- x.kškjke	tkV	53	5-3100
10-	mnjke i jkork	tkV	398]442	13-8000
11-	mnjke Qk jke i x.k [l rkjke	tkV	59]171]437] 506@59	19-0500
12-	mnk i iluk	ukbZ	358	6-3100
13-	mehnōh i Ruh Lo- eškjke dkukjke nŪkd i eškjke	eškoky	196]452]467]l Me]458	17-2600
14-	deyknoh /k-i- Hkōjyky	tkV	517@23	1-0100
15-	deyknoh /k-i- Hkōjyky rkyjke i Hkōjyky	tkV	518@23	8-3400
16-	dkyjke v'kkd dekj i x.k ekyjke	tkV	228	7-0000

Ø-I a	dk'rdkj dk uke	tkr	[kl jk l f; k	{ls=Qy
17-	dkyjke i f Qh kjke	uk; d	15	4-69000
18-	fd'kukjke i f Hkha kjke	tkV	173]270]441	29-7800
19-	fd'kukjke i f Hkha kjke	tkV	153	4-0300
20-	fd'kukjke i f Hkj kjke	ckā.k	103]1104]10 5]106]108	11-4700
21-	fd'kukjke i f gækjke	tkV	122	0-7600
22-	fd'kuh i f h [; kyhjke	eskoky	487	5-2700
23-	fd'kuhnøh /k-i- jkeplnz	tkV	376	5-3700
24-	fd'kuhnøh i Ruh Lo- i wkjke Hkøjyky jkedj.k i j l kjke i f x.k i wkjke	tkV	345	16-5200
25-	fdLrjh i f Ru Lo- Qh kjke	tkV	297	12-9600
26-	dkkkjke i f fy[kjke	eskoakh	102	2-1000
27-	dškj i f Ru Lo- ohjcy	<k<h	130]313	5-1200
28-	dškjnoh /k-i- l j tkjke	tkV	377	5-3100
29-	dškjnoh i f Ru Lo- ekgujke jkeirki i f ekgujke	tkV	110	16-0100
30-	dškkj i f ekM+	eskoakh	118	3-8400
31-	dškjke i f xskkjke	uk; d	493]516@4 82	10-2900
32-	f[kā k i f yPNk	tkV	219]492	9-1900
33-	f[kjkt i f fd'kukjke	tkV	5]6	5-4600
34-	[krkjke f[kjktjke i f x.k ufkjke	eskoky	195]403	21-6000

Ø-I a	dk'rdkj dk uke	tkr	[kljk l f; k	{ls-Qy
35-	[krkjke l xukjke i lukjke yukjke i f x.k : i kjke	eškoky	175]263	12-9000
36-	xak i fRu Lo- ekykjke o Jhjde vk'kkjke jktkjke i f x.k ekykjke	tkV	402	2-8700
37-	x.ki rjke i f tš kjke	tkV	234]348	11-2400
38-	x.ki rjke i f ekujke fxj/kkj i f ykyjke	eškoky	352]471	19-3900
39-	x.kkkjke i f Hkkkjke	tkV	367	4-6700
40-	xhrknøh /k-i- tLl jke	tkV	363	7-5900
41-	xyhnoh /k-i- jkeirki	tkV	307] dŷk] 308	3-2900
42-	xki kyjke i f mnkjke	tkV	451	300
43-	xki kyjke ekykjke gLrq i liwl kguh l f u dfork i f i f; ka gj thjke fyNek i fRu Lo- gj thjke	eškoky	539@272] 540@440	5-4100
44-	xki hjke i f Lo- prjknøh i fRu ekMjke	tkV	183] 508@183	5-9900
45-	xkørhnoh i Ruh Lo- vki jke Hkøjyky 'kj kjke i hjkjke l ghjke epdukjke i f x.k vki jke	eškoky	134]484	4-3800
46-	xkfolnjke nŷkjke fi- : i kjke		291	7-0600
47-	ykyh ekyh fi- yk/kjke fgjk i fRu Lo- yk/kjke	ukbZ	410	6-7600
48-	xkfolnjke i f dškkjke	tkV	435	7-5500
49-	xkfolnjke i f : i kjke	ukbZ	162]453]454]455	11-6600

Ø-I a	dk'rdkj dk uke	tkr	[kl jk l f; k	{ls=Qy
50-	prjk i f plnz	uk; d	286	2-9100
51-	prjkjke rk: jke ghjkjke Hkj kjke tkkkjke chjcyjke xknkjoh i f i f=; ku xsukje	eskoky	400	4-8700
52-	phok i frU Lo- Qj l k] fd'kukjke] [krkjke] ekahyky] Jhjke] puukjke] fi- Qj l k	tkV	250]445	10-1300
53-	puhyky i f l fnjkl	Lokeh	128	6-6700
54-	puh i frU jkAjked	tkV	381	7-5900
55-	prujke i f gjjke	tkV	326]l Mcl3 27] 545324]548 @325	2-4400
56-	puukjke oYn Vhdjke	tkV	91	4-7400
57-	Nxuukfk puukfk i f x.k pdukfk	fl)	530@56	7-5900
58-	tMko i frU Lo- pdkjke	ukbz	129]447	13-4700
59-	t; ukj; .k i f Hkj kjke	ckā.k	448	7-2800
60-	t l jke i f Mxkjke	tkV	385]379	3-0800
61-	t l knk i frU Lo- Jo.kjke	eskoakh	202]247	8-3700
62-	tLl jke i f Mxkjke o xhrk noh /k-i- tLl jke	tkV	371	6-5100
63-	thomoh i frU Lo- fdLrj kjke	tkV	74]76]479]5 02]507@76	33-2500
64-	tBkjke i f xkellnjke	eskoky	541@440	2-8300
65-	tBh i frU Lo- ekyk] jktsoj] f'koyky] HkxhjFk] l [kkjke] g: jke fi- ekyk	tkV	51]239]301] 389]399	31-3800

Ø-I a	dk'rdkj dk uke	tkr	[kl jk l f; k	{ls-Qy
66-	tBhnoh /k-i- ekykjke	tkV	331] 512@331	6-1600
67-	tshnoh /kei fRu Hkjkjke	eʃkoakh	264	2-1400
68-	tš kjke i ɸ eykjke	eʃkoakh	138	3-1500
69-	tʃknoh i fRu Lo- l ktujke ekMijke jkeʃojyky l kguyky l ghjke tkyjke	tkV	77]dɸ/k] 78]176]300	26-3700
70-	tš kjke ekykjke Mkykjke ekgykyk Qj l kjke]Hkøjh pɸfkh o /kki w i ɸ i f; ka eykjke	eʃkoky	85]501	17-8700
71-	>eh i fRu Lo- i w kjke] jkeukjk; .k i ɸ i w kjke	tkV	315	7-950
72-	Mkyjke i ɸ fyNe.kjke	eʃkoky	198]200	7-4100
73-	Mkyjke]dHkjk] rkykjke] l ɸukjke] ekyjke] dš kjjke fi- fyNe.kjke	eʃkoakh	119]477	13-0900
74-	ryNkjke i ɸ jš kjke	tkV	349	8-8900
75-	ryNh ekMh xš k l j tk i f; ; k y w kjke	tkV	137]232]495	20-5100
76-	rkykjke i ɸ tš kjke	tkV	90]391] 520@341	37-4400
77-	rkykjke jkeyky	tkV	69]70]l Mɸ] 71]342	22-5400
78-	rkykjke oYn Hkš kjke	ckā .k	109	9-7900
79-	rkykjke] eʃkjke fi- l ɸukjke	eʃkoakh	120	3-8300
80-	nɸkjke i ɸ nkukjke o fd'kuh i ɸh [; kyhjke	pekj	225	8-1000
81-	'kk[kk i w jkl j	eʃkoky	262]488	18-7200

Ø-I a	dk'rdkj dk uke	tkr	[kl jk l f; k	{ls=Oy
82-	nykjke i ɸ gj [lkjke	tkV	199	3-1900
83-	nykjke] jkešoj] fd'kukjke fi- ukjk; .k	tkV	115]223]284]503	30-0300
84-	/k/ħnɔh /keʔ fRu Mkyjke	eʃkɔky	246	3-2400
85-	uRFkh i ɸh jkeyky	tkV	375	10-1200
86-	uRFkjke i ɸ eʃlkjke	tkV	48]49]l Mɔl] 50]226]356	25-4500
87-	ukFħnɔh /keʔ fRu Lo- ukudjke xkj/kujke Jhjke jkedj.k tho.kh i ɸ i ɸ=; ka ukudjke	uk; d	33	6-9100
88-	ukud i ɸ Hkxoku	uk; d	211	2-7300
89-	ukujke vejke i ɸx.k /klukjke	eʃkɔky	500	4-2400
90-	ukujke i ɸ /klukjke	eʃkɔky	66	3-5200
91-	ukujke i ɸ /klukjke	eʃkoakh	237	4-3000
92-	ehjknɔh /keʔ i fRu ješojyky	tkV	382	7-8400
93-	inekjke oYn iækjke	eʃkɔky	24] 505@24	5-7700
94-	i lukyky i ɸ ghjk	tkV	249]413]414] l Mɔl] 415	13-1900
95-	i luh i fRu Lo- jølrkjke i hdjjke		499	6-2200
96-	i luhnɔh /k-i- x.kskjke	tkV	549@52	3-7900
97-	ijekuukFk oYn pkyukFk	fl)	529@56	3-3700

Ø-I a	dk'rdkj dk uke	tkr	[kljk l f; k	{ls-Qy
98-	ihjkje oYn mnkje	tkV	190]d\k]19 1	7-0500
99-	i uuhnoh /k-i- x.k'kjke	tkV	549@52	3-7900
100-	i wkkjke i f nkukje	ckā.k	100	4-8000
101-	ihk i f uFk	tkV	329]433	10-3600
102-	igykn i f vejke	tkV	380	5-0600
103-	Oh kjke i f tš kjke	tkV	94	6-3000
104-	ctjakje xki kyje fd'kukje yPNhjke vkei dk'k fi- ukFjke	ckā.k	83	8-5000
105-	kyhnoh /k-i- f'koyky ghjk noh /k-i- ?ku'; ke l jLorh noh /k- i- gfjke	tkV	550@52	3-8000
106-	kyhnoh i Ruh f'kyky ghjk noh i fRu ?ku'; ke l jLorh i fRu gfjke	tkV	524@45]52 6@46]528 @47	2-9000
107-	kyhnoh i fRu f'koyky ghjknoh i fRu ?ku'; ke l jLorh	tkV	523@45]52 5@46	2-9000
108-	chjk i fRu Lo- Vhdwo prujke i f Vhdw	tkV	337	7-3100
109-	c/kjke i f i wkkje	eškoky	243]407	11-8500
110-	Hkøjyky chjcyjke fi- gæjkt	eškoakh	201	5-1100
111-	Hkøjyky oYn i wkkje		95	8-2200
112-	Hkøjhnoh /k-i- ekahyky	tkV	338	10-4600
113-	Hlxokujke i f rgyNkjke	l ukj	218	3-6100
114-	Hkxhj Fk i f jkeirki	tkV	544@486	3-8550

Ø-I a	dk'rdkj dk uke	tkr	[kl jk l f; k	{ls-Qy
115-	Hkk: jke i ɸ xh/kkjke	tkV	7	5-4800
116-	Hkh[kkjke i ɸ gj thjke	tkV	546@324]5 47@325	2-4400
117-	Hkj kjke i ɸ xk/kkjke	uk; d	513@314	1-5200
118-	Hkj kjke i ɸ xk/kkjke	uk; d	35	8-0100
119-	Hkj kjke i ɸ plntjke	uk; d	8	3-0900
120-	Hkj kjke i jkjke fi- vknjke	eʃkoá kh	212]265]497	12-7000
121-	Hkš kjke i ɸ prujke	tkV	149]l Mə]3 03]534@15 0	15-9500
122-	Hkš kjke i ɸ prujke i ɸ prujke	tkV	116]302	12-2600
123-	extjhje i ɸ tho.kjke	eʃkoky	535@215]5 37@272	5-6500
124-	er i fRu Lo- x.kš kjke jkeplnz Hkj kjke fi- x.kš kjke	tkV	351	11-0500
125-	enuyky l hrkjke jkeirki jkešojyky gfjjke i ɸ x.k ekykjke	ukbZ	140] 343	8-7600
126-	eukgjhnoh /k-i- ekgujke	tkV	193	9-0400
127-	eukgjhnoh i fRu Lo- mn; 'kədj pəkjke jkefd'ku Hkəjyky i jek fi = mn; 'kədj	tkV	396]397	11-0800
128-	egkohj] uehpln i ɸ x.k gj [kkjke	ckā.k	131]233]481	17-2300
129-	ekəhyky i ɸ Hkxokujke	uk; d	16]88	18-8800
130-	ekəhyky l ghjke i ɸ x.k ukjk; .kjke	tkV	127	11-6800
131-	ekəhyky l ghjke i ɸ x.k ukjk; .kjke	tkV	336	10-8100

Ø-I a	dk'rdkj dk uke	tkr	[kljk l f; k	{ls-Qy
132-	ekaxyky l ghjke i f x.k ukjk; .kjke	tkV	174	10-1000
133-	ek.kd i f i ek	eʃkoá kh	136	6-2100
134-	ek.kd i f i ek	eʃkoá kh	203]474	15-3300
135-	ekuh i fRu Lo- fc'kukjke	eʃkoá kh	401	10-4100
136-	ekykjke i f xakjke	tkV	159]160	4-3500
137-	ekykjke i f xykjke	tkV	188]310	11-1400
138-	ekykjke jkejke ctjaxyky mnkjke ykykjke eukgjh 'kkfUr deyk i f i f=; k Lo- pukjke	ckā .k	87]360	8-4000
139-	ekykjke] tš kjke] rgyNkjke] Hka; kjke dtkkjke] l kgujke] jølrjke] f'kodj .k Jhjke fi- ekfrjke	l fkkj	73]490	17-5100
140-	ekykjke] i jrjke] jkej [k fi- vtū	tkV	167]168]240]355	19-6900
141-	ekyh i fRdu L- vejkl Hkøjyky] l Urkšk fi- vejkl	tkV	395	3-6200
142-	ekyh i fRu Lo- vejkl Hkøjyky] l Urkšk fi- vejkl	tkV	248]416]446	15-7100
143-	ekyw i f cdkk	tkV	30	3-7200
144-	ekyw i f Hkkrekt	tkV	26]27]121	16-7200
145-	ekyw i f yknw	tkV	20]462]465] 466	14-4900
146-	ekyq i f 'kkyw		58]439	13-7900
147-	ekyq dš kjh] fi- [køk	tkV	217]353	13-2900

Ø-I a	dk'rdkj dk uke	tkr	[kl jk l f; k	{ls-Qy
148-	ekyjke i ƒ l kyjke	tkV	438	1-3400
149-	ekyjke oYn Hkkjrkjke	l fkkj	75	8-7200
150-	eykjke ulnyky i ƒ x.k njktjke	tkV	96]144]145] l Md]146	9-6500
151-	eykjke i ƒ x.k kjkjke	eškoky	224]255]489	15-8600
152-	eykjke i ƒ plnkjke	uk; d	287	2-9100
153-	eykjke i ƒ ukujke	eškoky	221]443	6-5200
154-	ešk i ƒ tš k	tkV	97	4-2900
155-	eokjke jrjke fxj/kkj i ƒ x.k ekgujke	tkV	194]421]422	11-3400
156-	ekvkjke i ƒ tho.kjke	tkV	364	5-0600
157-	ekvjke i ƒ xykjke	tkV	386]388	9-8200
158-	ekMhndh /k-i- eaykjke	uk; d	10	3-1000
159-	ekMjke i ƒ xykjke	tkV	189	2-6600
160-	ekMjke i ƒ /klukjke	tkV	385	16-1100
161-	ekMjke i ƒ Hkk: jke	tkV	107]411	21-5200
162-	ekMjke i ƒ ekgujke	uk; d	285	11-0800
163-	ekMjke i ƒ Jhjke	tkV	459]460]l M+ d]461	7-2700
164-	ekMjke i ƒ gækjke	tkV	123]334	10-3400
165-	ekrhjke i ƒ xakjke	tkV	93]476	19-3000
166-	ekgujke i ƒ xkelljke	eškoky	538@272	2-9700

Ø-I a	dk'rdkj dk uke	tkr	[kljk l f; k	{ls-Qy
167-	ekguh i fRu Lo- mnkjke] Hkøjyky] ekvkjke rk: jke] vk'kjke fi- mnkjke	eškoákh	207	6-8900
168-	jktifrnøh /kei fRu oñ izdk'k	tkV	235	6-3000
169-	jktk i fRu Lo= Mpxj grjke l ghjke eU'kkjke fi =- Mpxj	tkV	163]464]l M+ d]470	15-8600
170-	jkedj.k eokjke fi- l j tkjke	tkV	151]152]164]328]344	32-6300
171-	jkeplnz rkykjke jk/kfd'ku i l ukjke fi = vejk	tkV	163	4-8600
172-	i l ukjke i f vejkjke	tkV	578@222	3-6400
173-	jkeplnz i f tš kjke	tkV	36]37]l Mø] 38]231	13-1400
174-	jkeplnz i f rgyNkjke	tkV	519@341	1-0100
175-	jkeplnz i f ukj; .k	tkV	374@383	13-9000
176-	jkeplnz i f ywkjke	tkV	2	5-9400
177-	jkeplnjke Hkxijke rk: jke l j tkjke i f x.k plš[kkjke	tkV	4]227]273 [2 74]275]l M+ d]276]387	38-9800
178-	jkeirki i f mnkjke	rkV	89	11-4500
179-	jkeirki i f yknjke	tkV	29]306]348	32-5700
180-	jkeirki jkešojyky] jkeplnz	tkV	11]117]417] 418]419	12-7700
181-	jkeirki] euhjke] l hrkjke fi- yPNhjke	tkV	251]252]253	10-1200
182-	jkejru i f i Hkjke	tkV	368	4-6600

Ø-I a	dk'rdkj dk uke	tkr	[kl jk l f; k	{ls-Qy
183-	jkeyky vknjke i f x.k nkukjke	tkV	208	5-4100
184-	jkeyky fxj/kkjhyky Mxjyky jøllrjke i f .k rgyNkjke	tkV	3345	12-2500
185-	jkeyky i f Vhdjke	tkV	92]510@92	4-7400
186-	jkek oYn ekym	tkV	304	2-9100
187-	jkeh i fRu Lo- ekvjkje] eekjke] xki kyjke] vtLjke] gtkjhjke] i ešoj	tkV	532@1	2-7400
188-	jkešoj i f [krk] jktk i fRu Mxj] grjkt] l ghjke] eU kjke] fi- Mxj o vejkl xkšolln] fi- x.kškk	tkV	179	13-8000
189-	jkešoj i f uFkk	tkV	432]434	9-2700
190-	jkešoj i f ilukjke	tkV	361	6-1000
191-	jkešoj i f fgerkjke	tkV	366	9-1100
192-	jkešoj i f xkøllnjke	eškoky	536@215	2-9300
193-	fj?knøh i fRu Lo- gek] ukš k] l f[kk] Mxj fi- gek	eškoākh	135	3-4700
194-	fj?knøh i fRu Lo- cškjke jkeyky nūki f cškjke	tkV	316]317]l M+ d]320]l Mē]321	11-5600
195-	: de.kh i fRu Lo- mnkjke] ekykjke] ekxhyky tBkjke fi- mnkjke	tkV	423	5-9300
196-	: deknøh /kei fRu gj thjke	tkV	169	4-3700
197-	: [kek] i fRu Lo- dškjke] Hkøky] ekMkjke mnkjke] l kguyky] l v[kkjke fi = dškjke	tkV	79]80]81	

Ø-I a	dk'rdkj dk uke	tkr	[kl jk l f; k	{ls=Oy
198-	: ?kkjke i f ekMjke	eʃkoá kh	132]133]485	7-0300
199-	jðlrjke dkkjke l fkkjke i f-x.k fy[kekjke	eʃkoky	216]475	11-3300
200-	jðlrjke i f bzkjke	tkV	350	11-1800
201-	jðlrjke i f ekrhjke	l fkkj	72	2-2300
202-	jðlrk i f puuk	ukbZ	67]139]177	14-7800
203-	jðlrkjke i f bzkjke	tkV	412]424	8-5900
204-	yPNhjke i f tš kjke	tkV	347]467	9-0700
205-	yPNhjke gfjjke ga jkt i f-x.k i kkkjke	tkV	436	3-9800
206-	ykNknøh i fRu Lo- ywkjke] ekrhjke] rtkjke] ekgyuky fi- ywkjke	tkV	209]323]430]472	45-7000
207-	yknw i f plnk	uk; d	9	3-0900
208-	ykykjke dkyjke i f-x.k Ql kjke	uk; d	289	8-5500
209-	ykyjke] ekgyjke] ukudjke] mnkjke jktjke] i kjk fdLrjh i f i f=; ka fyNe.kjke	tkV	354	8-4000
210-	ykyjke] ekgyjke] ukudjke] jktjke]mnkjke] i kjk fdLrjh i f i f=; ka fyne.kjke	tkV	32	8-8900
211-	fyNek [krw i f=; ka jðlrh i fRu j fkkjke	eʃkoky	498	4-1200
212-	fyNek /k-i- : ikjke	tkV	531@1	5-8200
213-	fyNeknøh] vkl hj i eh] puh i f; ku	uk; d	312]426	12-4800
214-	fyNeknøh /k-i- puukjke	tkV	14] 504@14	3-1600

Ø-I a	dk'rdkj dk uke	tkr	[kljk l f; k	{ls=Qy
215-	ywkk i ƒ tho.k	tkV	60]61]62]l Me]65	11-0100
216-	ywkkjke mnkjke i ƒ x.k tho.kjke	tkV	298]425	27-4700
217-	ywkjke i ƒ xækjke	tkV	295	7-9000
218-	ywkkjke i ƒ iwkkjke	eskoákh	238]405	11-8500
219-	ywkkjke oYn fy[kekjke	tkV	278]279]l M+ d]283	3-9400
220-	'kadjyky ckcwyky eukst dækj fi-mnkjke	tkV	373	5-0600
221-	'kadjyky] jkepUn] y{e.k] Hkjrdækj l w l d k'k i ƒ x.k : i kjke	tkV	371]372	16-8200
222-	'kkfUrnøh /k-i- l UrkSkdækj	tkV	543@486	3-85500
223-	'kkfUrnøh /kei fRu i Hkjke	tkV	332	4-9600
224-	'kkfUrnøh ½dækj h½ i ƒ h jkeyky	tkV	378	0-5800
225-	f'koukFkjke] gMekuljkedj.k fi- x.kSkkjke	tkV	357]359	9-8000
226-	'kjk i ƒ xkdkw	uk; d	210	2-7000
227-	'kjkjke i ƒ xkskjke	uk; d	514@314]5 15@482	7-0200
228-	'kjkjke i ƒ e?kkjke	tkV	21]267]268] 269]393	21-7100
229-	'kjkjke i ƒ fyNe.kjke	uk; d	34	8-2300
230-	Jo.kjke i ƒ nykjke	tkV	362	13-9100
231-	Jo.kjke i ƒ jrukjke	y[kkjk	99]157]158] 473	25-2700

Ø-I a	dk'rdkj dk uke	tkr	[kljk l f; k	{ls-Qy
232-	Jhjde i f xakjde	tkV	161	4-5500
233-	Jhjde i f Hkhkjke	tkV	25]86]141	9-7200
234-	Jhjde i f ekMw	tkV	254	4-5400
235-	eghjke i f xkøljke	eškoky	542@440	2-8200
236-	I ghjeljkeyky] jkeirki] jølrjke i f x.k ij [kkjke	tkV	170	6-5500
237-	I ktujke i f ukfkjke	eškodkh	404	8-3500
238-	I hrkjke i f tkkkjke	tkV	68]449	5-3900
239-	I fkk i f gek	eškodkh	206	5-6900
240-	I [kkjke røNkjke rkyjke jølrjke jkeyky] i f x.k tš kjke nknk pøkjke	tkV	154]døkk]15 5]296]496	25-4100
241-	I [kkjke i f tš k	tkV	266	1-8700
242-	I [kkjke i f tš kjke	tkV	22]186]309] 394	14-5600
243-	I [kkjke i f tkkkjke	tkV	450	5-4000
244-	I [kkjke i f ekykjke	tkV	3	7-4600
245-	I [kkjke i f jkÅjke	yøkj	522@494	2-4500
246-	I [kkjke i f gekjke	tkV	124]431	9-9700
247-	I øuk i f Ru Lo- cøkk pkfkjke Jo.kjke j[kkjke fi- cøkkjke	uk; d	288	6-6500
248-	I øuknoh /kei f Ru fxj/kkjhyky vkøi d'k] k] 'køjyky] ujskøøk] egkohj i] kn] f'kojru	cä.k	333	4-9100

Ø-I a	dk'rdkj dk uke	tkr	[kl jk l f; k	{ls-Qy
249-	I quh i fRu Lo- fd'kuk] Mpkj i f fd'kuk	l ka h	271	1-9500
250-	I kuhnoh i fRu Lo- vknjke gækjke Hkkxjke jktjke dkyjke l kojye i f-x.k vknjke	tkV	12]420	7-9600
251-	I jtkjke i f ykHkjke	tkV	369	7-8800
252-	I kuhnoh i fRu Lo- Jhjke ekMjke i f Jhjke	tkV	192]509]192	7-9800
253-	I kguyky i f [krkjke	tkV	111]114	9-9700
254-	gMeku [kkyk; r i f ehjka	ckā.k	19]299	10-2600
255-	gjth i f tš k	tkV	98	5-0600
256-	gfjjke chtwrw/Nh i f i f=; ka cskjke] /kuhnoh i fRu Lo- cskjke	eškod kh	185]197	16-4600
257-	prjkjke] rk: jke] ghjkjke] Hkj kjke] tšk kjke] chjcyjke fi- tsukjke	eškod kh	599@185]6 01@197	8-0500
258-	ghjk i f fy [kek	tkV	39]40] l Me]41	1-2000
259-	ghjknoh i fRu Lo- yknjke dšyk'k pln] vkei d'k x.k kjke] l hrk /kuh ykyh ekyh i f i f=; ka yknjke	ukbz	84	12-5700
260-	geki f yknw	eškod kh	245	6-5000
261-	xke l ekt }kjk pjkbz ; k vl; iz kst u ds fy, j [kh xbz , oafcuk cbz xbz Hkfe xkpj		256]257]258]294	20-5600
262-	Mkyh einj Jht l ukth egjkt		184	13-4200
263-	jkt dh; foHkx vFkok l kožtfud l ħFkkvka dh Hkfe&fo ky; Hkoxu , oa [ky einu		292	2-0200

Detail of Project

5. Name of Project : Bikaner (IWMP) 28
6. Sanction No. & date of Project :
7. Macro & Micros Nos :
8. Deviation from Project Sanctioned :

Items	As per Project Sanctioned	As proposed in DPR
Project Area		
Macro/Micro No.		
Name of Gram Panchayats		
Name of Villages		
Project Cost (Rs. in Lakhs)		

CERTIFICATE

Certified that the undersigned have proposed the appropriate and need based activities required in the watershed project area with active participation of beneficiaries along with consultation of Watershed Committees (WCs). Approval of watershed project plan and DPR as been obtained from WC, Gram Sabha. The plan and DPR document of IWMP project, at P.S. District is technically sound, viable and appropriate for implementation during the period 20.....- 20.....

We recommended tat this plan be sanctioned and put to implementation.

Signature	Signature	Signature	Signature	Signature	Signature
Chairman	Secretary	WDT member	Junior Engineer P.S.....	Assistant Enginner & PIA P.S.....	Project Manager, WCDC Dist.....

Base Line Survey Format for IWMP MIS Website

Project Name

Total Geographical Area of Project (Lakh Hectares)

Wasteland (Lakh Hectars)		Rainfed Agricultural Land (Lakh Hectares)	
Total Cropped Area (Lakh Hectars)		Net Sown Area (Lakh Hactares)	
Total no of Water Storage Structure		Total no. of water Extracting Units	
Total storage capacity of water storage structures (Cubic meters)			

SC		ST	
Others			
Total Population of the project Area		No. of Household of Landless people	
Total no. of BPL Household			
No. of person-days of Seasonal Migration		No. of Marginal Farmer's Household	

Pre-monsoon		Post- monsoon	
No. of person-days of Seasonal Migration			

